

Reports of the Research Committee
of the
Society of Antiquaries of London

No. VII

Second Report on the
Excavation of the Roman
Fort at Richborough, Kent

By J. P. Bushe-Fox, F.S.A.



Oxford

Printed at the University Press by John Johnson for

The Society of Antiquaries

Burlington House, London

1928

Price Seven Shillings and Sixpence

SOCIETY OF ANTIQUARIES

RESEARCH COMMITTEE

THE EARL OF CRAWFORD AND BALCARRES, K.T., LL.D., F.R.S.,
President.

SIR C. HERCULES READ, LL.D., *Hon. Vice-President.*

SIR ARTHUR J. EVANS, M.A., D.LITT., F.R.S., *Hon. Vice-President.*

REGINALD A. SMITH, B.A., *Vice-President.*

W. MINET, *Treasurer.*

CHARLES R. PEERS, C.B.E., M.A., *Director.*

RALPH GRIFFIN, *Secretary.*

HAROLD BRAKSPEAR.

J. P. BUSHE-FOX.

A. W. CLAPHAM.

REV. G. H. ENGLEHEART, M.A.

LT.-COL. WILLIAM HAWLEY.

A. KEILLER.

W. G. KLEIN, *Treasurer of the Richborough Excavation Fund.*

W. H. KNOWLES.

E. THURLOW LEEDS, M.A.

R. S. NEWALL.

WILLIAM PAGE.

H. J. E. PEAKE, M.A.

T. DAVIES PRYCE, M.R.C.S.

MILL STEPHENSON, B.A.

W. M. TAPP, LL.D.

R. E. MORTIMER WHEELER, D.LITT.

H. S. KINGSFORD, M.A., *Assistant-Secretary.*

CONTENTS

	PAGE
INTRODUCTION	I
SUMMARY OF THE RESULTS	3
DESCRIPTION OF THE EXCAVATIONS	9
The Early Occupation	10
The Great Concrete Platform	10
The Marble Casing	12
The First House on Site III	13
The Second House on Site III	15
The Defensive Ditches within the Fort	18
The Foundation of a Fort Wall in Site III	22
The Bath Building, Site III	24
Other Buildings within the Fort	25
The Pits	27
The Chapel of St. Augustine	34
SMALL OBJECTS IN METAL, BONE, ETC.	40
THE POTTERY—	
The Decorated Samian	53
Potters' Stamps	61
Stamps on Decorated Samian	62
Stamps on Plain Samian	72
Stamps on Imitation Samian (Late Red-coated ware)	92
Stamp on Lamp	92
Stamps on Amphorae	93
Stamps on Mortaria (pelves)	94
Graffiti	96
Lamps	97
The Coarse Ware	97
THE COINS—	
Coins from the Surface Clearing	106
i. The Roman Evacuation	110
ii. Mints of the House of Valentician I	113
iii. Mints of the House of Theodosius	114
Coins found in the Summer Excavations, 1924-5	118

LIST OF ABBREVIATIONS

<i>Album Caranda</i>	Moreau, <i>Collection Caranda aux époques pré-historique, Gauloise, Romaine et Franque.</i>
<i>Altertümer uns. heid. Vorzeit</i>	<i>Altertümer unserer heidnischen Vorzeit.</i>
<i>Antiq. Fourn.</i>	<i>The Antiquaries' Journal.</i>
<i>Arch.</i>	<i>Archaeologia.</i>
<i>Arch. Ael.</i>	<i>Archaeologia Aeliana.</i>
<i>Arch. Cant.</i>	<i>Archaeologia Cantiana.</i>
<i>Arch. Fourn.</i>	<i>The Archaeological Journal.</i>
<i>Ashley Rails</i>	Sumner, <i>A descriptive account of the Roman pottery made at Ashley Rails, New Forest.</i>
Atkinson, <i>Pompeii</i>	Atkinson, <i>A hoard of Samian ware found at Pompeii</i> , in <i>J.R.S.</i> IV, 27.
<i>B.M.C.</i>	Keary, <i>A catalogue of English Coins in the British Museum. Anglo-Saxon series.</i>
Behn, <i>Römische Keramik Bonn. Jahrb.</i>	Behn, <i>Römische Keramik mit Einschluss der hellenistischen Vorstufen.</i>
Bulliot, <i>Mont-Beuvray</i>	Bulliot, <i>Fouilles de Mont-Beuvray de 1867-95.</i>
<i>C.I.L.</i>	<i>Corpus Inscriptionum Latinarum.</i>
<i>Chester Arch. Soc. Fourn.</i>	<i>Journal of the Chester and North Wales Archaeological Society.</i>
Cohen	Cohen, <i>Description historique des monnaies frappées sous l'Empire Romain.</i>
<i>Coll. Antiq.</i>	Roach Smith, <i>Collectanea Antiqua.</i>
<i>Corbridge</i>	} Reports on the excavations at Corstopitum published in <i>Archaeologia Aeliana.</i>
<i>Corbridge Report</i>	
<i>Déch.</i>	Déchelette, <i>Les vases céramiques ornés de la Gaule Romaine.</i>
Déchelette, <i>Manuel</i>	Déchelette, <i>Manuel d'archéologie préhistorique, Celtique et Gallo-Romaine.</i>
Drag.	Dragendorff, <i>Terra Sigillata</i> in <i>Bonn. Jahrb.</i> , vols. 96-7, 99.
<i>Eph. Epigr.</i>	<i>Ephemeris Epigraphica.</i>
Evans	Evans, <i>The Coins of the Ancient Britons.</i>
Fölzer	Fölzer, <i>Die Bilderschüsseln der ostgallischen Sigillata-Manufakturen.</i>
Forrer	Forrer, <i>Die römischen Terra-Sigillata Töpfereien von Heiligenberg-Dinsheim und Iitenweiler im Elsass.</i>
<i>Glast. Lake Vill.</i>	Bulleid & Gray, <i>The Glastonbury Lake Village.</i>
Grueber, <i>B.M.C.</i>	Grueber, <i>Coins of the Roman Republic in the British Museum.</i>
Haltern	Loeschcke, <i>Die keramischen Funde in Haltern</i> , in <i>Mitteilungen der Altertums-Kommission für Westfalen</i> , v.
<i>Hedd. Mitth.</i>	<i>Heddernheimer Mittheilungen.</i>

- Hengistbury Head Report* Bushe-Fox, *Report on Excavations at Hengistbury Head*. Reports of the Research Committee of the Society of Antiquaries, III.
- Jacobi
F.R.S.
Kenchester Jacobi, *Das Römerkastell Saalburg*.
The Journal of Roman Studies.
- Knorr, B. und E. Jack & Hayter, *Excavations on the site of the Romano-British Town of Magna, Kenchester*, published by the Woolhope Naturalists' Field Club.
- Knorr, Cannstatt Knorr & Sprater, *Die westpfälzischen Sigillata-Töpfereien von Blickweiler und Eschweiler Hof*.
- Knorr, Rottenburg Knorr, *Die verzierten Terra-Sigillata-Gefäße von Cannstatt und Köngen-Grinario*.
- Knorr, Rottweil Knorr, *Die verzierten Terra-Sigillata-Gefäße von Rottenburg-Sumelocenna*.
- Knorr, 1912 Knorr, *Die verzierten Terra-Sigillata-Gefäße von Rottweil* (1912).
- Knorr, 1919 Knorr, *Töpfer und Fabriken verzierter Terra-Sigillata des Ersten Jahrhunderts* (1919).
- Knorr, 1921 Knorr, *Kastell Cannstatt: neugefundene Terra-Sigillata-Gefäße* (1921).
- Lamprecht Lamprecht, *Aufdeckung eines römischen Friedhofes zu Regensburg*.
- Lud. { Ludowici, i. *Stempel-Namen römischer Töpfer von meinen Ausgrabungen in Rheinzabern*;
Lud. *Rheinz.* { ii. *Stempel-Bilder*; iii. *Urnen-Gräber*;
- M. & S. Mattingly & Sydenham, *The Roman Imperial Coinage*.
- May, *Silchester* May, *The Roman pottery found at Silchester*.
- May, *Templebrough* May, *The Roman Forts of Templebrough near Rotherham*.
- May, *York* } May, *The Roman Pottery in York Museum*.
- May, *York Pottery* }
- Meunier Meunier, *L'établissement céramique de Lavoye*, in *Bulletin archéologique du Comité des travaux historiques et scientifiques*.
- Miller, *Balmuildy* Miller, *The Roman Fort at Balmuildy (Summerton, near Glasgow) on the Antonine Wall*.
- Nass. Ann.* *Nassauische Annalen*.
- Newstead* } Curle, *A Roman Frontier Post. The Fort at Newstead*.
- Curle, *Newstead* }
- Num. Chron.* *The Numismatic Chronicle*.
- O. & P. } Oswald & Pryce, *An introduction to the study of Terra-Sigillata*.
- Oswald & Pryce }
O.R.L. *Der Obergermanisch-Raetische Limes des Römerreiches*.
- Oelmann Oelmann, *Die Keramik des Kastells Niederbieber*.

- Proc. Soc. Ant.* *Proceedings of the Society of Antiquaries.*
Proc. Soc. Ant. Scot. *Proceedings of the Society of Antiquaries of Scotland.*
- Reubel Reubel, *Römische Töpfer in Rheinzabern.*
Richborough, I Bushe-Fox, *First Report on the excavation of the Roman Fort at Richborough.* Reports of the Research Committee of the Society of Antiquaries, VI.
- Ritterling } Ritterling, *Das frühromische Lager bei Hofheim,*
 Ritterling, *Hofheim* } *in Nassauische Annalen*, XXXIV, XL.
S.P. Dom. } *State Papers, Domestic.*
 Sabatier Sabatier, *Géographie numismatique: monnaies impériales romaines* in *Revue de la numismatique belge*, sér. 4, tome 5.
- Sloden & Black* Sumner, *A descriptive account of Roman pottery sites at Sloden and Black Heath Meadow, Linwood, New Forest.*
Heath Meadow
- Sussex Arch. Coll.* *Sussex Archaeological Collections.*
Swarling Report Bushe-Fox, *Report on the excavation of the Late-Celtic Urn-field at Swarling, Kent.* Reports of the Research Committee of the Society of Antiquaries, v.
- Texeira* Texeira de Aragão, *Descrição Geral e Historica das Moedas cunhadas em nome dos Reis, Regentes e governadores de Portugal.*
- Trans. Cumb. & Westm. Ant. & Arch. Soc.* *Transactions of the Cumberland and Westmorland Antiquarian and Archaeological Society.*
V.C.H. *The Victoria History of the Counties of England.*
Val. Eccl. *Valor Ecclesiasticus.*
- Walters } Walters, *Catalogue of Roman Pottery in the*
 Walters, B.M. Cat. } *British Museum.*
 Walters, *Lamps* Walters, *Catalogue of Roman Lamps in the British Museum.*
- Webb Webb, *The reign and coinage of Carausius.*
 Wheeler, *Brecon* Wheeler, *The Roman Fort near Brecon*, with a section on the Terra-Sigillata or Samian ware, by T. Davies Pryce and Felix Oswald.
- Wheeler, *Segontium* Wheeler, *Segontium and the Roman occupation of Wales*, in *Y Cymmrodor*, 33.
- Woolhope F.C.* Woolhope Naturalists' Field Club.
Wroxeter Bushe-Fox, *Excavations on the site of the Roman Town at Wroxeter, Shropshire, in 1912, 1913, 1914.* Reports of the Research Committee of the Society of Antiquaries, I, II, and IV.

I followed by a [numeral]. In the coin list refers to the coin of that number in the first Richborough Report.

Excavations at Richborough, Kent

(Second Report)

By J. P. BUSHE-FOX, F.S.A.

INTRODUCTION

THE selection of a site for the excavations in the summer of 1924 was influenced by the fact that in the early months of that year the Office of Works had begun the systematic clearing of the top soil from the area within the walls of the fort. The most convenient method for the removal of this surface soil was to start in the north-east angle of the fort and work westwards and southwards, the soil being tipped over the slight cliff to the east and into the field north of the fort. This surface clearing resulted in a considerable area being lowered by some three feet, and the tops of several walls were disclosed in the course of the work.

No effort was made to trace these walls at the time, and the greatest care was taken not to interfere with any structure or with remains of any description that appeared to be *in situ*, nothing but the mixed top soil being removed. As the removal of this soil greatly facilitated excavation, work was not continued by the Society in the neighbourhood of site I, which had been explored in 1922-3, but a start was made in the north-east angle of the fort with the intention of following the surface-clearing operations of the Office of Works. This surface clearing was continued in the summer of 1924 and in the following winter, with the result that some two-thirds of the site was dealt with, as can be seen in the air photograph (pl. II).

Even after the removal of the surface soil had been completed a great depth still remained to be explored; also the remains of the buildings met with were found to be of a very complicated nature, and in consequence the progress of the Society's excavations was slow. In 1924 the greater part of the buildings on site III and also the Chapel site were cleared, but much time had to be spent in completing their investigation in the summer of 1925. In the latter season more ground was also opened out to the south and west of site III and to the south of the Chapel, resulting in several interesting discoveries, including a system of three parallel defensive ditches in connexion with which more work was done in the vicinity of site I.

2 REPORTS OF THE SOCIETY OF ANTIQUARIES

The clearing of the top soil by the Office of Works in the early part of 1924 and in the winter of 1924-5 was done by a gang of some forty to sixty unemployed under the supervision of Mr. W. G. Klein, F.S.A. Mr. Klein also assisted in the supervision of the work for the whole period each summer. Mr. Thomas May, F.S.A., dealt with the very large accumulation of pottery found during the surface clearing and was present on the site each summer, the inventory of the pottery and the drawings of the coarse ware being done by him. Mr. Davies Pryce, F.S.A., is responsible for the description of the decorated Samian and Mr. C. A. R. Radford for the majority of the notes on the small objects. The following have taken part in the excavations and given much assistance in various ways :—Mr. Mill Stephenson, F.S.A., Mr. and Mrs. Clauson, Mr. and Mrs. Hodges, Mr. and Mrs. Jervoise, Mr. O. F. Parker, F.S.A., Mr. W. P. D. Stebbing, F.S.A., Miss Gill, Miss Hayter, Miss Hobling, Miss Standen, and Miss Trevelyan. The plans are the work of the architectural staff of H.M. Office of Works.

The cleaning, identifying, and listing of the 15,365 coins found in the surface clearing has been a work of the greatest magnitude, the majority being in very poor condition and difficult to decipher. The Department of Coins and Medals at the British Museum undertook this task, which was, however, entrusted to Mr. F. S. Salisbury, to whom every facility and assistance were afforded. The list printed in this report has been compiled by him. The identifying and listing of the post-Roman coins are the work of Mr. G. C. Brooke.

The coins found during the excavations in the summers of 1924 and 1925 have been dealt with by Mr. J. W. E. Pearce who was assisted by Mr. A. G. K. Hayter and Mr. Stebbing.

The elucidation of the fragmentary remains of the Chapel is largely due to Mr. A. W. Clapham, F.S.A.

The death of Mr. A. G. K. Hayter, F.S.A., occurred while the preparation of this report was in progress. His loss cannot be over-estimated as he has been intimately connected with the research work of this Society for many years and has contributed most valuable sections on potters' stamps and coins to several of the reports. He also took an active part in the actual excavations on many occasions, his experience and knowledge adding greatly to their success. Before he was taken ill he had already compiled part of the list of potters' stamps appearing in this report ; its completion is due to his son, Mr. G. C. F. Hayter, who has been associated with the excavations at Richborough since they began in 1922.

SUMMARY OF THE RESULTS

The deductions drawn from the evidence obtained in the 1922-3 excavations and previous discoveries on the site, which were set forth in the last report, have in the main been confirmed and in some instances amplified by the work that has since been done.

A Claudian occupation has now been definitely established, but not its extent or character. The finds for this period were perhaps not so abundant as in the previous excavations, and it is possible that the main early settlement or camp may lie more to the south or west. No masonry buildings of this period have as yet been met with, but further evidence of wooden or half-timber houses has been noticed at the lowest levels. A carefully constructed well that had fallen into disuse and been filled in by the middle of the first century contained toilet articles and evidence of weaving, which suggest that there was some form of domestic occupation even at that early period. The coarse-ware vessels found in the early deposits are exactly similar in style and technique to those in use in this district before the invasion, a point which clearly indicates that the natives were either supplying goods to the Romans or, what is more probable, had been forced to work for them.

Although there is still much to learn about the early history of the site, there can be little doubt that, as far as the area under review is concerned, a great increase in the population took place towards the close of the first century. It is now also reasonably certain that the building of the marble-cased structure with its huge concrete foundation took place in the period between A. D. 80 and 120.

Practically the whole area examined in the summers of 1924-5 bore evidence of this undertaking, as at a low level—but always overlying the remains of earlier occupation—were piles of masons' chippings of Oolite, Lower Greensand, etc., blocks of chalk and travertine, and quantities of flints. In the vicinity of the great foundation was an uneven layer of mortar spread over a considerable area and varying in thickness from a hardly discernible deposit to six or eight inches. The mortar was similar to that used in the structure itself, and this layer can only represent the residue left on the mixing floor when the building operations were in progress. Fragments of the marble casing also first make their appearance in the strata of this period, while among the hundreds of pieces from the higher levels were several small portions of a large inscription (pl. XIII). Unfortunately insufficient of this has

4 REPORTS OF THE SOCIETY OF ANTIQUARIES

as yet been found to make a reading possible, but the lettering is of a type in vogue about A. D. 100 and therefore affords an additional piece of evidence for the date of the building. The first masonry house on site III also belongs to this period, and it is more than possible that it served as the home of the officer in charge of the building operations, as although of ample proportions it was not constructed with the usual solidity of Roman work of that date and the walls of plastered loamy clay suggest a building rather for temporary than permanent use. In any case the life of the house was not a long one, and after it was levelled to its foundations another was built upon the same site. There is no definite evidence for the date of this second house, but its construction is very similar to the main building on site I assigned to the first half of the second century, and there can be little doubt that it belongs to approximately the same period.

As was noticed in the previous excavations, the occupation of the site although continuous was not of such an intensive nature from the first quarter of the second century until the middle of the third. It was suggested in the first report that the falling off in finds for this period might be connected with a change from an intensive occupation by artisans employed on the building of the great marble-cased structure to one of a more domestic character. There is also the possibility that Richborough may have lost some of its importance after the building of Hadrian's wall, and even more so during the period when the Antonine wall was held in Scotland, as much of the trade passing through this and other southern ports in the early days, when the northern districts were still in a state of unrest, may later have been carried farther up the east coast in order to save long-distance transport by land.

At some date in the third century that has yet to be accurately determined a great change came over the site. The peace and security of this commercial settlement were threatened and it was found necessary to construct a camp or fort with three defensive ditches and probably an earthen mound and stockade. These defences enclosed the great concrete foundation, but there is some evidence that the marble-cased superstructure was by then in ruins, if indeed it had not already been levelled, but whether this was the case or not, there is no reason to suppose that its inclusion within the area of the fort either for its preservation or for tactical reasons was intentional. That this particular spot should have been selected is undoubtedly due to the fact that it was the highest ground near the edge of the cliff and therefore the best position for a defensive work. It also had the additional advantage of being easily accessible by an existing road.

Up to the present little more has been done than to trace the line of the ditches of this fort on the north side of the main east-and-west road. In doing this, however, some interesting information was obtained as the ditches were found to cut through the western part of the building on site I. It is impossible to say whether or no this house was intentionally levelled by the builders of the fort, but it is difficult to believe that it was by then deserted and in ruins unless destroyed in some Saxon raid—a not improbable contingency—which may have been the primary reason for the construction of this defensive work.

If the house on site I had been deliberately destroyed by the builders of the fort their treatment of the one on site III was entirely different, as the two outer ditches terminated a few feet from its west wall while the line of the inner was arranged so as just to miss the south-west angle. That this house should have been respected is a most curious feature and one for which there appears to be no reasonable explanation, as its presence at this point would have been a source of great weakness and very detrimental to the defences.

The ditches had been dug in mixed soil containing the debris of some two hundred years of occupation, and the greater part of the soil removed from them was in all probability again replaced when they were filled in and the rampart levelled. Also after this had been done the site was heavily occupied for a hundred to a hundred and fifty years, which resulted in later objects being introduced into the filling. To obtain the precise date when they were dug or filled in is therefore extremely difficult, but it is hoped that this may be ascertained by further excavation. At present the indications point to the fort having been built well in the third century—possibly rather after than before A.D. 250—and the absence of any considerable deposit of silt in the bottom of the ditches suggests that they were not open for any great length of time. Several reasons suggest themselves for the construction of a fort here in the third century, such as a defence against Saxon raids, a stronghold for a detachment of the forces of Carausius or Allectus, or a temporary protection for the builders of the main Saxon Shore fort, but to attempt to arrive at any conclusion at this stage of the excavations is obviously premature.

A general levelling of the site must have taken place when the Saxon Shore fort was built, the walls of which still stand to a considerable height, and it was probably then that the three ditches of the earlier fort were filled in and the house on site III levelled. The remains of some of the walls of this house actually underlie the north wall of the Saxon Shore fort.

6 REPORTS OF THE SOCIETY OF ANTIQUARIES

A puzzling feature which must also belong to this stage in the history of the site is a foundation 13 ft. wide laid on a line nearly at right angles to the north wall of the fort and cutting through the remains of the house on site III as well as the inner ditch of the earlier fort to the south. In character it was very similar to the foundation of the walls of the Saxon Shore fort and it can only have been constructed to carry a defensive wall of similar type. Unfortunately both ends of this foundation were broken away by the erosion of the site, and as all trace of the north wall of the Saxon Shore fort had also disappeared at what would have been the point of junction between the two, there was no means of ascertaining whether they were the same build. The first assumption was that the east wall of the fort, the remains of which lie in a tumbled heap on the marsh below, had stood on this foundation, but this could hardly have been possible as the latter was too far back from the edge of the cliff. There is also another serious objection to this as the north-east angle of the fort would then have been unreasonably close to the rectangular turret on the north wall. It should be noticed that other existing turrets were placed in each instance midway between an angle and an entrance. Had this one been similarly spaced the north-east angle of the fort would have been considerably farther to the east, as it may well have been, the high ground undoubtedly extending much farther in that direction in Roman times than it does now. If, then, this foundation does not coincide with what was apparently the finished plan of the fort, the only possible reasons for its presence are, either that after it was laid down there was a change of plan, the wall being built farther to the east, or the original east wall, having been placed too near the edge of the cliff, collapsed, and this foundation for a new line of defence was formed on more stable ground to the west. A certain amount of light is thrown upon the problem by the discovery of some 140 coins in a deep shaft sunk through this foundation. Many of these coins were in such poor condition that they could not be ascribed to any particular emperor, but none was apparently later than the latter part of the third century and it is therefore obvious that the foundation must have been in existence at that time and that no wall was then standing on it. As a matter of fact there was no evidence that a wall was ever built upon it, and as it is also impossible to conceive that this side was left undefended from the end of the third century onwards, the most likely explanation is a change of plan in the lay-out of the fort, which in the first instance was apparently intended to be approximately square, as were Porchester, Alzei, and other late examples.

Incorporated in the ruins of the second house on site III was a small bath building belonging to the period of the fort. It consisted of a vestibule or dressing-room with a cold bath on the north side and on the west a warm room through which the hot or sweating room could be entered. This type of small bath building is not uncommon, and at Richborough may well have been used by the officers of the garrison. It was not well built, and for this reason and also because it remained in use for a lengthy period there was much evidence of alterations and rebuilding. The discovery of a coin of the Emperor Tetricus under the floor of the dressing-room indicates that this building was not erected before the latter part of the third century. There is no reason to suppose that it did not continue in use until the final evacuation of the fort.

It is surprising, now that the top three feet of the soil has been removed from upwards of two-thirds of the area within the walls, that no other masonry buildings of the fort period have been met with. That there existed habitations within the fort is quite certain, and ample evidence of the intensive nature of the occupation is supplied by the large number of late coins and fragments of pottery of the same period. All the top soil was much darkened, and patches of burnt matter, often intermixed with pieces of burnt clay, some showing the impression of wattle, were frequently encountered. Here and there were hearths generally composed of tiles, while extremely irregular layers of pebbles, stones, broken tiles, etc., varying from nearly a foot to less than an inch thick, occurred in a most indiscriminate and practically unplannable fashion. More work has yet to be done upon these scanty remains, but it can hardly be hoped that much information will be derived from them, as they appear to represent a series of irregularly placed structures of wood or wattle and daub with thatched or tiled roofs. There were some indications that the floors were occasionally of mortar, layers of small pebbles, or sand, but it is more likely that they were usually of wood or simply trodden earth. Outside these buildings were cobbled paths and yards. If, as seems probable, this was indeed the nature and lay-out of the buildings, the interior must have presented a striking contrast to that of the forts of an earlier period with their well-built praetoria surrounded by barracks, granaries, etc., in orderly array. Such a state of affairs must also indicate a great falling off in the thoroughness and efficiency of the Roman military organization, especially as this fort was not garrisoned by a small and unimportant detachment but by the Second Legion itself.

It is disappointing that even now, after such a large number of coins has been found and identified, the date of the final abandon-

ment by the Romans cannot be accurately fixed. That there should be this uncertainty is mainly due to the cessation of the issue of copper coinage by the western mints a few years before A. D. 400. As a result, practically the only copper coins that could have been available for use in the early fifth century at Richborough would have been those minted in the fourth century, and there would seem to be no sure method of estimating the length of time these may have continued in circulation. It is tempting to infer that the large number of coins of the period A. D. 383 to *c.* 395 must indicate an intensive occupation well into the fifth century, but as at present there is no other corroborating evidence it cannot be accepted as a certainty. Also factors other than a prolonged occupation after the cessation of the mints may have been responsible for this mass of coins. The currency was greatly depreciated, an individual small copper coin was of practically no value, it was easy to lose, difficult to find, and hardly worth looking for if dropped. The population of the site was at times greatly augmented by the passage of troops to the Continent, and civilians were also probably leaving this disturbed country in search of a safer place of abode. At such a time of unrest and uncertainty hoards of coins would be buried for security, and if never recovered would, if broken up and distributed by subsequent agricultural operations, etc., help substantially to account for the number of coins now being found.

The only coins that can be assigned with certainty to the early years of the fifth century are two silver examples of Constantine III, A. D. 407-11.¹ These are not sufficient to affect the argument one way or the other except to prove that the site was occupied up to, at any rate, the time of Constantine III. This is so eminently probable that it is hardly worth proving, as it is extremely unlikely that Constantine III would have left one of his principal Channel ports unguarded while carrying on his campaigns on the Continent. What happened after the end of the first decade of this century is still a matter of conjecture. Although this country was then abandoned to its fate by the Romans and most of the trained troops had probably been taken away by Constantine, it is difficult to believe that the Britons made no effort to continue the defence of such strategically important places as Richborough and other forts of the Saxon Shore. Reasonable as this assumption appears, there is at present no proof for it. There is, however, some evidence that Richborough, with its

¹ It is possible that some of the *Salus Reipublicae* type minted at Rome and Aquileia may have been issued after A. D. 400, and it is thought by some numismatists that certain barbarous copies of late third- and fourth-century coins may prove to be of post-Roman date. The two coins of Carausius II may also belong to the early part of the fifth century.

sheltered harbour, easy to negotiate, from which a road ran direct to Canterbury, continued to be used as a landing-place for travellers and invaders. Coins have been found upon the site during the present excavations and in former times (*Arch. Cant.*, vol. xviii, p. 72; C. R. Smith, *Richborough, Reculver, and Lympne*, p. 157) which form a nearly complete series for the period from the middle of the fifth century to the eleventh or until after the formation of the later port of Sandwich. This series consists of one coin of Leo I 457-74, one of Justinus 518-27, two of Justinianus 527-65, several sceattas sixth to eighth century, four of Offa 757-96, one Eadwald c. 800, one Aethelheard 793-805, one Berhtwulf 839-52, one Ethelred 841-50, and one of Ethelred II 978-1016.

The medieval tradition that Saint Augustine landed here in A.D. 597 may well have been founded on fact. The impression of his foot is said to have been miraculously left upon a stone when he stepped ashore. This stone was kept as a precious relic in a small chapel dedicated to the saint, situated within the walls of the fort. Upon the anniversary of the landing pilgrims flocked there to pray and to recover health. The remains of what is believed to have been this chapel have been uncovered during the recent excavations, and although little of the structure now exists there is sufficient to show that in part it was of twelfth-century date. There were also indications of earlier work, and when it is considered that Saxon coins have been found upon the site it does not seem unreasonable to assume that a church of that period stood within the walls of Richborough as was the case at other forts of the Saxon Shore, viz. Burgh Castle, Othona, Reculver, and Dover.

DESCRIPTION OF THE EXCAVATIONS

The first report issued dealt with the discoveries made up to the autumn of 1923. Since then the top three feet of soil have been removed from the northern portion of the interior of the fort and from the whole of the area immediately surrounding the concrete platform (pl. 11). The main area examined during the two seasons now under review was site III in the north-east angle of the fort. The chapel site has also been entirely dug out and some work done at the lower levels to the east and north of the platform and also in the vicinity of site I.

The whole of site III was covered with a complex of walls and foundations which on examination were found to consist principally of the remains of three houses of different dates. A complete plan of the site is given on pl. xxxix and several sections on pl. xliv.

Separate plans of each house have also been prepared to make their lay-out the more readily intelligible (pls. XL-XLII).

In dealing with these houses it has been thought best to describe them in chronological order in conjunction with other discoveries made during the excavations. The latter are shown on the plans already mentioned or on the general plan, pl. xxxviii, while the chapel plan is given on pl. XLVII.

THE EARLY OCCUPATION

In the first report (p. 6) it was stated that at the lowest levels burnt layers containing charcoal, post-holes, etc., were frequently met with and that in all probability the earliest buildings were wood or half timber. Similar burnt layers, etc., were found in 1924-5, and although they were not so pronounced and little that could be definitely dated came from them, evidence was obtained that this portion of the site had been occupied soon after the Claudian invasion in A. D. 43. This conclusion had already been arrived at in 1922-3, the contents of pit 14 being assigned to within ten years of that date. Another pit, no. 20, cleared out in 1925, has provided very striking confirmation of this early date. This pit, which in the first instance served as a well, is dealt with in detail on p. 28. It contained a number of interesting objects, among which were sixteen coins of the time of Claudius, but none later, and it is certain that this well had fallen into disuse during that emperor's reign or very shortly afterwards. Since the publication of the last report many other objects that could be assigned to the early years of the occupation have been found. These include fragments of decorated Samian such as pl. xxvii, nos. 1, 2, stamps of Claudian or pre-Flavian potters, and a fair quantity of coarse-ware vessels. The total of pre-Flavian coins is 79. The Flavian coins number 52 and there is also much pottery of that period.

THE GREAT CONCRETE PLATFORM

On the northern and eastern sides of the great concrete platform or foundation, and extending from it some sixty to ninety feet, was a layer of mortar or cement. This layer, which was of a whitish colour and contained a certain amount of grit and small pebbles but no crushed brick, had a very irregular surface and varied in thickness from about half an inch to six or eight inches, while in some places it divided into two or more distinct layers separated by sand (pl. XLVI, sec. 14). It came up to the face of the platform on the northern side, but on the eastern, except for a short stretch at the northern end, it stopped abruptly with a straight face a few

feet away, as shown on pl. XL. The impression of wood could still be seen on this face, indicating that the mortar layer had been bounded by a plank. Neither the western nor southern limit of this layer was ascertained.

The character of this mortar and that used in the platform were very similar, and the former can only represent the residue left on the mixing-floor when this structure was being built. Overlying the whole of this floor was a layer of practically clean sand two to three feet thick, the surface of which was on a level with the top of the platform (pl. XLVI, sec. 14). The explanation of this is that the top five feet of the platform projected ten to twelve feet beyond the face of the lower part and the mixing-floor was in use when the latter was being constructed. When the soil had to be removed for laying the projecting top portion this mixing-floor was cut through and the excavated sand spread over it so as to raise the ground-level to coincide with the surface of the platform. The levelling up on this side was made necessary because the original surface sloped considerably from south-west to north-east. There were distinct indications that a layer of Oolite and Lower Greensand chippings had been placed upon the excavated sand so as to consolidate the surface.

Neither the western nor southern limit of these layers of mortar and sand was ascertained, but they extended eastwards under the chapel and northwards to about the line of the inner ditch, which cut through them. Traces of both were noticed at some points slightly beyond the northern side of this ditch, where they merged into a stratum of masons' chippings of Oolite and Lower Greensand, blocks of travertine and chalk, piles of flints, etc. (pl. XLVI, sec. 14 and pl. XL). On the west of site III and to the north of the later outer ditch this stratum was so solidly packed as almost to suggest road metalling.

It seems obvious that we have here an accumulation of debris deposited when the structure which stood upon the platform was built, and that a general levelling up of the site had taken place when this work was completed. A cut was made through the whole of these strata on the north side of the platform (pl. XLVI, sec. 14) and some useful information concerning their date obtained. Under the mortar layer were two coins of Vespasian, twelve fragments of form 29, A. D. *c.* 60-80, two of 37, A. D. 70-80 and 75-100, one of 18, and a small portion of a green glazed decorated bowl. In the stones was a fragment of form 18 and a piece of marble casing. In the sand above the mortar layer were a coin of Vespasian and two fragments of form 37, A. D. 75-90 and 90-120. It will be seen that these finds point to the building operations and the levelling

up of the site having taken place about the close of the first century A.D. The Flavian date of the upper part of the filling of pit 20, sealed by the mortar layer, affords confirmation of this dating (p. 28). A coin issued in the time of Caligula, A.D. 37-41, was found embedded in the mortar layer near the edge of the later inner ditch south of site III.

It should be noted how closely this dating agrees with that given in the last report (p. 6), where it was suggested that the concrete platform and the marble-cased building which it carried were constructed *c.* A.D. 100.

THE MARBLE CASING

Very little of the marble casing was found at the lower levels in the 1924-5 excavations, and no useful information concerning the date of its introduction on to the site was forthcoming. How long the building that this casing adorned remained standing has yet to be accurately determined, but the fact that upwards of ninety pieces were recovered from the filling of the three ditches, although only small sections of these were cleared, is striking evidence that the structure was in ruins by the second half of the third century.

Among the large number of fragments found in clearing the top three feet of soil were several portions of a large inscription. The letters are $3\frac{1}{4}$ in. high, well cut, and of a type used in the late first and early second centuries, thus corroborating the conclusion derived from other sources that the date of the building was *c.* A.D. 100. The fragments of the inscription are illustrated on pl. XIII. No. 1 reads VM; no. 2, an upright and a portion of a P, B, or R; no. 3, M; no. 4 shows portions of two lines with an A in the upper and M↗ in the lower; no. 5, PE; and no. 6, an upright and SV. The last appears to have formed part of the final line of the inscription.

On the same plate will be seen parts of two numbers, no. 7, /XIII and no. 8 /XX, while another not illustrated reads LXIV or LXIX. No. 9 is on the back of a moulded fragment and is part of two lines of an inscription which could be read either way up. No. 10, T cut on a rough slab of marble and probably a trial piece. No. 11, AVTI ligatured, must be the same fragment as was found in Mr. Garstang's excavations in 1900 (*Arch. Cant.* xxiv, 272); it is published in *Eph. Epigr.* x, 990, where it is described as being in the Canterbury Museum. It was found in the top soil in the winter of 1924-5.

The only remains of figure sculpture in marble were a portion

of a Harpy and the upper part of a colossal human head apparently wearing a cap and with flowing hair on the forehead.

Parts of two draught-boards on slabs of marble casing are illustrated on pl. xiv, fig. 1. No. 1 is very roughly cut, but no. 2 is an elaborate and well-executed example with one complete side of eight squares. No. 3 is not on marble, but on a slab of Lower Greensand.

THE FIRST HOUSE ON SITE III

The earliest masonry building on site III had been practically levelled to its foundations. In some places even these had disappeared, while in others they were covered by the remains of the later houses, which prevented their complete exploration. A plan of the building as far as it could be recovered is given on pl. xl, but originally it must have been of much greater extent, the eastern and most of the northern side having been destroyed by erosion of the site. The full length of the western side was probably ascertained, there being no trace of its continuing farther to the north than indicated on the plan, but a cart-track passing down the slope from the high land to the marsh at this point prevented definite proof being obtained.

It will be seen that the rooms, 1, 2, 4, 7, 8, faced west, 15, 16, 19 south, while 14 was at the south-west angle. No. 13 may have been a passage or stair. No. 11 contained a hypocaust, the stokehole being in 12. With so little remaining, it is impossible to reconstruct the building or to ascertain the method adopted for lighting some of the rooms. No. 17 was probably an open courtyard and no. 9 may also have been open to enable nos. 5 and 10 to obtain light through windows in their south and west walls respectively.

The foundations varied from 1 ft. 10 in. to 3 ft. wide and from a few inches to 2 ft. deep. They were mostly composed of fair-sized flints from the gravel-beds with occasional blocks of chalk, Lower Greensand, Oolite, and a few waterworn pebbles. A portion of the south wall of 15 (pl. v, fig. 1 A) stood several courses high, built up in chalk and gravel-bed flints set in poor coarse mortar, but only the face remained, the rest having been destroyed when the later house was constructed. The western range was the best preserved portion, as the later buildings did not extend over it (pl. III, fig. 2 A) and here the foundations of the outer wall were 2 ft. 6 in. to 3 ft. wide and 2 ft. deep, while those of the dividing walls between the rooms were in most instances only one or two courses deep and 1 ft. 10 in. wide. Portions of the actual walls were still *in situ* on the west of room 4 and between 8 and 13. The latter stood 2 ft. high and

1 ft. 10 in. wide and was built of blocks of stone and flints set very irregularly in clayey loam with two layers of white painted plaster on both faces. The portion on the west wall of 4 was 1 ft. 8 in. high, entirely composed of light clay coated with similar painted plaster. These poorly-constructed walls could not have carried any considerable weight, and it is therefore improbable that an upper story existed over this wing. Rooms 14, 15, and 16 had on their north side a very narrow wall standing on the extreme edge of a foundation more than twice its width, while on their south side were two parallel foundations in close proximity. A rebuilding of this portion of the house may possibly be the explanation of these curious features.

The external walls of the hypocaust, no. 11, and the dividing wall between it and no. 10 stood some 3 ft. high and 1 ft. 10 in. wide (pl. iv, fig. 2 A). They were built up of flints, chalk-blocks, etc., set in clayey loam, the internal face being mostly composed of travertine coated with a hard pink plaster. The floor was of opus signinum, on which were the remains of several brick pilae standing two or three courses high, and it would seem that there were originally four rows of these north and south and five east and west. The bottom tile of one of the flues running up the walls was found in position in the west wall 3 ft. above the hypocaust floor. Embedded in the wall at the south-west angle at the same level as the flue tile was a thin sheet of lead covered with mortar and moulded to form a shallow gully. A lead pipe, evidently for the waste water from a bath above the hypocaust, connected with this and passed through the wall, terminating in a curved tile embedded in the west wall of no. 12. A channel composed of these curved tiles probably originally continued to the outside of the building. No. 12, although only measuring 8 ft. by 3 ft. 10 in., must have been the stokehole. It was entered by a curved step at the west end and at 1 ft. 3 in. from its eastern wall were the remains of two brick piers projecting 11 in. from the north and south walls. These piers had carried a low arch with an opening 2 ft. wide, thus forming a small recess or cupboard at this end of the stokehole in which fuel may possibly have been kept. The floor of the stokehole was of opus signinum and the interior face of the walls and the step were coated with pink plaster. The dividing wall between it and the hypocaust was 1 ft. 6 in. wide, composed of chalk blocks, etc., set in a light brown mortar with little grit or stones, while the opening had brick piers showing signs of heavy burning which must originally have carried an arched head. The floor between these piers had been destroyed by the extreme heat and patched with tiles which rested on a layer of heavily burnt matter.

The clearing of the hypocaust was a difficult operation and was only accomplished by tunnelling, wooden props having to be inserted as the earth was removed to carry the remains of the later buildings which existed above. The floor was covered with burnt matter and the bottom 18 in. of the filling consisted chiefly of disintegrated tiles from the pilae and fragments of the opus signinum floor, painted wall plaster, etc., from the room above.

In room 5 were the remains of a good opus signinum floor 4 in. thick, with a quarter-round fillet 3 in. wide and 2 in. high at the junction of the walls and floor (pl. v, fig. 1 A). Most of the other rooms had traces of mortar floors on beds of stone chippings, while a number of fragments of wall-plaster painted in a variety of colours was found in the debris.

It will be seen from the plan that the wall of the Saxon Shore fort passed over the remains of this building and in pl. VIII, fig. 1 A part of the dividing wall between rooms 1 and 2 can be seen immediately below its foundations. Little remained of the walls of room 1, but within it was found the angle of a partially destroyed structure with a fair face of brick backed by flints set in mortar. On its east side was a small patch of opus signinum flooring. This was possibly the base of a raised hearth or oven, but it was at a very low level and may belong to a period previous to the building of the house.

A gully 10 in. wide and 6 in. deep, found running parallel to the west wall of the house and 11 ft. from it, may represent the position of a beam forming the base of a verandah, but owing to the disturbed nature of the soil no further trace of this could be discovered.

Coins of Vespasian found under the floors of rooms 5 and 14 indicate that the house could not have been built before the latter part of the first century. No direct evidence for the date of its destruction was obtained, but nothing that could be definitely assigned to the second century came from the filling of the hypocaust or stokehole, and the greater part of the pottery on or below what must have been approximately the ground-level of the house was distinctly early in character, little subsequent to the early years of the second century being met with.

THE SECOND HOUSE ON SITE III

A considerable portion of the next building on this site had also been destroyed by erosion on the northern and eastern sides, but sufficient remained to identify it as a dwelling-house of some importance (pl. XLI). The rooms 2 to 9 with the corridor or verandah 1 formed part of a western range and 12, 13, 14 part of a southern with the corridors or verandahs 11 and 16 to

the north and south respectively, the latter having a room (15) at its western end. There was probably a stair to an upper story in 10, while 7 appears to have been a vestibule from which doorways led into 6, 8, and 9. No. 3 may have been a similar vestibule, but the walls were not standing high enough to show whether doorways had existed as in 7. No. 17 was an open courtyard.

The complete plan of the house probably conformed either to the well-known type consisting of four ranges of rooms surrounding an open courtyard, or to the variety with one main range from one side of which wings projected at right angles at either end (cf. *Arch.*, vol. lviii, pl. viii, Caerwent, houses II and VII; *Wroxeter Report*, 1914, pl. xxii; Folkestone, *Arch. Cant.*, vol. xxxviii, p. 45). If the house were of the former type, 17 would have been the courtyard, but if of the latter the main range would probably have been the southern, as it contained larger rooms than the western and had a corridor or verandah on both sides.

When this house was built the remains of the floors of the previous one must have been covered with debris 1 ft. to 2 ft. deep. The foundation trenches were dug in this and often cut through the earlier walls and floors. Although the later building had the same orientation as the earlier, the plan was entirely different, as only in a few instances were the walls built on the same lines, and even then apparently more by chance than intention.

The walls were composed of fair-sized waterworn flints with lacing courses of tiles at intervals, the mortar containing grit, small pebbles, and fragments of shells. There were five courses of flints to 2 ft., and the double lacing courses of tiles had a mortar-joint 1 in. to 2 in. thick. The east wall of room 6 (pl. vi, fig. 2) shows the method of construction, which was as follows. A trench having been dug, two or three courses of loose flints were laid in the bottom and on these three or four more were set in mortar until the ground-level was reached. On this the wall, 1 ft. 11 in. wide, was built up in courses of flints, a double lacing course of tiles being laid at a height of 2 ft. 6 in. Above this lacing course was an offset of 2 in. to 3 in. on either side, the wall above narrowing to 1 ft. 6 in. At 2 ft. 6 in. above the offset was a second double lacing course of tiles (pl. vi, fig. 2). The mortar-joints on the face of the wall had been smoothed with a trowel or similar tool, the portion above the offset being more carefully rendered than that below. In the illustration (pl. vi, fig. 2) the portion laid in the foundation-trench is seen with a ragged face, while near the ranging-pole a section of soil has been left, showing a layer of mortar deposited on the surface of the ground at the time the wall was being built. This is a typical example of the walls of the house, but several differed from it in

detail. For instance, the outside wall of the western range had no offsets at the lacing course level, but one on either side, $2\frac{1}{2}$ in. to 5 in. wide, above the third course from the bottom, above which point the wall carried up 2 ft. wide. Again, the eastern end of the outer wall of the south range had an offset of 5 in. to 6 in. on the inner side 4 ft. above the bottom of the foundations, the wall above the offset being 1 ft. 11 in. to 2 ft. wide. An unexplained thickening occurs in the north wall of room 14.

On pl. v, fig. 2 A, can be seen the lower part of the doorway between rooms 7 and 8. The jambs and sill were apparently of wood, as on the surface of the recess for the latter, which was $3\frac{1}{2}$ in. deep and $4\frac{3}{4}$ in. high (pl. vi, fig. 1), the impression of the timber could still be discerned. The sill-level of the three doorways leading out of room 7 must have been approximately the floor-level of the house, which would therefore have been slightly above the offset over the lowest lacing course of tiles, or some 2 ft. 6 in. to 2 ft. 10 in. above the ground-level when the walls were built. This raises an interesting point, as the usual Roman flooring was of cement laid on a packing of stones, tiles, etc., or even directly on the earth itself, but in none of the rooms in this house was there a trace of such a floor or any indication that the space between the surface of the ground and the floor-level had been intentionally filled up for the laying of such floors. It would seem, therefore, that they must have been of wood, supported at intervals on wooden uprights, as the offset, which was only 2 in. to 3 in. deep, could not alone have supplied sufficient bearing for the timbers.

This house was so entirely ruined that no further information concerning it could be obtained except that its walls were decorated with variously coloured wall-plaster, of which many fragments were recovered.

To the west of the house and north of the line of the later outer ditch were distinct traces of a pebble road or pavement.

A roughly-built opening 1 ft. 10 in. high and 1 ft. 2 in. wide, composed of tiles, was found in the dividing wall between rooms 6 and 8 (pl. XLIV, sec. 8, and pl. VII, fig. 1). The offsets at the floor-level had been cut through when it was constructed, indicating that it was obviously an insertion, but for what purpose is unknown.

Owing to the lack of floors in this house there were no sealed or well-stratified deposits that might have afforded evidence for the date of its erection. From general indications there would seem to have been no considerable interval between the levelling of the previous house and the building of this one, so it will not be unreasonable to assume that it was constructed during the first half of

the second century. The similarity of its construction to the main building on site I (*Richborough I*, p. 17), which was dated to about the same period, helps to confirm this. It appears to have been still standing when the third-century earth-fort was formed (p. 19), but its total destruction must have taken place before the building of the Saxon Shore fort, the north wall of which passed over the remains of several of its walls, as can be seen on pl. VIII, fig. 1 B. On the left-hand side of the illustration just mentioned will be noticed a fragment of wall (E) at a high level with a finished face on either side. This, although apparently a separate build, had been incorporated in the north wall of the fort, and its continuation could be traced in that structure where it stood its full width a few yards to the west (pl. XLV). No similar feature has been noticed elsewhere and its purpose cannot be explained, nor is it understood why this isolated portion should have been left *in situ* when the wall collapsed.

THE DEFENSIVE DITCHES WITHIN THE FORT

In 1923 a ditch, which had the appearance of forming part of a defensive work, was found running through the western portion of site I (*Richborough I*, p. 10). The line of this ditch was roughly north and south, but its northern end was found to be turning towards the east. In 1924 a ditch of similar size was discovered to the south of site III, running roughly east and west, and in 1925 this was traced farther to the west and two more ditches were proved to have existed immediately to the north and parallel to it. A re-examination of the ground to the west of the ditch previously found in site I resulted in the discovery of two more ditches at this point also. Although these ditches in site I and the others west and south of site III were not fully explored, there can be little doubt that they were part of the same system, undoubtedly forming the north-west portion of the defences of a fort or camp linked up as shown on the plan (pl. xxxviii). The abrupt ending of the inner ditch on the north side of the main east and west road indicates that there was an entrance at this point (pl. ix, fig. 2), but as no effort has yet been made to trace the ditches on the south side of the road the area and form of the fort are unknown.

To ascertain the exact shape of the ditches or their original depth was fraught with great difficulty, as they had been dug in mixed soil, much of which was subsequently replaced when they were filled in. Also the percolation of the water through the mixed soil had discoloured the undisturbed sand at the bottom, destroying the clean-cut line which originally existed between the sides and the filling. There was only a slight deposit of silt in the bottom and they cannot have been open for any length of time. It was

evident that they had been purposely filled in, much clay being used to consolidate the soil and prevent sinkage as far as possible.

Four sections were obtained (pl. XLVI) and a stretch of both the inner and outer ditch was cleared (pls. VIII, fig. 2 and IX, fig. 1). Section 14 probably gives the most accurate representation of their original form, although the exact ground-level when the ditches were open could not be ascertained, as at the higher levels no definite stratification was discernible. In no instance was there any sign of the main rampart, and this was undoubtedly levelled when the ditches were filled in, but a thin curved layer of stones beyond the outer ditch in section 14 may indicate the contour of a small outer mound. The two outer ditches were of V form, but the inner had a slightly concave ledge or offset on the inner slope some two feet above the bottom. This feature, as explained in the last *Report*, is not unusual, and a theory has been propounded that its purpose was to enable a row of pointed stakes to be set in the side of the ditch in order to strengthen the defences. This was not, however, borne out here, there being no sign of post-holes, which should have been plainly seen in the clean sand had they existed. This ledge was not continuous, there being no traces of it in the stretch immediately to the south of site III or in the portion adjacent to the east and west road to the south of site I (pls. VIII, fig. 2, IX, fig. 2, and pl. XLVI, sec. 13). That this ledge, cut in the undisturbed sand, should have been found clearly defined strongly endorses the theory that the ditches were not open for any length of time. The walls of site I must have been levelled to their present height before the ditches were dug, and section 16 shows very clearly how, after this had been done, the remains of the walls coincided with the contour of the ditches, in the sides of which their ragged ends would have shown.

Whether the house on site I was already in ruins or the builders of this fort purposely destroyed it could not be ascertained. That they did not interfere with the one on site III is obvious, the two outer ditches ending abruptly some ten feet from the west wall, the middle one cutting partly into the foundations of the earlier house, which by then must have been entirely hidden beneath the soil. The inner ditch, however, continued to the south of the building, slightly curving so as to miss its south-west angle. There were indications that this ditch was turning southwards near the edge of the cliff, but its course could not be traced at this point without disturbing the later foundation that had been laid across it (pl. VIII, fig. 2).

Several factors combined against accurate evidence being obtained for the date of the digging and the filling in of these ditches:

they had been dug in mixed soil containing debris of some hundred and fifty to two hundred years of occupation; they were probably filled in again with much of the soil taken out of them; they had not been open long enough for any rubbish to have accumulated in the bottom; and, worst of all, an intensive occupation of a hundred and fifty or more years had taken place over them after they had been filled in, which resulted in the inevitable introduction of later objects. It is not surprising, therefore, that although every effort was made to ascertain their date by taking out the filling in layers and leaving the silt in the bottom to be examined separately, the evidence forthcoming was not of an altogether satisfactory or conclusive character.

There were, however, several points which enabled the date of the formation and of the levelling of this fort to be fixed within certain limits with considerable accuracy. The fact that the ditches cut through the walls of the main building on site I, built during the first half of the second century, clearly indicates that they must be later, and probably considerably later, than that date. That they were filled in before the end of the third century is certain, as the big foundation which was laid down before that date passes across the eastern end of the inner ditch on the south side of site III (p. 6, pl. VIII, fig. 2). This dating is corroborated by the finding of a coin of Claudius Gothicus, A. D. 268-70, in pit 18, which was dug in the filling of the same ditch. These facts point to the ditches having been dug some time after the middle of the second century and filled in again before the close of the third, and even closer dating can be obtained from the evidence afforded by the objects found in this filling.

The filling of the stretch of the inner ditch to the south of site III (pl. XLVI, sec. 13) contained Samian of the first and second centuries and a few fragments that might be as late as the third. There was also the foot of a Rhenish ware beaker probably of the third century. Two pieces of Samian from the bottom of the ditch were of first-century type, but at the same level was the base of a Castor ware vessel, probably of third-century date, and part of a Samian mortarium form 45, a type which lasted well into the same century. There was nothing of late third-century or later date, and the evidence therefore points to this section of the ditch being filled in with mixed soil containing debris of the first, second, and possibly the first half of the third century. Fourteen pieces of the marble casing came from this portion of the ditch.

The filling of the outer ditch immediately to the west of site III (pl. IX, fig. 1) contained Samian ranging from the first to the third century, the majority belonging to the second half of the second

and the beginning of the third century, form 45 being represented by thirty-five fragments. There were also twenty-eight pieces of Rhenish ware of late second- or third-century date, while the greater part of the coarse ware belonged to the period between A. D. 150 and 250. There was only one fragment, a portion of a Marne ware bowl, that could be assigned to the fourth century. Several fragments of first-century Samian were found near the bottom. A coin of Tetricus, A. D. 268-73, was 3 ft. down in the filling, two with radiate crowns *c.* 260-96 at 2 ft., and another, probably of the same type, at 1 ft. A coin of Hadrian, A. D. 117-38, also came from the filling, as did twenty-one pieces of marble casing. The evidence from this stretch of ditch suggests that the filling in took place during the third century. The coins point to a late date in that century, but too much reliance must not be placed on them owing to the ease with which they work down from higher levels. The early Samian found in the bottom may have fallen from the sides, a considerable deposit of that date having been cut through when the ditch was dug.

In section 14 (pl. XLVI) the filling of the inner ditch contained three fragments of decorated Samian, two Antonine and one late second century, also fragments of forms 27 and 33, the mouth of a flagon A. D. 80-120, a late second-century mortarium rim and two of the late second or third century, a coin of Nero, and a piece of marble casing. At the bottom were two more pieces of marble, while in the middle ditch was another, and in the outer two pieces. Here again the ditches appear to have been filled in with mixed soil containing articles of the first to third centuries.

Section 15 (pl. XLVI) was difficult to elucidate owing to the disturbed nature of the soil. The dividing wall between rooms 9 and 10, site I, had, with the exception of a few stones, been entirely removed when the inner ditch was dug, while the west side of the middle ditch cut through the filled-in drain of the building. Little was found in this section except fragments of two poppy-head beakers and a bowl of the second century or later in the filling of the middle ditch; a denarius of Caracalla, *c.* 200, occurred near the bottom of the outer ditch, and a coin of Claudius I, A. D. 41-54, was found 3 ft. above it in the filling. The inner ditch at this point was cleared in 1923 (*Richborough I*, p. 10), when only a few fragments of pottery were found, some being of the second century or slightly later. The evidence from this section again points to the ditches having been filled in with mixed soil containing debris of the first to the third century.

In section 16 (pl. XLVI) the greater part of the filling of the ditches had been removed when the foundations of this part of site I were uncovered in 1922-3 and before the existence of the ditches at

this point had been recognized. In consequence only a little of the filling remained to be examined, and this contained nothing except the bronze statuette (pl. xxiii, 65), probably of second-century date, which was found in the bottom of the middle ditch.

A stretch of the inner ditch was cleared on the north side of the main east and west road, on the edge of which it ended abruptly with a vertical side (sect. 17, pl. xlvi and pl. ix, fig. 2). The filling here contained forty-three fragments of decorated Samian, ranging in date from Flavian to Antonine, two fragments of form 15, one of form 18 with the stamp OF IVCVN, five of 31, seven of 33, one of 46, and two of 45, one of 79 with a stamp of CVCALVS, a Castor ware hunt cup, a late second- or third-century mortarium, several black dishes with beaded rims or flanges, a red-coated, rosette-stamped bowl, a Theodosian coin, A. D. 388-92, and forty-four pieces of marble. In the silt at the bottom were two fragments of form 37 of late second-century type, one of form 27, one of 79, a coin of Nerva, A. D. 96-8, and one piece of marble. Here again the evidence points to the filling in having taken place after the close of the second century and before the end of the third, as the Theodosian coin and the fragment of the rosette-stamped bowl may be dismissed as intrusions from the later occupation.

The evidence as a whole points to the ditches having been filled in during the third century, and the comparative lack of coins of the second half of that century in the filling, although very large quantities of that period have been found in the soil above, suggests that the fort was levelled at a date not far removed from A. D. 250. The fact that quite a considerable amount of pottery, that might belong to the first half of the third century, came from the filling of the ditches helps to confirm this dating. How long the fort may have been in use before it was levelled cannot as yet be decided, but the ditches show little sign of having been open for any length of time, and further excavation will probably confirm the general impression conveyed that its existence was of short duration.

THE FOUNDATION OF A FORT WALL IN SITE III

In point of date the large foundation running north and south through site III is the next structure to be dealt with (pls. iv, fig. 2, x, figs. 1 and 2, xi, fig. 1, xxxix and xliv, sec. 12). It consisted of a packing of stones—mostly water-worn flints—1 ft. to 2 ft. deep and 13 ft. to 14 ft. wide, capped with a carefully-levelled layer of chalk a few inches thick. The cavities left by the decayed wood of two parallel rows of vertical piles some 3 ft. to 4 ft. apart were discovered running the whole of its length. These piles, which had been embedded in the stone packing and did not penetrate through

its surface, varied from 9 in. to 14 in. across at the top tapering to a point at the bottom, having been driven some 4 ft. into the soil below (pl. xi, fig. 1). It will be seen by referring to section 12 (pl. XLIV) that the level of the foundation varied considerably. This can be accounted for if the builders only considered it necessary to lay it at a uniform depth beneath the existing surface-level, which was probably higher over the ruins of the building on site III, where there must have been an accumulation of building rubbish, than to the south, where no buildings had existed. The walls of the second house had been destroyed to their present level before the laying down of the foundation; but their presence was known, as the changes in level coincided with them in each instance and two had been lowered to conform approximately with the surface of the chalk capping. In no instance was the packing of stones carried over any of these walls. The most northerly portion was much destroyed, but some of the chalk capping was *in situ* and there can be little doubt that it had been only 1 ft. thick and not 2 ft. as elsewhere (pl. iv, fig. 2). Except where the scanty remains of the walls of the first house and the filling of the inner ditch of the fort underlay it, the foundation had been placed on or sunk into the natural soil. Two pits—nos. 16 and 26—had been dug through it; the former contained coins, etc., as late in date as the end of the fourth century, but the latter had been filled in before the end of the third century (p. 33). The ground-level when this pit was dug was at least 3 ft. above the top of the foundation. The southern portion could not be completely examined owing to the presence of the apse of the chapel above (pl. x, fig. 1), but it was traced to the edge of the bank both at this and the northern end, where in each instance it had a ragged end, having been broken away by the erosion of the site (pl. XLII). The significance of this foundation is dealt with on p. 6.

The small isolated portion of the north wall of the Saxon Shore fort (p. 18 and pl. VIII, fig. 1) had a similar foundation of packed stones. A section showing the chalk and stone packing under the broken east end of the north wall is given on pl. XLV, but it is somewhat confused owing to modern underpinning and the remains of the early house on which the wall had been built. There was a beam-hole under the middle of the wall at this point. Section 18, pl. XLVI shows the edge of the foundation a little farther to the west, where it was again of stones and chalk, and here again, as in section 14, there was evidence that the outer edge of the masonry had rested on a beam. It has recently been discovered that the walls of the Saxon Shore fort at Pevensey stood on a timber framing embedded in the surface of a chalk and stone foundation, and the

presence of beam-holes in the same position at Richborough indicates that a similar method of construction was also adopted there.

THE BATH BUILDING, SITE III

Whatever may have been the fate of the second house on site III, its walls were still standing above ground when the next building was erected, as several were incorporated in it. This building was much smaller than either of its predecessors, consisting of only four rooms forming a minor bath of usual type (pl. XLII). Room no. 3 was the vestibule or dressing-room, no. 4 the cold bath, no. 2 the warm room, and no. 1 the hot room. Both 1 and 2 were fitted with hypocausts, and there was an apse on the north side of the former which may have contained a small hot-water bath. The furnace was situated on the west side of no. 1. The north walls of rooms 2 and 3, the dividing wall between them, the south wall of 2, the west wall of 4, as well as part of the south walls of 1 and 3, had been built upon the remains of those of the earlier building. The later masonry could easily be distinguished from the earlier, as the latter was composed of water-worn flints and the former of ashlar and chalk blocks with mortar-joints as much as two inches wide in places. Where the wall stood highest there were indications of a double-lacing course of tiles with a mortar-joint of $1\frac{1}{2}$ in. (pl. iv, fig. 1). The mortar was a dirty white colour, containing grit intermixed with large pebbles and shells, some being whole oyster-shells. The north and east walls of room 4, the east wall of room 3, and part of its south wall, which were not built on the earlier walls, were 1 ft. 11 in. wide, standing on a foundation of two courses of rough ashlar, which projected 4 in. and rested on two courses of flints set in mortar with a layer of packed flints below (pl. iv, fig. 2). These courses of flints battered outwards some six to eight inches. The south-west angle of room 1 was also not built on an earlier wall, and owing to the presence of the hypocaust it had been carried down to a depth of 5 ft. below the floor-level (pl. iv, fig. 1).

The hypocaust had a cement floor 4 in. to 6 in. thick containing fair-sized pieces of chalk, tile, stone, etc. The pilae were composed of tiles showing signs of heavy burning. They were of various sizes, irregularly spaced, and did not stand on the floor but on a layer of burnt matter covering it, strongly suggesting a reconstruction of the building in a careless and unskilled manner. The most complete pilae stood 2 ft. 6 in. high, probably the full height. The piers carrying the dividing wall between rooms 1 and 2 were built up in tiles, flints, and chalk blocks. What remained of the apse and the wall adjoining it to the west was of

very poor masonry, as were the walls of the furnace, and this part of the house had also evidently been unskilfully rebuilt.

The cold bath, room no. 4, had undergone several changes, which are fully illustrated on pl. XLIII and therefore do not need a detailed explanation here. It was entered from the dressing-room or vestibule between two brick piers which probably carried an arch. In the first instance the bath was rectangular, being only 6 in. deep, with a floor of opus signinum, and there were traces of a similar floor in the dressing-room at the level of the entrance-sill. There was a water outlet in the north wall. In the second build a lining of brick was inserted making a new and smaller octagonal bath; the floor-level was raised, as was also the entrance-sill, which formed a step from the dressing-room into the bath. It is probable that the octagonal brick lining did not carry up to the ceiling but formed a bench round the walls. In the third build the octagonal bath was filled in with cobbles and rubbish and a small rectangular bath constructed within a hexagon. The floor-level of the dressing-room was also raised and a new step placed in the entrance to the bath. The original water outlet may still have been used by connecting it with the bath by a lead pipe. In the fourth build, the bath, which had a quarter-round fillet at the junction of the floor and walls, was made smaller still, a wall of rough masonry being built round it upon the earlier hexagon, and the entrance-sill raised again in the same material. The outlet was this time taken through the entrance, the water probably being carried by a lead pipe under the floor of the dressing-room to the outlet in its east wall.

A coin of Tetricus I, A.D. 268-73, was found under the lower floor in the dressing-room, indicating that the building was later than that date. The foundations of the south-east angle overlay the large foundation described on p. 22, which must therefore be earlier in date than the bath building (pl. XLII). There was no means of ascertaining how long this building continued to be used, but in view of the numerous alterations and rebuildings there is every reason to suppose that it did not fall into decay until the final abandonment of the site by the Romans.

OTHER BUILDINGS WITHIN THE FORT

The only indications of other habitations within the walls of the Saxon Shore fort were layers of burnt matter, hearths, irregular patches of cobble pavement, and occasional pits or wells. The hearths were mostly composed of tiles laid on clay and were generally surrounded with burnt matter, often containing fragments of daub bearing the impression of wattle. Here and there were layers of clean sand possibly representing the floors of huts.

An irregular layer of clay, thickly covered with burnt matter, situated a little to the north of pits 23 and 24 and immediately over the filling of the inner ditch, was most carefully examined (pl. XLII). This layer of clay, which probably formed the floor of a hut, measured at its greatest width some 16 ft. It was about 6 in. thick in the centre, but became very thin towards the edges, which were so extremely irregular that it was not possible to determine the original form. Near the centre was found a vertical cavity 6 in. in diameter and 12 in. deep containing large stones which may have served as the packing for an upright stake. Near by was found a hollow, conical iron shoe, 11 in. long and $2\frac{1}{2}$ in. across at the top, of a type fitted to stakes or piles to enable them to be driven into the soil. On the north side of this central hole was a bed of burnt clay mixed with charcoal measuring 2 ft. long, 1 ft. 6 in. wide, and 1 ft. 3 in. deep, possibly the site of a hearth. A very similar bed of burnt clay and charcoal occurred on the eastern side of the floor. The texture of the floor varied greatly from point to point; for the most part it consisted of soft, burnt clay mixed with fine charcoal, but at one point the heat had been great enough to convert it into a moderately hard brick, suggesting that a fire had been maintained there for some time. Many iron nails were found in the burnt matter overlying the floor, which also contained some very fragmentary pottery indeterminate in character. A few coins were also found on or near the floor, among them one of Postumus A.D. 258-267, and several barbarous examples of the radiate head type. The majority, as far as could be ascertained, belonged rather to the second half of the third century than to the fourth.

Two other hearths surrounded by burnt matter lay to the west of site III. These also probably represented the sites of huts, and the pottery and coins found in their vicinity indicated that they were of late third or fourth century date. Three barbarous coins of the radiate head type were lying close to a hearth which had been built against the north wall of the fort (pl. XLII, sec. 18).

Irregular layers of pebble and flints occurred indiscriminately, and although an endeavour has been made to place the most pronounced on the plan they varied in depth, thickness, and consistency to such an extent that it was impossible to ascertain their exact limits or purpose (pl. XLII). The finds from several were carefully examined, but beyond the fact that practically all the coins belonged to the second half of the third and the fourth century no useful information could be obtained. The whole of the top three feet removed contained thousands of coins of this period as well as a few of earlier date. One collection of seventy-four (p. 118) was found

lying together to the south of site III, but otherwise they were distributed casually in the soil, the most prolific areas being immediately to the north and west of the great concrete foundation.

At the edge of the cliff on the east side of site III, and only just under the surface, was a long stretch of wall in which was an opening with a stone sill (pl. XLII). There were indications that this wall had returned westwards at the southern end. It was built of stone and flint set in a dark-coloured mortar containing large quantities of broken shell, and quite unlike any other on the site. Its purpose is not known and it may possibly be post-Roman.

THE PITS

In the last *Report* (p. 24) it was pointed out that several of the deepest shafts were probably used as wells. Of those described below, no. 20 was certainly made for that purpose as were also nos. 16 and 17, in both of which water was standing at the bottom. No water was encountered in no. 26, possibly because of its proximity to the edge of the cliff, but its shape and depth suggest that it was originally dug for a well. The smaller shafts may have been used as latrine pits or simply for the disposal of rubbish. Only one pit, no. 20, was filled in during the first century, and there was none of c. A.D. 100 although the majority found in the previous excavations was of that date (*Richborough* I, p. 24). It was there suggested that these pits were connected with the huts and workshops of the artisans employed on building the platform and the structure which it carried. Their absence in the more recent excavations is perhaps due to the fact that the portion of the site examined was used when these building operations were in progress for the dressing of stone, the mixing of mortar, etc. (p. 11). Two of the pits, nos. 18 and 26, were of late third century date, while the remainder must have been filled towards the close of the occupation or even in post-Roman times.

Pit 16 was 33 ft. in depth below the modern surface level and 8 ft. in diameter. The filling consisted almost entirely of building rubbish, in which were the following coins: at 18 ft., one of the House of Theodosius A.D. 388-395; at 22 ft., one Gallienus A.D. 254-268, and four illegible of the fourth century; at 22 ft. 6 in., one Trajan A.D. 104-111, one Claudius Gothicus A.D. 268-270, one Honorius A.D. 388-395, and one illegible, fourth century. There were only a few fragments of pottery, among them the Samian forms 27, 31, and 37, and the late red-ware types 103-4, 107, 109-12, 113, and one of type 97. Twenty-seven pieces of marble came from this pit, which appears to have been filled in towards the end of the Roman occupation or even later.

Pit 17 was an irregularly-shaped pit some 13 ft. to 16 ft. across the mouth and tapering to 7 ft. 6 in. near the bottom. Water was met with before the bottom was reached, and owing to the sides beginning to fall in the complete clearing of this pit had to be abandoned at a depth of 38 ft. from the surface. The filling consisted of a mass of building rubbish of every description, the only coin found being one of the House of Theodosius, *c.* A. D. 388-395, at 13 ft. down. Among the few scraps of pottery were the Samian types 27 and 82, and two of the late red-ware type 109-12, one of type 103-4, and a fragment with stamped rosette decoration.

Several large pieces of wood were found at the bottom, including a 6 ft. 6 in. by 2½ in. plank and a pointed stake 5 ft. 3 in. long. The latter had two 3-in. chases cut in it and the greatest thickness was 4½ in. by 6½ in. There was also part of another stake (pl. VII, fig. 2).

This pit appears to have been filled in towards the close of the Roman occupation or even later.

Pit 18 was dug in the filling of the inner ditch and was 11 ft. 8 in. deep and 5 ft. 2 in. in diameter. The filling was almost entirely composed of pieces of burnt daub showing the impression of wattle. With these was a coin of Claudius Gothicus A. D. 268-270, and two illegible fragments of a third brass. The pottery consisted of two worn and late fragments of Samian form 37 and one each of forms 31 and 45. There were also a few scraps of coarse pottery and the cheese press (pl. xxxi, no. 152), but no examples of the late red-ware. It would seem that the debris from a burnt wattle-and-daub hut had been deposited in this pit towards the close of the third century A. D.

Pit 19 had been dug through the foundations of the second house, site III. It was 12 ft. 7 in. deep and irregular in shape, the greatest width being 10 ft. 6 in. It contained a certain amount of building rubbish and some burnt daub showing the impression of wattle. There were no coins. The pottery included three fragments of Samian, one of form 15 and two of 31, and a mixed collection of coarse wares, some with painted patterns and apparently as late in date as the fourth century. Three pieces of marble came from this pit.

Pit 20 was 20 ft. from the east side of the concrete platform, and its discovery was due to the presence of a pronounced dip in the mortar layer which at a depth of 4 ft. to 5 ft. extended over this part of the site (p. 10). Upon examination it was found that the mortar layer, which was 4 in. to 6 in. thick at this point, had, owing to the subsidence of the mixed soil below, cracked and

fallen into the mouth of a shaft 28 ft. deep and 6 ft. 10 in. in diameter. Between the mortar layer and the natural soil surrounding the mouth of the shaft was a layer of pebbles and rubble with a band of mixed soil below. These layers appear to have originally extended over the filled-in shaft, and together with portions of the mortar layer had sunk in the mouth as the soil below subsided. After the top 6 ft. to 8 ft. had been cleared out indications of a smaller shaft were noticed in the centre, which at a depth of 15 ft. became well defined and nearly circular in shape, measuring 2 ft. 6 in. by 2 ft. 9 in. These two shafts continued to the bottom, the inner being lined with clay while the space between it and the side of the larger shaft was packed with clean sand. There were no definite traces of a wood lining to the inner shaft, but it is more than probable that one had existed and that the construction was very similar to that of pit 7 (*Richborough I*, p. 22), except that in this case the inner shaft was not rectangular.

This shaft was certainly a well in the first instance, and after falling into disuse became a convenient place for the deposit of rubbish. The objects found in the filling are dealt with in detail below, as they not only form an interesting and closely dated deposit but also supply the most definite evidence yet obtained for the very early date of the first occupation of the site. The depth measurements were taken from the mortar layer.

The objects in the top 6 ft. to 8 ft. of the shaft were not of such an early character as those lower down and were probably introduced into the mouth during the occupation that took place subsequent to the filling of the lower part of the pit, but before the formation of the mortar layer. They consisted of a number of small fragments of Samian, including several of form 29 of the Nero-Flavian period, and of forms 15, 18, and 27. There were also two or three portions of gray urns with high shoulders, one piece with horizontal combing (pl. xxix, fig. 2, no. 1), the flagon (pl. xxx, no. 139), and some blue glass. A human jaw-bone was found at 8 ft. to 10 ft. down. There was not sufficient evidence to fix the final date of this deposit, but the absence of form 37 suggests that it was not later than Flavian times.

The various articles found between 8 ft. to 10 ft. and 15 ft. appear to have been deposited either during the late Claudian or Neronian or early Flavian period. They consisted of the mortarium (pl. xxx, no. 141), fragments of a lamp, a small cup (*Richborough I*, type 59), portions of furrowed ollae, and several large pieces of a bulbous amphora. At 15 ft. the inner shaft became well defined, but little was recovered from it until 22 ft. was reached except one piece of Samian, form 15, and parts of a furrowed olla. Between 22 ft.

and 24 ft. were more fragments of furrowed ollae (pl. xxx, no. 136), pieces of two straight-sided amphorae, and the flagon neck (pl. xxx, no. 138). In the next 3 ft. a very interesting series of articles was met with, intermixed among them being the remains of a wood and iron box with bronze fittings. This box was found in innumerable fragments of various sizes, but as all of these were close together it may have been thrown into the shaft intact and subsequently become crushed and disintegrated. It appears to have consisted of thin sheet iron and wood bound with iron bands and decorated with bronze fittings. A fragment showing two of the iron bands crossing each other is illustrated on pl. xv, fig. 1, no. 19, while no. 16 is one of these bands with a bronze disc riveted to it. All the other objects on pl. xv, fig. 1 appear to be parts of this box. Nos. 1 and 2 are bronze drop handles which had been fastened to the sides through bronze discs by split pins of the same metal. No. 3 is of thin bronze and appears to be the remains of a central ornament consisting of concentric circles and six hollow bosses with concave tops. Nos. 4-7 are fluted bronze rings; attached to one is part of a bronze and to another part of an iron looped rivet, which seem to have passed through bronze discs similar to nos. 16 and 17 and to have been used for suspension or drop handles.¹ Nos. 8, 9. Bronze castings moulded on one side and flat on the other, may have been purely ornamental fittings. On each are parts of two bronze split rings for attaching them to the box. No. 10. Six portions of bronze chain with split pins and a bronze ring with slight remains of two similar chains attached to it. No. 11. Thin bronze disc held by a broken split pin to an iron band. No. 12. Portion of rather thicker, much corroded, bronze disc with traces of a silver wash and decorated with incised circles. A small bronze loop may be seen in the illustration attached to the face near the upper edge. No. 13. Piece of thin bronze, originally a square plate with rivet holes in the angles and decorated with concentric circles and a central knob. No. 14. Plain sheet of thin bronze pierced with a short bronze rivet (?) with a flattened, rounded head. A small bronze lever on the front attached to a thin bronze plate on the back, enabled the latter to be moved so as to form a shutter for some opening such as a keyhole. No. 15. Hinge with engraved lines. The upper portion is of thin bronze, the lower is thicker with a square-section rivet at the back, and the left-hand side is attached to a thin sheet of bronze in which is a small round-headed nail. No. 16. Part of a circular boss attached to an iron band by a bronze

¹ Very similar iron rings attached by rivets to the iron bands of a wooden bucket were found at Aylesford. *Arch.* lii, 319.

rivet. No. 17. Very similar to the last but with an iron rivet. No. 18. Object of thicker bronze with traces of silver wash engraved with incised concentric circles and a small central knob. Attached to it is a bronze bar with a rivet in the back. No. 19. Portion of the side of the box showing two crossed iron bands held to a thin sheet of iron by iron rivets. There are remains of wood at the back. There was also a number of fragments of thin bronze, some showing traces of embossed decoration, thirty small bronze nails with thin circular concave heads and six with solid round heads.

Intermixed with and near the remains of the box were the following articles (pl. xiv, fig. 2). No. 1. Ten opaque glass counters, one yellow, two black, and seven blue. Nos. 2, 3. Bronze spoons. No. 4. A bronze rod. No. 5. A bone spoon. No. 6. Four blue paste beads. No. 7. Small irregular piece of opaque blue glass. Nos. 8, 9. Two of sixteen sestertii (p. 119). Several of these were corroded together, suggesting that originally they were in some receptacle such as a bag or purse. No. 10. Part of a stone palette with bevelled edges. These palettes formed part of a lady's toilet outfit and were used for paint mixing. No. 11. Half an amber bead. No. 12. Bronze fluted patera or pan handle terminating in a ram's head. Pl. xv, fig. 2. A pair of iron shears to which was held by corrosion a long thin bone comb having a row of fine teeth at one end and cut diagonally across to form a point at the other. Both the shears and the comb were probably used in connexion with weaving. Portions of an iron and wood case or sheath were attached to the shears, and the whole appears to have been wrapped in linen the impression of which could be plainly seen. Other objects not illustrated include a number of hobnails from the soles of boots, several iron nails, staples, etc., an iron padlock, and other articles of the same metal too corroded to identify. There was also a slab of clay-stone (p. 105) 12 in. by $7\frac{3}{4}$ in. by $1\frac{1}{4}$ in. with a finely polished surface, with which was a disc of the same material, $4\frac{1}{4}$ in. in diameter, having one side smooth and the other rounded. This disc, which was obviously made to fit the hand, was probably used for rubbing down or mixing some substance such as paint upon the smooth surface of the flat slab. In close association with these were found parts of a pottery lamp, fragments of several cups with various forms of decoration (*Richborough* I, type 59), the flagon neck (pl. xxx, no. 137), and pieces of furrowed ollae. Lower down were parts of a straight-sided amphora with peaked handles, more furrowed ware (pl. xxx, no. 135), and the bowl (pl. xxx, no. 140). The bottom was reached at 28 ft. from the mortar layer or about 33 ft. from the modern ground-level. There was no water at the bottom although the soil was distinctly moist.

To explain satisfactorily the presence of such a curious assortment of objects in the lower part of this shaft is impossible. Some had certainly been discarded as worthless, but it is difficult to believe that the sixteen sestertii were purposely thrown away or had accidentally got into the pit. Some of the articles such as the weaver's comb and shears, the large smooth stone palette and rubber, the beads and counters were undoubtedly serviceable as other of the objects may well have been at the time of deposit. The fact that fragments of the box and the sheath of the shears clearly showed the impression of linen suggests the possibility that this collection of objects may have been wrapped up in a bundle and let down into the shaft for concealment, the hider never having had the opportunity of recovering them.

The sixteen coins, all probably minted early in the reign of Claudius (p. 119) are good evidence for the date of this deposit, which can hardly be later than his reign and may well be within a year or two of the striking of the coins as they show little sign of wear. It follows, therefore, that the sinking of the well must have taken place at the time of the invasion in A.D. 43 or very shortly afterwards, and the presence of weaving implements, toilet articles, etc., in the filling indicates some form of domestic settlement on the site by the middle of the first century A.D.

Pit 21 was 12 ft. deep and 4 ft. in diameter. It contained two coins of Tetricus A.D. 268-273, three with radiate heads A.D. 260-296, and three Constantinian A.D. 330-337. The pottery was very fragmentary and of little interest; it included a few scraps of Samian and the late red-coated ware.

This pit would seem to have been filled in about the middle of the fourth century.

Pit 23 was sunk 5 ft. 6 in. below the 3-ft. level and was roughly rectangular, measuring 5 ft. by 3 ft. 6 in. Near the top was a coin of Tetricus A.D. 268-273, and a barbarous radiate *c.* A.D. 260-296. At 3 ft. down was a Helena *c.* A.D. 337-340, and at the bottom a broken coin, probably Carausius A.D. 287-293. Among the pottery fragments were the late red-ware types 104, 113, and a fragment with rosette-stamped decoration. One piece of marble and eighteen iron nails came from this pit which appears to have been filled in about the middle of the fourth century.

Pit 24 was rectangular, 4 ft. 8 in. by 4 ft. 1 in., and had been sunk to a depth of 16 ft. 2 in. below the 3-ft. level. It contained the following coins: at 2 ft. 6 in. one Constantine A.D. 335-337; at 3 ft. one Valentinian II A.D. 388-392; at 5 ft. 6 in. two Constantinian *c.* A.D. 340; at 7 ft. 6 in. one Crispus A.D. 320-324; at 9 ft. one Claudius I A.D. 41-54, two Constantinian A.D. 320-

337, one Theodosian A. D. 390-395 ; and at 12 ft. one Constantianian A. D. 335-337. The pottery included a few scraps of Samian, among them a 15, a 46, and a fragment with cut-glass decoration. There was one fragment of each of the red-ware types 107, 108, 109, and one decorated with white paint, probably type 113. There were also four pieces of marble and six iron nails.

It would seem that this pit was filled in towards the close of the Roman occupation or even later.

Pit 26 was 12 ft. in diameter and 24 ft. 9 in. deep measured from the top of the supposed foundation of the east wall of the Saxon Shore fort through which it had been cut (pl. x, figs. 1 and 2, p. 23). There were indications that the ground-level when this pit was dug was at least 3 ft. above the top of the foundation and that the mouth had been filled with stones and building rubbish among which was a coin of the radiate head type. The following coins came from lower down in the filling, the depth measurements being taken from the top of the foundation :

1 ft. to 3 ft.	2 Tetricus	268-273
"	10 Radiate heads	c. 260-296
"	3 probable ditto	
3 ft. to 6 ft.	2 Gallienus	254-268
"	4 Tetricus, 1 barbarous	268-273
"	2 Claudius Gothicus	268-270
"	12 Radiate heads	c. 260-296
6 ft. to 9 ft.	1 Faustina Junr.	c. 160
"	1 Gallienus	254-268
"	2 Tetricus, 1 barbarous	268-273
"	2 Radiate heads	c. 260-296
"	about 10 corroded fragments, apparently radiate heads	
9 ft. to 12 ft.	2 Gallienus	254-268
"	1 Claudius Gothicus	268-270
"	4 Tetricus, 2 barbarous	268-273
"	18 Radiate heads, many barbarous	c. 260-296
"	8 corroded fragments, apparently radiate heads	
12 ft. to 15 ft.	1 Claudius Gothicus	268-270
"	2 Tetricus	268-273
"	9 Radiate heads, 5 barbarous	c. 260-96
"	4 corroded fragments, apparently radiate	
15 ft. to 18 ft.	2 Gallienus	254-268
"	1 Tetricus	268-273
"	28 Radiate heads, including 10 barbarous and 5 minimi	

18 ft. to bottom	1 Faustina Junr.	c. 160
„	1 Æ 2	probably second century
„	1 Radiate head, fragment	c. 260-296

A summary shows that the pit contained two coins of Faustina Junr. c. A. D. 160 and one other probably of second-century date, seven of Gallienus A. D. 254-268, four of Claudius Gothicus A. D. 268-270, fifteen of Tetricus A. D. 268-273, four of them barbarous, eighty unidentifiable or barbarous with radiate heads and twenty-five of apparently radiate head types. The latest datable coin was therefore minted before A. D. 273, and as the twenty-two examples with radiate heads that could be definitely dated all fall in the period A. D. 254-273 it is probable that those of similar type but which could not be assigned to any particular emperor were of the same date. In any case they cannot have been deposited much after c. A. D. 296, the date when the official minting of coins with radiate heads ceased. The earliest possible date for the filling of this pit is A. D. 268. That it was slightly later is probable, but the lack of coins of Carausius and Allectus or of the early fourth century indicates a date before the close of the third century.

The pottery from this pit was very fragmentary and of little interest, Samian ware being represented by twenty to thirty fragments of the late first century onwards. There were portions of several beakers mostly coated with brown slip and often decorated *en barbotine* of which pl. xxxiv, no. 185, is a good example. No rosette or similar stamped vessels were met with and the late red-coated ware was entirely wanting. There were a dozen pieces of the marble casing, but on the whole the filling contained very little building rubbish, being entirely different from that of pits 16, 17, and 19.

THE CHAPEL OF SAINT AUGUSTINE

Some 40 ft. to the south of site III and immediately below the surface fragmentary foundations were encountered, and there can be little doubt that they represent all that now exists of the chapel dedicated to Saint Augustine which is known to have stood within the walls of the fort (pls. III, fig. 1 and XLVII). Intermixed with the soil in the vicinity of these foundations were large numbers of waterworn flints which on the northern side of the building were packed so close together that they had every appearance of being a roadway. It was, however, eventually discovered that these cobbles did not extend for any distance westwards nor to the edge of the cliff to the east, and in all probability they were only the fallen and disintegrated walls of the building.

The chapel had obviously been surrounded by a graveyard as

the top 3 ft. to 5 ft. of soil contained numerous human bones. The majority of these were scattered indiscriminately but here and there a complete skeleton, generally orientated east and west, was met with. The only burial found within the walls of the chapel—and even this may have been outside the earliest church—was that of a child in the east end of the chancel.

As well as many Roman objects such as are found everywhere within the fort, several fragments of stained glass, probably of fourteenth-century date, a portion of a Purbeck marble slab, and a few pieces of medieval pottery came from this site. The following coins were also found in the vicinity of the chapel :

Two sceattas.

Two pennies of Offa 757-796.

One double tournois of Philip le Bel 1285-1314.

One penny of Richard II struck at York 1377-1399.

One penny of Edward IV struck at York 1465-1476.

Two Nuremberg counters of the fifteenth century.

One sixpence of Elizabeth 1565.

One Nuremberg counter of Hans Krauwinckel 1588-1612.

One grano of Emmanuel de Rohan, Grand Master, Knights of Malta, 1776 ?.

No architectural details that might have belonged to the chapel were discovered.

In 1205-1206 the presentation to the church of Fleet was in the family of Bolbeck, and Helewisa de Bolbeck, grandmother of Constance de Bolbeck, then the wife of Elias de Beauchamp, had previously possessed the advowson (*Abbreviatio Placitorum*, p. 47). It may be accepted that the church of Fleet and that within the walls of Richborough are identical, as the latter place is mentioned in the appointment of half a knight's fee in the Manor of Fleet between Elias de Beauchamp, Constance his wife, plaintives, and Roland of Avranches, tenant (Feet of fines, 4th June 1197, Kent, Richard I, no. 14, *Pipe Roll Soc.*, vol. xx, p. 125, no 162 : the extent of the Manor of Fleet is given in Inquis. p. m. 48 Hen. III, no. 26, and is quoted in *Arch. Cant.*, vol. v, pp. 292-3).¹

In October 1294, the Prior, etc., of Christ Church, Canterbury, *Sede Vacante*, after the death of Archbishop Peckham, held a visitation in the chapel when Sir Hugh was chaplain. It was then stated

¹ I am indebted to Miss Rose Graham, F.S.A., for the following additional evidence that Fleet and Richborough chapel were the same. In 1287 archbishop Peckham made Wingham a collegiate church with six dependent chapels including Fleet (*Arch. Journ.* lxxiv, 158-9). In 1511 these six chapels are again mentioned (Warham's Register, fo. 37), but in 1535 when the salaries of the priests serving them were given, Richborough was substituted for Fleet (*Valor Eccl.* i, 36).

that 'the font of the same chapel is without a lock and the roof is in bad repair, as was found last year, wherefore it was decreed that the parishoners be enjoined to repair the said defects before the Feast of St. Michael under penalty of half a marc' (*Arch. Cant.*, vol. xxxii, p. 167). The chapel is mentioned in several Ash wills (*Arch. Cant.*, vols. xxxiv-xxxvii), and in one dated 1476 it is termed the chapel of St. Augustine.

Leland in the reign of Henry VIII says that 'Withyn the castel is a lytle parochie churche of S. Augustine, and an heremitage. I had antiquites of the heremite the which is an industrius man.'¹

In 1549 on the dissolution of the Chantries the chapel was sold, mention being made that it was covered with shingle and of little value (*Misc. Bks., T. R., Partic. for Grants*, vol. 258, fol. 21). The chapel, however, was still in use as late as 1601 (*Cal. S. P. Dom.* 1598-1601, p. 531).

Thorn,² a monk of St. Augustine's, Canterbury, writing in the late fourteenth century, makes the following statement³ concerning the landing of St. Augustine and the chapel at Richborough: 'They came ashore in the isle of Thanet, at the place called Retesborough, where our father Augustine, as he stepped out of the ship, happened to stand upon a certain stone, and the stone took the impression of his foot as if it had been clay. In consequence of this event, the stone was taken and honourably placed inside the saint's chapel there; and every year on the day of his burial crowds of people gather there for devotion, and in the hopes of recovering health, saying, "We will worship in the place where his feet stood".'

Bede (I, chap. xxv) makes no mention of a landing at Richborough. His account is as follows. 'On the East of Kent is the large Isle of Thanet containing according to the English way of reckoning 600 families, divided from the other land by the river Wansum which is about three furlongs over and fordable only in two places, for both ends of it run into the sea. In this Island landed the servant of our Lord, Augustine, and his companions, being, as is reported, nearly 40 men.' He then recounts how the king ordered them to stay in the island where they had landed while he considered what should be done with them. After some days the king came into the island and having heard St. Augustine gave him permission to reside in the city of Canterbury.

¹ *Itinerary* (ed. Toulmin Smith) iv, 62.

² Much of his information was derived from the no longer extant history of the second half of the thirteenth century compiled by Sprott, also a monk of St. Augustine's.

³ Twysden, *Decem Scriptores*, x, 1759.

In the *Sandwich Manuscripts*, a compilation from ancient documents, printed by Mr. Boys in his *Collections*, p. 838, is the following account which, although probably legendary, is of interest in connexion with the landing of the Saint. 'Upon the East Coast of Kent lyeth the Isle of Thanet, where Augustine and his fellows landed . . . which thing the King heareing, came shortly after into his pallace or castle of Rupticester, or Richborrow, situate nigh the old city of Stonehore, and the King sitting under the cliffe or rock whereon the castle is built commanded Augustine with his followers to be brought before him.'

It is therefore obvious that in the fourteenth to sixteenth centuries the tradition that the Saint landed at Richborough was firmly established, but it is curious that Thorn who as Treasurer of St. Augustine's—only some ten miles from Richborough—must have known the place well should have stated that it was in Thanet. Mason in *The Mission of St. Augustine* (p. 228) believes that the first landing actually took place at Richborough and argues that as it was an island, although nearer the mainland than to the Isle of Thanet, it was accounted part of the latter just as Elmley and Hartly Island are always accepted as belonging to Sheppey. Another and perhaps a more reasonable explanation is that St. Augustine having been given permission to leave Thanet crossed to Richborough, then the natural landing-place, as the Roman road from there to Canterbury must still have been in existence at that date.

In any case the fact that there was a chapel at Richborough dedicated to the Saint points to the place being closely connected with him and there is some indication that the original structure was of pre-Conquest date.

The following description of the remains of the chapel and their significance is by Mr. A. W. Clapham, F.S.A.

The remains of the chapel of St. Augustine are of so fragmentary a nature as to render their definite elucidation almost impossible. The conclusions, therefore, presented in the sequel must be regarded only as tentative and as a reading of evidence which is no doubt susceptible of other interpretations. The problem is further complicated by the fact that such scanty remains as exist are almost entirely those of walling below the floor-level and as such are naturally devoid of all character. Little assistance, furthermore, is to be obtained from documentary sources, which, beyond providing evidence of the continuous existence of the chapel from the close of the twelfth to the beginning of the seventeenth century, are singularly unproductive and give no indication of the period of the first foundation.

The chapel in its final form consisted of a chancel (20 ft. 9 in. by 15 ft. 6 in.) terminating in an apse, a nave (37 ft. by 23 ft. 6 in. approximately), and two western annexes. Within the north and south walls of the chancel rise two lengths of walling at a higher level and with much shallower foundations. The character of the mortar in these two walls, in the west wall of the nave, and in those of both annexes is similar and is of whitish texture mixed with numerous small pebbles; the mortar of the inner walls in the chancel is of rather darker colour than the rest. The main outer walls of the chancel and apse are built with yellow mortar such as is commonly used in twelfth-century work, and there are certain additions and alterations to the nave built in very shelly mortar of quite a different type (pls. XII, fig. I and XLVII).

The building materials of all the walls consist generally of large water-worn flints, re-used Roman septaria-blocks, and masses of re-used Roman masonry, paving, and brick fragments.

The evidence of the mortar indicates that there are at least three periods in the building but provides no evidence of their sequence. It may be assumed, however, that the apsidal chancel, from its general plan and from the character of the mortar, is of the twelfth century, and from this starting-point some tentative conclusions may be drawn as to the date of the other parts of the building. It may be premised that all the surviving walls of the chancel are below the original floor-level except perhaps the top course of the two inner walls, so that no evidence of relative date can be drawn from the depth of the foundations. At first sight it would appear that the two inner walls represent the bases of benches against the side walls, but this theory on closer inspection proves improbable for not only are benches of such a nature an uncommon feature in a small chancel, but between these walls and the main outer walls of the chancel, which immediately adjoin them, there is an interposed section of black earth. It should also be noted that at no point do the foundations of the outer walls underlie the much higher foundations of the inner walls.

The alternative and more probable theory is that the inner walls represent the side walls of an earlier chancel, round which the later twelfth-century chancel was built, while it was still standing. This theory receives remarkable support, almost amounting to confirmation, from the existence of a queer rebate in the twelfth-century foundations, at the springing of the apse. This rebate is more marked at the base of the wall than higher up and evidently does not represent an architectural feature of the apse. It is, however, at once and satisfactorily explained by the supposition that it represents the original north-east angle of the earlier chancel, round

which the twelfth-century chancel was built. The earlier wall itself has here been destroyed but its ghost has evidently been preserved in the later walling. If these lines be laid down on plan the resultant early chancel would measure 14 ft. by 10 ft.

As to the date of this early chancel something further may be said. The side walls were probably about 2 ft. thick and the building antedated the twelfth-century rebuilding, and both these circumstances point to a pre-Conquest date, which receives additional support from the general form of the building. Beyond this it is impossible to go, though the probabilities favour a date rather later than earlier in the period.

The character of the mortar indicates that the west wall of the main structure of the nave was of approximately the same date as the early chancel. The foundations of most of this wall remain, giving the length of the building. The original breadth is indeterminate and the lines shown on the plan are based on the assumption that it was the same width as the forebuilding. If this were so, the fragmentary remains on the north and south must represent a subsequent widening of uncertain date which overlay three earlier burials on the north as the twelfth-century extension of the chancel still overlies a similar burial.

Adjoining the nave on the west was an annexe or forebuilding of which part of the west and north sides remain. It was approximately of the same date and had on the west side a second and much smaller annexe. This second annexe was evidently an addition, as a straight joint exists between the two buildings, but the character of the mortar is identical.

The purpose of these annexes is quite uncertain but the inner may well have served as a porch and the outer possibly supported a flight of steps leading up to it.¹

The supposedly pre-Conquest chapel then consisted of a rectangular chancel (14 ft. by 10 ft.), a nave (36 ft. by 16 ft.), an inner annexe (7 ft. wide), and an outer annexe.

Probably in the twelfth century the chancel of this structure was rebuilt on an enlarged plan enveloping (as has been said) the earlier structure. Any great increase in length was negated by the immediate neighbourhood, on the east, of the edge of the slope or landslip down to the sea-level. This may also account for the square *massif* of masonry at the north-east angle of the building, a feature probably repeated at the south-east angle, but now destroyed. Whether these square angles were carried up is uncertain, though this was probably the case, as there are remains of

¹ Foundations of similar flights of steps in front of the narthex were found at St. Augustine's Abbey, Canterbury.

what may have been an added diagonal buttress at the north-east angle. The foundations of the apse are somewhat irregular but would appear to indicate that the structure itself was of the same span as the rebuilt chancel. A small portion of original plastered facing remained on the external face of the apse.

The nave, though not entirely rebuilt, shows evidence of alterations at a later medieval date; these added or rebuilt portions include a large buttress on the north side, a stretch of walling on the south side, and the north and part of south ends of the west wall.

SMALL OBJECTS IN METAL, BONE, ETC.

(Pls. XVI-XXV)

1. Bronze brooch formed of a single piece of wire, with solid catch-plate and flattened bow. The spring is bilateral, the chord passing under the head. Found in the top soil.

This type is developed from the normal La Tène III fibula. Usually the profile of the bow is curved, but in some later examples it tends to become angular. This type is common on South British, Gaulish, and Rhenish sites. Its comparative rarity on Roman sites in the north of Britain and parallels from the continent suggest that it did not survive long into the second century. It would be dangerous to lay too much stress on the three examples from Neckarburken East Fort and on those from Zugmantel, as neither site is free from earlier relics.

The following are among the examples recorded: Glastonbury Lake Village (several, e.g. *Glast. Lake Vill.*, E 20, pl. XL. Occupation ended before the Roman conquest. See also the list of parallels there quoted (i, 193), none of which comes from the north of England). Trelan Bahow (form of foot uncertain, in a grave dated c. A.D. 50, *Arch.* lxi, 330); Silchester (at least sixteen in Reading Museum. Occupation began at the end of the first century B.C.); Hambleton (thirty-seven examples. Occupation began c. A.D. 50, *Arch.* lxxi, 190, fig. 20); Rushmore British Village (Pitt-Rivers *Excavations*, i, pl. XII, 4); Rotherley British Village (*ibid.* ii, pl. XCIX, 8 and C, 11); Newstead (one example A.D. 80-180, *Newstead*, pl. LXXXV, 1); there are two local examples in the Carlisle Museum, which are unlikely to date before A.D. 80 (*Trans. Cumb. & Westm. Ant. & Arch. Soc.*, N.S. xix, 8, no. 6); Hofheim (A.D. 39-79, Ritterling, *Hofheim*, pl. IX, 181-4); Stockstadt (occupied under Domitian A.D. 84-96, *O. R. L.* xxxiii, pl. VII, 1-3 and 10-13); Osterburken (occupied just before A.D. 100, *O. R. L.* ii, pl. VI, 3); Zugmantel (first camp erected A.D. 121, *O. R. L.*

xxxii, pl. ix, 13-16 and 20-3); Neckarburken East Fort (praetorium erected in 145-6, *O. R. L.* ix, p. 29, 2).

2. Bronze brooch with hinged pin and solid catch-plate with terminal moulding. The bow is decorated with a raised central rib. Top soil, site I.

To produce an exactly dated parallel is difficult, but many varieties of this type with ribbed decoration on the bow occur in the middle of the first century and continue into the Flavian period. Examples may be quoted from Wroxeter, where the type appears to date from 75-100 (*Wroxeter*, 1914, p. 22, pl. xv, 3); Hofheim (39-79, Ritterling, *Hofheim*, pl. x, 227-32); and Neuss, where the type is ascribed to the early period (*Bonn. Jahrb.*, Heft 111-12, pl. xxiv, 19).

3. Bronze brooch with slightly curved bow. The catch-plate is pierced with two openings and shows some traces of a moulded terminal. The catch which holds the chord of the spring is cast in one piece with the head, and is extended to form a raised moulding along the upper part of the bow. The missing bilateral spring was protected by two wings. Top soil.

Typologically this fibula should be rather earlier than the similar examples from Poltross Burn (unstratified, but after 120, *Trans. Cumb. & Westm. Ant. & Arch. Soc.*, N.S. xi, 440, fig. 20. 4); and Newstead (lost about 150 or later, *Newstead*, pl. LXXXV, 4), both of which have the complete semi-cylindrical spring cover.

Two similar fibulae were found, each with a semi-cylindrical spring cover and a single opening in the catch-plate. They closely resemble those from Poltross Burn and Newstead, quoted above. Low level, west of site III (no dating significance), and top soil.

A fourth example with a solid catch-plate was also discovered. Top soil.

4. Bronze brooch with curved moulded bow and solid catch-plate. The bilateral spring of apparently twelve coils is protected by a semi-cylindrical cover, and the chord is caught up by a loop. This probably dates from about 100. Site I.

5. Bronze brooch with hinged pin, solid catch-plate, and foot ending in a knob. This is a heavy and degraded example of type 3 and may well date as late as 150-200. Top soil.

6. Heavy bronze penannular brooch, of which the upper side is moulded and the other flat. The terminals ending in small crescents are an unusual feature. The coarse bronze pin, of poor workmanship, is probably not original. No parallel can be found recorded. Top soil, site III.

7. Penannular brooch formed out of a flat strip of bronze, the ends of which are turned over to form terminals. The pin is miss-

ing. The upper side is decorated with an incised pattern. Top soil.

Fibulae of the same type but with different incised patterns occurred at Wroxeter (in a stratified deposit dated 80-120, *Wroxeter*, 1914, p. 26, pl. xvi, 14), and Saalburg (Jacobi, p. 509, fig. 82, 1), but it is hardly safe to adduce these as evidence for the date of the Richborough example.

8. Small bronze penannular brooch of round section, with flat upstanding terminals, decorated with incised lines. No parallel can be found recorded. Top soil.

9. Circular bronze disc brooch. The decoration consists of concentric mouldings with a raised circle in the centre. This contains some decayed brown matter, evidently remains of the conical enamel with which this type of fibula is usually finished. The spring and pin are missing. Top soil.

These fibulae are not uncommon on Roman sites in Britain. Gilt examples from London and Faversham have been illustrated (*Brit. Mus. Guide to Roman Britain*, p. 61, fig. 76). One was found at Wroxeter (*Wroxeter*, 1912, p. 23, fig. 9. 1, where references to several others are given). A more elaborate example came from the Saxon cemetery at Long Wittenham (grave 129, *Arch.* xxxix, 138, pl. xi, 1), and that from Warwick was probably associated with Saxon relics (*Antiq. Journ.* v, 269, pl. xxix, 2). The two last examples have been adduced as evidence of the late date of the type in this country, but it should not be overlooked that they may be Roman objects re-used by the Saxons, especially in view of the fact that there are examples from Zugmantel (abandoned 260, *O. R. L.* xxxii, p. 82, 91, pl. x, 26) and Regensburg (Lamprecht, pl. iv, 7 ascribed to 230-50).¹ A very similar type which Lamprecht (*loc. cit.*) cites as its progenitor is found at Hofheim (Ritterling, *Hofheim*, pl. x, 253-4).

10. Flat pelta-shaped bronze brooch, with pierced decoration and elongated catch-plate. The bilateral spring, of which only fragments remain, was held by a projecting bronze loop. Top soil.

The elongated catch-plate seems to belong to the late second and third centuries, and this type of brooch probably dates from the earlier part of that period. It is most common on the German Limes. Among the sites where examples occur are Osterburken (associated with a coin of Commodus 180-192, *O. R. L.* ii, pl. vi, 10); Alkhofen (destroyed under Marcus Aurelius 161-180, *ibid.*, p. 33); Stockstadt (*O. R. L.* xxxiii, pl. vii, 29); Zugmantel (*O. R. L.* xxxii, pl. x, 15); and Saalburg (Jacobi, pl. li, 6).

¹ The reference is to Heinrich Lamprecht, *Aufdeckung eines Römischen Friedhofes zu Regensburg*, 1904.

11. Bronze brooch with enclosed spring and flat catch-plate. The bow is divided into two arms, each decorated with a raised rib. The foot is imperfect. Top soil.

This type occurs on the Limes and seems to date about 180-260. See no. 13 below.

12. Bronze brooch similar to the last. Below the junction of the two arms the bow is ornamented with two transverse mouldings which typologically suggests a slight advance in date on the last. Top soil. See no. 13 below.

13. Bronze brooch. The flat head, decorated with incised circles, is finished with a moulded knob. The bow is divided into three arms, below the junction of which are two transverse mouldings as in the last example. The spring, which is missing, was held by a projection from the underside of the head. Top soil.

A second example of this type was also found. Top soil.

Brooches 11 to 13 with a divided bow are uncommon on Roman sites in this country. Three have been recorded from Corbridge, where they were attributed to the late second and early third centuries (*Arch. Ael.* iii, Ser. v, 402, fig. 19; cp. nos. 11 and 12, and vii, 184, figs. 22 and 23; cp. no. 13). Other examples have been found in the north, but none of them seems to have come from a stratified deposit. The four Richborough examples all came from the top soil, where the greater part of the finds date from the late third and fourth centuries. Dated German parallels suggest an earlier period. They occur among other places at the following forts, all of which were abandoned by 260: Niederberg (*O. R. L.* xii, pl. vii, 5); Pfünz (*O. R. L.* xiv, pl. xii, 78); Stockstadt (*O. R. L.* xxxiii, pl. vii, 9); Zugmantel (*O. R. L.* xxxii, pl. ix, 47-55, and pl. xxi, 26 and 28); Feldberg (*O. R. L.* xxv, pl. vi, 33); Osterburken (*O. R. L.* ii, pl. vi, 26); Saalburg (Jacobi, pl. 1, 5, 8, 12-16, and p. 506, fig. 81. 6 and 7).

14. Bronze crossbow brooch. The edges of the foot and of the lower part of the bow are decorated with triangular cuts. The hinged pin is missing. This is a heavy specimen of the early type of crossbow fibula. Top soil.

A close parallel may be quoted from Poltross Burn (*Trans. Cumb. & Westm. Ant. & Arch. Soc.*, N.S. xi, fig. 20. 5; third level, c. 270-330).

Another brooch, very similar but with the head missing, was also found. See no. 20 below.

15. Bronze crossbow brooch. In this example the knobbed terminals to the head and arms are already beginning to develop. Top soil.

Parallels may be quoted from Poltross Burn (*Trans. Cumb. &*

Westm. Ant. & Arch. Soc., N.S. xi, fig. 20. 6; third level, c. 270–330) and from a grave at Regensburg (Lamprecht, pl. iv, 10, ascribed to 260–80). See no. 20 below.

16. Bronze crossbow brooch. This is a heavy fibula with the knobbed terminals of the head and arms well developed. Top soil. See no. 20 below.

17. Arms and bow of a heavy bronze crossbow brooch. The foot, which was a separate casting riveted to the bow, is missing. Top soil.

This is the fourth-century type and may be compared with the gold fibula from Segontium (Wheeler, *Segontium*, 130). See no. 20 below.

18. Head and bow of a heavy bronze crossbow brooch. The three holes are for the attachment of an ornamented boss which must have been unusually elaborate. The missing foot was attached to the bow as in the last example. Top soil. See no. 20 below.

19. Bronze crossbow brooch. Top soil, north-west of site I, 3 ft. down.

The form of the knobbed terminals and the cusped decoration of the foot belong to a type of fibula found in Gaul at the end of the Roman period and probably surviving into the Frankish era. Many of these have the pin fixed by a screw-in terminal (see no. 20). The Richborough example may be compared with that from Barrington (Fox, *Archaeology of the Cambridge Region*, pl. xxii, 4). A dated example with the screw-in terminal was found near Poitiers, with a hoard of coins ranging from Valentinian I to Arcadius, 361–408 (*Bonn. Jahrb.*, Heft 123, p. 153, fig. 14). See no. 20 below.

20. Bronze screw-in terminal, belonging to a brooch similar to the last. Top soil.

This terminal was screwed into one arm of the fibula, the point passing through a loop at the end of the pin. The point of the pin was held in a socket in the foot, and could only be released by unscrewing and detaching the terminal. This method of attachment is treated in the article above quoted (*Bonn. Jahrb.*, Heft 123). The screw turns left-handed. No other example seems to have been recorded from this country. The gold brooches found in the tomb of Childeric (*obit* 481, *ibid.*, p. 151) are variations of the same type.

An early type of crossbow brooch, in which the boss on the head is sometimes lacking, is found in many forts of the German Limes. No. 14 is a heavy example of this type. These fibulae first appear about 200. One was found at Saalburg in a deposit, sealed in the time of Caracalla, 212–217 (*O. R. L.* xxxii, p. 76). At Regensburg two occurred in graves ascribed to the period 170–200 (Lam-

precht, pl. iv, 2 and 3). Other examples dating before 260 were found at Saalburg (Jacobi, pl. XLIX, 3 and 4), Osterburken (*O. R. L.* ii, pl. vi, 22), Weissenburg (*O. R. L.* xxvi, pl. vi, 9), Faimingen (*O. R. L.* xxxv, pl. vi, 1), Zugmantel (*O. R. L.* xxxii, pl. ix, 59-65, and xxi, 42 and p. 70, fig. 6. 3), Holzhausen (*O. R. L.* xxii, pl. vii, 7 and 8), and Pfünz (*O. R. L.* xiv, pl. xii, 82-3). About 250 a heavier type with knobbed terminals began to be evolved. Nos. 15 and 16 are transitional examples, and in addition to those quoted above another may be cited from Pfünz (*O. R. L.* xiv, pl. xii, 84). The heavy type with knobbed terminals was in vogue in the fourth century, but there is an example from a Cologne grave illustrated by Poppelreuter and Hagen, and by them ascribed to the third century (*Bonn. Jahrb.*, Heft 114-15, pl. xxv, grave 62, and p. 367). Other examples of the same type may be cited from graves at Regensburg (Lamprecht, pl. iv, 11, with a coin of Licinius, 271-3, 12, with coins 320-30, and 14, with Theodosian coins *c.* 390) and another at Vermand (Baldwin Brown, *Arts in Early England*, iv, pl. cXLVIII, *c.* 400). They are common on some sites in this country. Nos. 17 and 18 are developments of this type, but no. 19 is a variant which seems to be very rare in Britain and survives well into the fifth century. All the Richborough examples of these fibulae were found in the top soil, which suggests a date after about 250-75.

21. Bone needle. Site III.

Several of this type have been found. The flattened expanding head is a not uncommon feature, which may be seen on several examples in the Colchester Museum. The same type is illustrated from Newstead (*Newstead*, pl. xcii, 22).

22. Bone pin. Top soil.

The head is roughly carved to represent a human face. Pins with the heads thus decorated often occur on Roman sites. A fine example in ivory was found at Wroxeter (*Wroxeter*, 1914, pl. xxii, fig. 2).

23. Bone pin. Top soil.

Pins of this type are very common at Richborough and on other sites.

24. Pair of bronze tweezers. Site III.

The butt end is finished as a probe. Probably a surgical instrument.

25. Bronze tweezers. Top soil, west of site III.

26. Bronze pin. Site III.

Several other similar examples were found.

27. Bronze needle. Site III.

A common type.

28. Bronze needle with two eyes. Top soil.

The thick head has raised flanges on each side. The purpose of the two eyes may be to prevent the thread from slipping. Compare that from Wroxeter with two eyes at right angles (*Wroxeter*, 1914, p. 26, pl. xvii, 20).

29. Bronze needle of crude pattern. Top soil.

A common type.

30. Bronze pin with spherical head and an engraved spiral round the neck. Site III.

31. Bone ornamented with incised dot-and-circle design and pierced at the larger end. Top soil.

Similar bones were found at Stockstadt, where the following description is given: 'Two metatarsal bones, apparently of a pig, prepared for some unknown use. One end is pierced, in the larger with three, in the smaller with eleven holes' (*O. R. L.* xxxiii, p. 125, 4, and pl. viii, 40 and 56). It is possible that they may be implements similar to those found in Glastonbury Lake Village (types E and F, *Glast. Lake Vill.* ii, 424-7) which were thought to have been used as bobbins.

32. Bronze weight. Top soil.

The right-hand sign represents *ὀνυκία* and the left *semis* or *semissis*, that is to say six ounces. It weighs 163.3 grammes, which is extraordinarily close to the original standard 163.72 grammes. A Roman pound weighed 327.45 grammes. In almost every case the loss from corrosion has been very much greater.

This is a common Roman form. Cf. *C. I. L.* xiii, 10030, 76, and Hettner, *Illustrierter Führer durch das Provinzialmuseum in Trier*, p. 91. Two, each of a pound, are illustrated, one from Neath and the other from Mainz (*Proc. Soc. Ant.* xx, 189). Another has recently been found at Alchester (*Antiq. Journ.* vii, 182, fig. 11).

33. Openwork bronze plate of cruciform shape. At the back is a stud for attachment. Site III in association with late pottery. Probably an ornament for leather.

34. Bronze nail-cleaner. Top soil, site III.

The front is decorated with an engraved monster. Usually the butt end is finished with a ring for suspension, but another example with the split butt and rivet for attachment may be quoted from Traprain Law (second level, Antonine, *Proc. Soc. Ant. Scot.* xlix, 174, fig. 26. 1). See also no. 35.

35. Incomplete object, similar to no. 34. The front is engraved with geometrical designs. Top soil.

36. Iron clasp-knife with a handle of carved bone. The hinge is held by a bronze mounting. Top soil.

Clasp-knives with bone or ivory handles are not uncommon on

Roman sites. The handles are often very elaborate like that from Wroxeter (*Wroxeter*, 1913, pl. x).

37. Spoon of white metal. Top soil.

The mandolin-shaped bowl is not uncommon in Roman spoons. One found at Traprain Law (second level, third or more probably fourth century, *Proc. Soc. Ant. Scot.* 1, 132, fig. 41) and others from Cologne (*Germania*, xi, 39, late third century) and the early Christian examples in the British Museum (*Arch.* liii, 113) suggest that this may be a late Roman type.

38. Bronze clasp or button with a rectangular pierced head. Usually the foot is also pierced so that it can be sewn to the material, but in this example a loop projects from the back of the foot. Top soil.

Among other places these clasps have been found at Richborough (*Richborough*, I, pl. xv, 28), Newstead (*Newstead*, pl. lxxv, 7 and 8), Wroxeter (*Wroxeter*, 1912, pl. x, 4, and 1913, fig. 5, 15 and 16), and Saalburg (Jacobi, pl. liii, 12 and 13).

39. Bronze lamp-hook. Site III, room 3. Low level under second floor. A.D. 75-100.

The use of these hooks is discussed by Romilly Allen (*Proc. Soc. Ant. Scot.* xxii, figs. 9 and 17).

40. Part of a bronze bracelet. See no. 51. Top soil.

41. Two square plates of bronze with circular bosses fastened together by five rivets. The missing rivets in the corners probably had ornamental conical heads like the example in the centre. Site III.

Single plates of bronze, with similar bosses for the strengthening and ornamentation of the belt, were found at Newstead (*Newstead*, pl. xxv, 42 and 44). The Richborough plates are of uncertain use.

42. Bronze buckle. The tongue was of iron. Top soil, site III.

43. Bone comb. The handle is strengthened by two plates decorated with concentric circles and triangular cuts. The whole is held together with bronze rivets. Top soil.

That this type may survive into the Saxon period is shown by a similar example from an early Anglian cremation burial at Malton, Yorkshire (Baldwin Brown, *Arts in Early England*, iv, 391, pl. lxxxv).

44. Bronze fitting. Probably a belt mounting. Site III.

45. Bronze loop-handle for a box or drawer. The ends are turned back and finished as birds' heads. The split pins, by which the handle was attached, were found in place. Top soil.

46. Bronze tongue-shaped strap-end. The rivet attaching it to the strap was held by a bronze plate at the back. Top soil. See nos. 48 and 49 below.

47. Bronze tongue-shaped strap-end, ornamented with two openwork wings. The back of this example shows that it originally had a split butt for attachment to the leather strap. Top soil. See no. 49 below.

48. Bronze tongue-shaped strap-end. The example seems originally to have had a split butt for the reception of the strap (see no. 49), but the back part of this was broken off and replaced by a separate sheet of bronze which still remains in place. The front is decorated in the chip-carving technique, a style common during the late Roman and migration periods. Another object from Richborough showing this technique is illustrated (*Richborough, I*, pl. XIII, 11). Top soil. See no. 49 below.

49. Bronze tongue-shaped strap-end. Top soil. In this example the split butt end in which the strap was fixed remains intact. This seems to have been the normal method of attachment of these terminals.

The tongue-shaped strap-end occurs in early Saxon graves in this country. Baldwin Brown illustrates examples from Croydon and elsewhere (*Arts in Early England*, iv, pl. CLII, 1 and 12). It is also found in the cremation cemeteries of Schleswig-Holstein (*ibid.*, pl. CXLIX, 6, from Hammoor B, and pl. CLIII, 1, from Quelkhorn). Mr. Leeds states that there is an example from the early cemetery at Borgstedt in Kiel Museum. One was recently discovered among the treasure of Traprain, and was thought to belong to the pirates responsible for the deposit of that hoard early in the fifth century (Curle, *Treasure of Traprain*, no. 149, pl. xxxii). They occur on Roman sites in the latest period, when barbarian influences were already strong. Examples may be quoted from graves at Sablonnière (*Album Caranda*, pl. J, 29), Vermand (Pilloy, *Sépultures dans l'Aisne*, ii, pls. xvi, 3 a, and xxi, 1 b, and *Tombeau militaire*, no. 3). Another was found at Wiesbaden (*O. R. L.* xxxi, pl. x, 38, occupation continued into the fourth century). They date from the fourth and fifth centuries.

50. Small bronze strap-end. Top soil.

Sculptured reliefs such as the memorial stone of Gnaeus Musius at Mainz (*Newstead*, p. 175, fig. 16) show an alternative method of finishing the free end of the belt. Instead of ending in a single metal tab, the terminal of the strap was cut into several small strips, to each of which was fastened a metal terminal (Ritterling, *Hofheim*, p. 152, 15). Examples of these terminals are illustrated from Hofheim (Ritterling, *Hofheim*, pl. xi, 56-7 and 66), Stockstadt (*O. R. L.* xxxiii, pl. vii, 31 and 33), and Zugmantel (*O. R. L.* xxxii, pl. x, 76). Ritterling is of the opinion that these terminals are not found later than 150.

51. Incomplete bronze bracelet. Top soil, west of site III.

The hooked end fastened into a loop, as no. 59. The bracelet has at some time been flattened. Several fragments of similar bracelets were found in the top soil, suggesting a late date. See also nos. 40 and 63.

52. Ornamental bronze plate of which the four angles are pierced for rivets. Top soil.

Two pairs of these objects were found at Maryport. It was suggested that they were ornaments for a box (*Trans. Cumb. & Westm. Ant. Arch. Soc.*, N.S. xv, 169, pl. xi d). Another pair was found at Vermand in a grave, evidently that of a lady of rank, c. 400 (Baldwin Brown, *Arts in Early England*, iv, pl. cXLVIII).

53. Bronze scabbard chape with openwork ornament. Top soil.

Usually the Roman chape is shallower, but this example may be compared with those from Corbridge (*Arch. Ael.*, Ser. III, vii, 188, fig. 36), Saalburg (Jacobi, pl. lv, 4), and Zugmantel (*O. R. L.* xxxii, pl. xi, 8, and xx, 72).

54. Bronze object with rivet holes at each end. The central bar is slightly raised. Top soil.

It may have formed part of the binding of a leather scabbard.

55. Openwork bronze plate. Top soil.

The smooth flat back suggests that it was sewn on to a leather or material foundation.

Similar plates were found at Pfünz (*O. R. L.* xiv, pl. XIII, 46 and 47) and Faimingen (*O. R. L.* xxxv, pl. VIII, 13). A similar but longer example was discovered at Wroxeter, where its use as a scabbard binding is suggested (*Wroxeter*, 1914, p. 31, pl. XXI, 1).

56. Cross-bar and suspension handle of a small pair of bronze scales. Top soil.

57. Bronze martingale with three loops for uniting straps. The central ornament suggests a poor representation of a bird's head. Top soil.

These martingales are not uncommon on Roman sites. Another example from Richborough has been illustrated (*Richborough*, I, p. 47, pl. xv, 29, where references are given).

58. Small bronze key. The handle ends in a loop for attachment. Top soil.

59. Bronze bracelet decorated with diagonal cuts. These may be in imitation of the twisted wire bracelets (as no. 60). The fastening is a variation of the hook-and-eye type which is usual in the Roman period (*Brit. Mus. Guide to Roman Britain*, p. 67). Two of this type and no. 62 were found together in the top soil.

60. Bracelet made of three strands of bronze wire twisted together. The fastening is missing. Top soil.

61. Thin bronze bracelet decorated with a raised undulating line. It was originally annular, but has been broken. Top soil.

62. Annular bronze bracelet, decorated with transverse cuts, giving the appearance of beading. It was found with no. 59. Top soil.

63. Strip of decorated bronze. The ends have been riveted together to form a bracelet. Top soil.

64. Circular plate of bronze with pierced decoration. In the centre of the back is a projecting stud for attachment to leather. Top soil, site III.

Similar plates were found at Zugmantel, where they are classed among the appurtenances of the girdle (*O. R. L.* xxxii, p. 88, 19, pl. XII, 6). Others are illustrated from Osterburken (*O. R. L.* ii, pl. VI, 35) and Pfünz (*O. R. L.* xiv, pl. XIII, 52). These openwork discs often bear inscriptions, e.g. that from Corbridge (*Arch. Ael.*, Ser. III, vii, 178), and in some cases the central motive is an eagle.

65. A bronze statuette found in the bottom of the filling of the middle ditch. See p. 22.

(The following account is by Mr. F. N. Pryce, F.S.A.)

A tiny example of the well-known *genius familiaris*, standing $4\frac{1}{8}$ in. (= 0.105 m.) high and in its present state weighing less than 7 oz. The surface has suffered considerably, and the right hand, the attribute held in the left, and the toes of both feet are broken away, apparently deliberately.

A Roman citizen stands upright, turning slightly to his right; his right arm is extended, pouring a libation from a patera. He is beardless, with hair cut in a fringe, and is veiled in the *toga praetexta*, of which the component folds are indicated in the customary pattern. The garment, a single segmental piece of cloth 18 ft. long at the chord, was an elaborate affair to adjust. The straight edge, drawn up in the hand into a mass of folds, was laid over the left shoulder; one end in front fell over the left arm and almost trailed on the ground; the other end was placed over the right shoulder, so that the back was covered, and drawn under the right arm across the breast up to the left shoulder. The remaining breadth of the material was then gathered in a semicircular sweep round the front from right knee to left shoulder, forming the *sinus*; the back of this normally rested on the shoulder, but at the moment of prayer was drawn over the head, to shield eyes and ears from any ill-omened sight and sound.

Such is the traditional type of the Roman paterfamilias, as he was depicted on countless *lararia* throughout the Empire in his capacity as the guardian genius of the home. The Roman house-

hold shrine is too well known from Pompeii and elsewhere to require detailed description here ; a little niche with tiny columns and gable like a miniature temple ; in the centre, in painting, clay, or bronze, three little figures—the master of the house sacrificing, as we have described, on either side a dancing Lar, and underneath a snake. Of such a group our little bronze was once the central feature ; another year's campaign may give back to us his attendant Lares. Of pure classical style, it was no doubt made in Italy, and can hardly be much later than A. D. 200, but how much earlier it is impossible to say.

The one doubtful point is the restoration of the attribute held in the left hand. The type has two ordinary variants, one holding a cornucopie, the other an incense-box (*acerra*). The pose of the arm in our example excludes the cornucopie, which from its weight would be held closer to the body ; on the other hand it is exactly the right position for the *acerra*. But the *acerra* should rest on the open hand, whereas on the bronze the hand appears closed around a circular stalk. This suggests a much rarer variant, in which the left hand holds a short round rod ; there is a good example in the British Museum, found at Cricklade. The object is generally described as a roll of parchment, which seems unfounded. An attribute with some ritual purpose is called for, and the Cricklade example shows a marked curve at its upper end. Probably it represents an augur's staff or *lituus*.

66. Object of iron, consisting of two double iron arms, hinged together. A ring is hinged on to the outer end of each arm. Found 2 ft. 6 in. down with a number of bones.

It has been suggested that this may have been a pair of handcuffs or fetters. No known Roman example of this type can be quoted.

67. Small pair of iron shears. Top soil.

Similar shears were found at Saalburg (Jacobi, pl. xxxv, 12 and 14) and Newstead (*Newstead*, p. 291, and pl. LXVIII, 5), where it is suggested that they were used in connexion with weaving.

68. Iron key with large oval handle. Site III.

A similar example attached to a bracelet has been figured (Brit. Mus. *Guide to Roman Britain*, fig. 86). There are also similar examples in the Guildhall and Canterbury Museums.

69. Iron key. The handle ends in a loop for suspension. Site III. This type of key was common during the Roman period.

70. Iron axe-head. Top soil.

The extension of the head to form a long socket for hafting is an unusual feature in Roman axes. It should be compared with others showing the same feature from the Saalburg (Jacobi, pl. xxxIII, 1 and 2) and Gross Krotzenburg (*O. R. L.* xx, pl. v, 28).

71. Iron axe-head. Top soil.

A common Roman type. See no. 72.

72. Iron axe-head. Top soil. A common Roman type.

These represent two of the commonest types of Roman axes. Parallels may be quoted from Newstead (*Newstead*, pl. LXI, 1 and 4), Zugmantel (*O. R. L.* xxxii, pl. xvi, 7), Wiesbaden (*O. R. L.* xxxi, pl. xi, 41 and 42), Gross Krotzenburg (*O. R. L.* xx, pl. v, 18), and other Roman forts in this country and abroad.

73. Iron axe-head. Top soil.

The butt end is finished with a square head as though it were intended to be used as a hammer. This is an uncommon type, but a similar example from Cannstatt may be quoted (*O. R. L.* xxviii, pl. ix, 7).

74. Iron knife. A common type. Top soil.

A parallel may be quoted from Saalburg (Jacobi, pl. xxxvii, 4).

75. Side of a white glass cup or beaker. Top soil, site III.

The decoration consists of an upper band of oval depressions, the intervening spandrels being filled with cross-hatched faceting and a lower band of vertical cannelures. Kisa (*Das Glas in Alerturne*, ii, 635) shows how this decoration was made with a heated, blunt metal instrument.

76. Two lobes of transparent green glass. These were obtained by allowing molten glass to drop over hollow knobs projecting from the wall of the vessel. In one case the knob has run and formed a pouch. Top soil, west of site III.

Kisa (*Das Glas in Alerturne*, ii, 486, fig. 143) cites a glass vessel from the Musée St. Germain, where a similar decorative effect is obtained by allowing molten glass to drop over small solid knobs projecting from the side of the vessel, which is ascribed to the sixth century. Superficially the Richborough lobes resemble the claw-glasses which are found in Saxon graves in southern England (Baldwin Brown, *Arts in Early England*, iv, 483, pls. cxxiii and cxxiv). No. 76 A shows one of these vessels, which are usually ascribed to the sixth to eighth century. In these claw-glasses the process of manufacture was to pass the lobe or pouch through an opening in the wall of the vessel. Kisa, following Pilloy, suggests that all these trick glasses, for the manufacture of which considerable technical skill would be needed, were produced by descendants of the glass-workers of the later Empire, the makers of the intricate hour-glasses (*Album Caranda*, 45. 1). The Richborough lobes certainly belong to the same tradition, but it is impossible to date them accurately.

77. Small plate of white glass. Top soil.

The resemblance to Samian forms of the Antonine period or later affords a clue to the date.

78. Small bronze buckle. The leather strap was fixed between the double bronze plate by a rivet. Top soil.

79. Flat bone die, measuring 8 mm. by 7.5 mm. by 4.5 mm. The 1 and 6 are on the largest sides. Top soil.

Dice are common on Roman sites. One with what is thought to have been a dice-cup was found at Kenchester (*J.R.S.* xv, pl. xxxiv).

80. Female head of thin gold with composition core. Top soil.

The method of hair-dressing and the use of the net are interesting. Probably late in date.

81. Bronze stud. The surface is inlaid with small circles of glass or enamel. Top soil.

Several examples from Newstead are illustrated (*Newstead*, pl. LXXXIX).

82. Bronze hinged brooch. The central plate is inlaid with enamel. Pit 26, which contained articles from the first century up to 300.

The form suggests that it should be dated to the Antonine period or rather later. Similar examples from Belgium are figured by Bequet (*Annales de la Société Archéologique de Namur*, xxiv, 237, pl. 1, 8 and 9), and others from Charterhouse on Mendip may be seen in the Bristol Museum.

POTTERY

THE DECORATED SAMIAN

(Plates xxvi-xxviii)

Without taking into account the numerous rims, bases, etc., upwards of nine hundred fragments of decorated Samian vessels were discovered during the period covered by this report. One piece of a Gaulish crater must be a relic of the earliest years of the occupation, and among the 135 fragments of form 29 some were undoubtedly of the time of Claudius and Nero, although the majority of this type was of Flavian date. Form 30 was represented by only thirty-three fragments, and of these nine were probably pre-Flavian, five Flavian, five early second century, and fourteen of later date. Specimens of form 37 of first-century date numbered 309, of the early second century 129, and of the Hadrian-Antonine period 352. There were five pieces of form 67. Most of the vessels were products of the South Gaulish and Lezoux potteries, the East Gaulish and German only being represented by some seventy or eighty examples.

A large amount of this ware, including more than half of the

fragments of form 29, was found in clearing the top soil, and although of little or no value for dating purposes affords striking testimony to the disturbed nature of the site. The specimens from the summer excavations of 1924-1925 were mostly from below the 3-ft. level, and a classification of these showed that, although the best represented period was the late first and early second century, there was practically no difference in the number of examples that could be assigned to before and after A. D. 120. A preponderance of pre-Hadrianic types was noticed in 1922-1923, and that this should not have been maintained may be accounted for by the fact that in the previous excavations the whole area dealt with was almost entirely dug out to the natural soil, whereas in 1924-1925 the lowest levels were often only tested in places, and nearly the whole of the early strata to the north and east of the platform and under the chapel still await investigation.

Pls. xxvi, no. 2, and xxvii, no. 1. Form 11. Found in clearing the top soil west of site I.

Dull red glaze; indifferent workmanship. Rim and portion of the decorated wall.

In this type of crater the widely everted rim is followed by an almost hemispherical body which terminates in a pedestalled foot-stand. This form was produced in the early periods of both La Graufesenque (Déch. i, pl. 1, 11, VOLVS) and Lezoux (Déch. i, fig. 99, Necropolis of Chassagne). It is a direct copy of one of the three prevailing varieties of Italian crater (cf. Chase, *Cat. of Arretine Pottery, Boston*, figs. 132, 133, M.P.]EREN BARGAT; Oswald & Pryce, ii, 3, ATEIVS).

The upper limit of the decoration alone remains, in the form of repeated multifid leaves. Immediately above the leaves and demarcating the upper limit of the decorated zone are two horizontal ridges. Similar ridges with intervening grooves are seen on Augustan and Italic craters at Haltern (Loeschcke, xvii, 3; Oswald & Pryce, ii, 1, CRESTVS ATEIVS and EVHODVS) and on the ATEIVS vessel at Mainz (Oswald & Pryce, ii, 3). They are also present on a Gaulish crater, found in Angel Court, London (London Museum). Internally, at a point slightly higher than the external ridging, is a horizontal fluting, as in South Gaulish craters at Hofheim (Ritterling, *Hofheim*, xxxii, 16) and in the London and Guildhall Museums. Italian or Arretine examples of the crater with everted rim have been found in the Augustan period at Haltern (Loeschcke, p. 157; Curle, *T.-S.*, fig. 5).

Gaulish examples of the Tiberio-Claudian period have been found at Neuss (Curle, *Proc. Soc. Ant. Scot.*, li, p. 143, fig. 10) and Bregenz (Knorr, 1919, pls. 2 and 3).

In the Claudian period at Hofheim five examples have been found (Ritterling, *Hofheim*, abb. 46. 1, 2; abb. 47), but the type is already rare on this site.

In Britain, two examples have been found in London (Guildhall Mus. and London Mus.), one at Colchester (Walters, *B. M. Cat.*, M. 1001), and one at Richborough. This vessel has not been recorded on sites which were occupied subsequent to the reign of Claudius. The stamp of the Tiberio-Claudian potter VOLVS appears to be the only mark as yet recorded on the Gaulish crater.

Pl. xxvii, no. 2. Form 29. Found in top soil over main east and west road.

Dull glaze, good workmanship. Lower frieze: *Rinceau* decoration; the stalks of the scroll ending in polygonal, many-pointed leaves. The bifurcations of the stalks are masked by bifid 'tendrils-unions', composed of a small bifid leaf and a single bead. A closely similar leaf and tendril-union occur on the lower frieze of a Tiberio-Claudian form 29 by BALVVS, at Wiesbaden (Knorr, 1919, 11 B). This type of leaf was used by many first-century potters from the Tiberio-Claudian (Knorr, 1919, 70 A, SCOTTIVS, 76 B, D, F, SENICIO) to the Flavian period (Atkinson, *Pompeii*, 27, VITALIS). When employed in the Flavian period the bifid tendril-union is almost always absent. This type of tendril-union is highly characteristic of the work of the earlier or pre-Flavian potters and is rarely met with on sites which were first occupied in the Flavian period (compare, however, Knorr, 1912, vi, 4, probably a survival). At Pompeii it occurs in a modified form and without the bead (Atkinson, *Pompeii*, 21, MOMMO). The dull glaze is characteristic of much early sigillata.

Period: Claudian.

Pl. xxvii, no. 3. Form 29. Found in top soil over main east and west road.

Good glaze and workmanship. Central, plain moulding bordered above and below by bead-rows. Lower frieze, divided into two zones by a wavy line. In the upper zone (1) a dog to r. (Déch. 924 GERMANVS), as also used by the pre-Flavian potters AQUITANVS and GENIALIS (Knorr, 1919, 8 B, 33) and the Claudius-Vespasian potter NIGER (Walters, *B. M. Cat.*, M. 355); (2) in a medallion, a large rosette closely resembling those used by BASSVS (Knorr, 1919, 13 M, OFBASSICO), CELADVVS (*ibid.* 21 B), and NIGER (*ibid.* 61 c). Somewhat similar rosettes enclosed in medallions occur in the Vespasianic work of MOMMO (Atkinson, *Pompeii*, 13, 14). In the lower zone are repeated arrow-heads of an early type.

Period: Claudius-Nero-Vespasian; more particularly Neronic.

Pl. xxvii, no. 5. Form 29. Found in clearing the top soil west of site I.

Poor red-brown glaze, porous red-brown paste, and generally negligent execution; probably made in a worn mould. A small part of the rim, which shows no trace of the normal rouletting, remains.

Upper frieze: panel decoration, demarcated by two repeated, raised lines which show some traces of the wavy outline usual on South Gaulish ware. A terminal rosette is seen to r.

In the panels are animals, only one of which (in the third panel) can be identified. This is the deer to r. with head turned back, as used by the South Gaulish potters, MERCATO (Déch. 859), CALVVS, OFCEN, COÉLIVS, IIVST, MEDDILLVS, PASSENVS, and SASMONOS (Knorr, 1919, 18, 22, 23, 44, 54, 62, 70).

Plain central moulding, bordered above and below by ridges, which, however, in places, show some traces of the beads normally found in this situation. The same ridging, in place of bead-rows, is seen on two Lezoux bowls, forms 29/37, in the Plicque collection. Their decorative types are early second century.

Lower frieze: interrupted arcading. In the interspace, two upright spirals and a vertical ornament with bilateral spirals and fan-shaped terminal. From near its base rise two serrated and pointed leaves of South Gaulish type. Between the vertical ornament and the arcades, the figure of a man to l. (Déch. 510), repeated. This type occurs in South Gaulish sigillata in London and Rottweil (Walters, *B. M. Cat.*, M. 523 and 557; Knorr, 1907, xii, 1, 2; xiii, 4, 5; 1912, xviii, 1). The ware is all of the late Flavian type with the exception of Knorr, xiii, 4.

The bowl has the definite carination of late Flavian examples of form 29, and its types point quite definitely to a South Gaulish origin. It belongs to much the same category as the late forms of this vessel by RANTO (Oswald & Pryce, xxviii, 12, Heddernheim, dated c. A. D. 90), the Leicester bowl (Oswald & Pryce, xxviii, 10), that by SATTO (Fölzer, vi, 4, Pfunz), and the form 29 with stamp of Ω , at Caerwent, which may date from the 'turn' of the first and second centuries, i. e. c. A. D. 90-110. Closely similar vessels, form 29/37, of Central and East Gaulish origin may be mentioned (*Corbridge Report*, 1912, fig. 24; Bushe-Fox, *Arch.* lxiv, fig. 25; Déch. i, figs. 101 and 108; Oswald & Pryce, xii, 5, 'Potter of the small medallions' of Heiligenberg; Oswald & Pryce, xviii, 1, early period of Trèves). The Heiligenberg and Trèves examples appear to be definitely of early second-century date.

Pl. xxvii, no. 8. Form 37. Found in clearing the top soil.

Good glaze and workmanship. Remains of a floral wreath or

festoon. An astragalus forms a juncture at the lower curve of the wreath. Beneath the wreath are repeated astragali and an acanthus leaf. In the concavity of the wreath or festoon are (1) conjoined dolphins, a frequent type in early second-century work, (2) a six-beaded rosette, and (3) a gladiator to l. (Déch. 611 mould, Lezoux).

This gladiator occurs on a Trajanic form 37 at Brecon, and is represented in the British Museum (Walters, *B. M. Cat.*, M. 1287, 1297, 1298, 1526). A similar wreath occurs at Brecon and Cannstatt (Knorr, 1921, iv, 14), and is in both cases dated in the Trajanic period.

A product of Central or early East Gaul. Period: Trajanic.

Pl. xxvii, no. 10. Form 37. Found in clearing the top soil.

Dark red glaze; good workmanship. Panel decoration, demarcated by bead-rows with rosettes at the junctures. In a large panel the remains of a scroll or of a large medallion, beneath which two large rosettes are depicted. In a divided panel, (1) an indeterminate object; (2) an upright leaf, somewhat similar to Déch. 1165, found on a form 37 at Lubié. Detached leaves are not uncommon in sigillata of the Antonine period at Newstead II (*Newstead*, 221, 8; 227, 3, AVENTINI.M).

Period: Hadrian-Antonine.

Pl. xxvii, no. 12. Form 37. Found in top soil over main east and west road.

Good glaze and workmanship. The remains of a scroll, the concavity of which is filled with repeated arrow-heads, a class of decoration frequently met with in the Flavian period (cf. Atkinson, *Pompeii*, 15 MOMMO, 22 MOMMO, 38, 44, 45, 46, 49; Knorr, 1912, ix, 1, 15; x, 1, 3). Beneath the scroll is a well-executed wavy line. The design is closed by a repeated leaf ornament in the form of a straight wreath. Exactly the same leaf occurs as a lower border to the design of a form 37 at Mainz, signed by M.CRESTIO (Knorr, 1919, Text-fig. 17 E), a Flavian potter. This leaf is also characteristic of the work of the early potter OF.CRESTIO (Knorr, 1919, 27, 17) whose activity dates back to the reign of Claudius, at least. Neatly formed, early foot-stand.

Period: Early Flavian.

Pl. xxviii, no. 4. Form 37. Found in clearing the top soil west of site III.

Good glaze, paste, and workmanship. (1) Figure to right (cf. Déch. 103). (2) Crown-like object in the field. (3) Lower part of a column decorated with a lattice pattern. (4) Fine wavy line, sharper and of a more zigzag character than the wavy line on South Gaulish ware of the Flavian period. (5) Straight wreath composed of

repeated bilateral leaves with serrated borders. The form of the leaves is that of a ram's horns. The junction of the leaves is marked by one or two beads. Neatly formed, early footstand.

This type of ram's-horns leaf (either with beaded or serrated borders), repeated so as to form a straight wreath, is characteristic of much of the decorated ware of the early second century. Generally, it may be assigned to the reign of Trajan with some initial and terminal overlapping. It occurs in the work of the Lezoux potter BVTRIO (Oswald & Pryce, xx, 4), who was chiefly active in Trajan's reign, but is especially characteristic of ware which, pending further investigation, may be termed of the Luxeuil type. Thus, it was used by a potter who employed the monogram GD and who was at work at the 'turn' of the first and second centuries (Brecon, form 37, Domitian-Trajan; Walters, *B. M. Cat.*, M. 1148), and by the Luxeuil potter of the style of RANTO (Oswald & Pryce, xvii, 1, and Knorr, *Rottweil*, 1907, ix, 1, Domitian-Trajan).

Many examples are figured in the British Museum Catalogue (M. 1067, 1102 as part of general decoration, 1141 as part of general decoration, 1274, 1441, 1514 wreath omitted). This type of wreath occurs plentifully in London (British Museum, London Museum, Guildhall Museum), and has been found at Colchester, Silchester, Brecon, Wroxeter (*Wroxeter*, 1914, xxiv, 7, dated early second century), Margidunum, York, and many other sites.

This horn-like leaf, occurring as a straight wreath or as a detail of the general decoration, is frequently associated with a number of objects in the field or amongst the decoration which are quite unknown in typical South Gaulish ware. The following may be mentioned: astragali with swollen central bead (cf. Fölzer, i, 3, 7, 8, 9), cornuacopiae, crown-like ornaments, bows and quivers, lyres, detached acanthus leaves, and fine wavy lines or fine bead-rows (see illustrations quoted above). The latest examples of this type of wreath occur in the Hadrianic period at Saalburg (Fölzer, ii, 30, 44). It usually occurs on ware of good paste and glaze.

Period of Richborough fragment: Domitian-Trajan.

Pl. xxviii, no. 6. Form 37. Found in the filling of the outer ditch west of site III.

Fair glaze and workmanship. Ovolo with a circular terminal. Panel decoration, demarcated by wavy lines with terminal rosettes of the beaded type. The upper part of a cruciform ornament is composed of the following elements: (a) a central, vertical, spiral ornament from which diverge two lateral spirals; (b) two bilateral, oblique, wavy lines; (c) astragali mark the points of divergence from the central stem; (d) astragali are also placed across the two lower oblique or diagonal lines.

Astragali frequently form an integral element of the cruciform ornament in ware of Luxeuil type (cf. the IOENALIS bowl in the London Museum and Walters, *B. M. Cat.*, M. 1206, 1334). The use of *two* diagonal wavy lines or bead-rows in the cruciform ornament is also characteristic of ware of this type (IOENALIS, London Museum).

The fragment is probably early East Gaulish ware of the period Trajan-Hadrian.

Pl. xxviii, no. 7. Form 37. Found in clearing the top soil west of site III.

Fair glaze and workmanship. Aberrant ovolo in the form of a continuous spiral (cf. *Wroxeter*, 1912, xiv, 9, from a deposit dated A.D. 90-120).

The spiral meander had already appeared in the Vespasian period (Atkinson, *Pompeii*, 70), but it is especially characteristic of East Gaulish sigillata of the potteries of La Madeleine (Fölzer, i, 22, 23, 25, 26, 42) and Heiligenberg (Knorr, *Rottenburg*, x, 1, style of IANVS, 2, 3). Above the 'ovolo' are three ridges, a feature frequently met with in East Gaulish fabric (cf. Oswald & Pryce, xii, 5; xvii, 4 SATTO, 5 TRIBVNVS).

Below the spiral is a straight wreath of repeated trefoil leaves, bordered above and below by bead-rows. East Gaulish ware of the period Trajan-Hadrian.

Pl. xxviii, no. 8. Top soil. Fragment of a globular vessel with a dark metallic polish or glaze, both on the exterior and interior. Good hard-baked dark-grey paste of much the same consistency as that of ordinary sigillata. Found in clearing the top soil. It is evidently a vessel of the type described by Déchelette as *à vernis métallique*, and indicates the persistence of the influence of the metal-worker upon the sigillata potters of the first half of the second century. The decoration consists of the remains of a medallion, containing a foliated object and an upright spiral bud or spike.

The following examples of this technique are given by Déchelette in his inventory of potters' marks:

BVTRIO: No. 17, frag. BV. . . . No. 25, form 67, BVTRIO.

LIBERTVS: No. 60, form 66, OF LIBERTI.

Nos. 28-9, form 64, OF LIB-TI.

PATERNVS: No. 43, form 68, PATERN FE.

PVTRIV: No. 17, form 68, PVTRIV.

Of these potters BVTRIO and LIBERTVS worked chiefly in Trajan's reign, PVTRIV in the pre-Antonine period, and PATERNVS in the Hadrian-Antonine period. Some of the latter's work, as a form 37 in the Shrewsbury Museum, is of Trajan-Hadrian date. It will be

noted that all the forms to which this technique is applied are of the cup or beaker type. Pottery of this type is rare in Britain, but a good example (form 64) from the Old Post Office site, London, is figured in *Antiq. Journ.* v, p. 437.

The date of the Richborough fragment is probably Hadrianic.

Pl. xxviii, no. 10. Form 37. Found in clearing the top soil west of site III.

Fair glaze, paste, and workmanship. Free-style decoration—animals running to left. (1) Stag, which is not illustrated in Déchelette but which bears some resemblance to the East Gaulish types produced at Eschweilerhof and Trier (Fölzer, 314, reversed, 623). (2) Boar, which is somewhat similar to Déch. 841. The design is closed by a row of repeated spirals.

Although the spiral had already appeared in the Flavian period (Atkinson, *Pompeii*, 70), it is especially common in East Gaulish ware, as produced at Heiligenberg (Forrer, xxiii, 1 and 4, CIRIVNA; xxvii, 12, IANVS; Oswald & Pryce, xii, 5, xiii, 3) and La Madeleine (Fölzer, i, 20, 22-4, 26; ii, 38, 46), and continued to occur on later East Gaulish fabric (Oelmann, *Niederbieber*, viii, 27). Beneath the spirals are two neatly-formed grooves (cf. Oswald & Pryce, xiii, 2, IANVS; xviii, 1 Trèves). Neatly formed footstand.

East Gaulish fabric of the period Hadrian-Antonine.

Pl. xxviii, no. 11. Form 37. Found west of site III, 4 ft. down.

Poor yellowish-red glaze; porous paste, negligent workmanship. Deep plain band above the ovolo. Ovolo with swollen tongue-terminal. Deep grooving above the ovolo, a feature frequently met with in East Gaulish (including German) ware. Panel decoration, demarcated by bead-rows. The vertical bead-rows terminate in rosettes (of the lobed variety) or in acanthus leaves.

Across one bead-row is placed a rosette, whilst the other has an acanthus leaf in a similar situation. This class of lobed rosette is a common motive in East Gaulish (including German) ware (Knorr, 1921, ii, 3, style of RANTO; vii, 3, IANVS, late work; *Cannstatt*, xxxv, 1, 2, xxxvi, 1). The acanthus motive placed terminally or centrally or both occurs on Rheinzabern ware (Knorr, *Cannstatt*, xxxii, 1, 2, 4, 6).

In the field, a curvilinear object with splayed and rounded ends and central projection, repeated. (1) Mars (cf. Déch. 88 and Ludowici, M. 148). (2) Figure to 1. (cf. Déch. 491). These figures are so badly modelled that the identification can only be regarded as approximate.

Rheinzabern ware of the second half of the second century.

POTTERS' STAMPS

1. On Samian		
Decorated	16	
Plain	94	
		110
Uncertain or illegible (Dec.)		6
" " (Plain)		54
	Total	170
2. On imitations of Samian ware	2	
3. On a lamp	1	
4. On amphorae	9	
5. On mortaria	9	

Omitting seven Samian stamps which cannot be dated, the remainder may be tabulated for dating purposes as follows :

Pre-Flavian	9
Nero-Flavian	13
Flavian	9
First cent.	7
Domitian-Trajan	19
First half of second cent.	8
Antonine	20
Second cent.	15
Late second and third cents.	3
	103

It will be noticed that the proportion of second-century potters is considerably larger than in the previous report, but this change of proportions may most readily be understood when it is remembered that the majority of stamps here recorded were found when the top soil was being cleared in the winter of 1924-5.

A table of the pottery or district whence the stamps came is appended :

South Gaul :

La Graufesenque	29
" (doubtful)	3
Montans	1
Montans or La Grauf.	1
Pottery uncertain	14

62 REPORTS OF THE SOCIETY OF ANTIQUARIES

Central Gaul :

Lezoux	24
„ (doubtful)	3
	<hr/> 27

East Gaul :

La Madeleine	1
Eschweilerhof (?)	1
Pottery uncertain	6
	<hr/> 8

Germany :

Rheinzabern	1
„ (doubtful)	3
	<hr/> 4
Heiligenberg or Rheinzabern	1
Gallia Belgica (?)	1
Gaulish	14
Unassigned	7
	<hr/> Total 110

Among the uncertain stamps, three on decorated Samian are South Gaulish of which two are pre-Flavian ; in the plain section three more appear to be from South Gaul towards the end of the first century, while two are assigned to the latter half of the second, from Lezoux and Rheinzabern respectively.

Helpful parallels and evidence for stamps on *amphorae* and *mortaria* are unfortunately much rarer than for Samian, and those on amphorae incur the further disadvantage that the vessels themselves seldom give indications of their date. However, of the nine amphora stamps, two, nos. 13 and 15, can be roughly dated in the first half of the second century, while three, nos. 12, 14, and 18, are probably first century, as the handles are long and straight. Somewhat closer dating is obtainable in the case of mortaria, according to the type of rim ; three at least are definitely assignable to the first century, four to the 'turn' of the first two centuries, and the remaining two to the Antonine period.

STAMPS ON DECORATED SAMIAN

12. (A) ~~NNAMI~~ (retro). = CINNAMI. 37. Below ovolo, large letters. Two fragments, fitting, found in the top soil over the main E-W road.

Fair glaze and workmanship (pl. xxviii, nos. 5, 5 A).

Decoration : ovolo with plain tongue, separated from large wreath decoration by a bead-row. Vine-leaf with bunches of

grapes and an upright serrated leaf. This type of decoration with similar leaves occurs on other bowls of Cinnamus at Newstead II (Curle, 225, 4 and 7), Lezoux (Oswald and Pryce, xii, 3), and Vienna (Knorr, *Rottweil*, 1912, xxx, 8).

(B) |NAMI (retro). 37. Large letters, in decoration. Found east of the chapel site, 4 ft. 3 in. down.

Fair glaze and execution (pl. xxviii, no. 3).

Decoration: traces of an ovolo with swollen-tongue terminal bent to left, as in the Cinnamus bowl at Newstead (Curle, pl. xliiv). Beneath, a demarcating line, showing signs of rouletting. Free style decoration: part of an animal, probably a bear (cf. Déch. 818 bis, Lezoux).

The potter CINNAMVS worked at Lezoux (Déch. i, 162, moulds of Drag. 30 and 37); his bowls are typically Antonine, though he may have begun working towards the end of Hadrian's reign. On definitely dated Antonine sites in Britain, such as Newstead II, and the forts of Balmuilty and Barhill on the Antonine Wall, his stamps and style of decoration are well represented.

Curle, 223, 3; 217, 15; Miller, *Balmuilty*, xxxii, 1 a and b; xxxv, 70, 71; Macdonald, *Roman Wall in Scotland*, 373.

Late Hadrianic and Antonine.

13. (A) CINTVSM. 37. Rim-stamp. Top soil.

The potter Cintusmus (to whom are to be assigned probably the stamps CINTVSM, as well as those with the full name) worked both in Gaul and in the Rhenish district: (a) In Gaul: at Saint Bonnet, Iseure, in the Allier district, (Déch. i, 207, and *Proc. Soc. Ant.* xxii, p. 406, note), and at the chiefly Hadrianic site of Lavoye (Meunier, 1 *Rapport*, 1905; Forrer, pp. 212 and 226-7). (b) Rhenish district: at Ittenweiler, A. D. 102-130 (Forrer, p. 224), and at Rheinzabern (Lud. i, 15; ii, 20, 169). Fifteen stamps occurred at the Pudding Pan Rock (A. D. 140-190, *Proc. Soc. Ant.* xxii, 403), and one at Wroxeter in a deposit dated 'probably not after A. D. 150' (*Wroxeter*, 1913, p. 41). He made plain ware chiefly, and, as all his stamps on Drag. 37 are rim-stamps, it is concluded that his decorated moulds were borrowed (as Forrer first pointed out). For example, a bowl at York bearing his stamp has also the name Cinnamus in the decoration. His other Drag. shapes are 18, 27, 31, 33, and 38; he occurs commonly on British sites, e. g. Castlecary on the Antonine Wall, Corbridge (1910, etc.), and Silchester (May, *Silchester*, p. 213).

C. I. L. xiii, 10010, 573; vii, 1336, 315 (York, etc.).

Hadrian-Antonine.

14. (A) FELICIS MAN. 29. On concave base ; small neat letters. Found in low-level burnt layer under floor of room 1 in site 3. Probably not later than Flavian.

The potter Felix, who signs himself as above, worked at La Graufesenque (Déch. i, 83). The stamp occurs on Drag. 27 at Rottweil (p. 60) and Rottenburg (p. 69), where Knorr assigns him to the reign of Vespasian, also at Hofheim three times (Knorr, *Rottenburg*, p. 16), once on Drag. 29 (*Nass. Ann.* 1904, p. 72). His stamp occurs again on 29 at Vichy (St. Germain Mus.) and in the B.M. (Walters, M. 375). It is uncertain whether it is the same potter of La Graufesenque and Vespasianic date who signs OF FELICIS (see *Richborough* I, plain, no. 27) ; but he is to be distinguished from the later potter FELICIM, found at Silchester and Cirencester.

C. I. L. vii, 1336, 451 (York), xiii, 10010, 889. Vespasianic.

15. (A) PONTNI (retro). = FRONTINI. 37. Impressed on raised label above lowest band of decoration. Top soil. Fair glaze and workmanship (pl. xxvii, no. 4).

The design is closed by an upright striated leaf, repeated in series. This motive—or its variants—is not infrequent in the Flavian period (cf. Atkinson, *Pompeii*, 38 ; Knorr, *Rottweil*, 1912, vi, 1-13 ; Curle, *Newstead*, i, 211, 4). FRONTINVS worked at La Graufesenque (Déch. i, p. 83) in the Flavian period and his work has been found at Aislingen, Rottweil, Carlisle, Corbridge, Wroxeter (1924), Newstead I, Camelon, Heddernheim, Cannstatt, and in the Bregenz Cellar-find (A. D. 80-110). He does not occur in the Vespasian period at Hofheim or Pompeii, but is especially plentiful at Rottweil. His chief output may be assigned to the late Vespasian-Domitian period. His decorated work is typically Flavian (cf. Curle, 209, 1 and 4 ; Knorr, *Rottweil*, p. 60, and 1919, 33 ; Walters, M. 289). He made forms 18, 27, 29, 31, 33, and 37.

See also *Richborough* I, no. 29 (A), plain ware.

C. A. D. 75-110.

16. (A) \NVSF̄ = IANVSF̄. 37. Beneath ovolo. Top soil, north-west of site 1.

Fairly good glaze and workmanship (pl. xxviii, no. 9).

Neatly formed ovolo, the tongue of which has a slightly swollen terminal. Beneath the ovolo, a cable-like demarcating line. In the field, the remains of a 'milled' winding scroll. The potter IANVS employed many types of ovolo (cf. O. and P. xxx, 96, 97, 98, 99), but the exact facsimile of the *Richborough* example is found on a form 37 at Cannstatt (Knorr, 1921, vii, 1). The cable-like

demarcating motive is highly characteristic of his work (cf. *op. cit.* vii, 1, 3-9). The 'milled' scroll, medallion, or festoon is also frequently found on his signed bowls (cf. O. & P. xiii, 2; Knorr, *Cannstatt*, 1921, vii, 1, 4, 5).

This potter worked in East Gaul in the first half of the second century, chiefly at Heiligenberg and Rheinzabern. His moulds have also been found at La Madeleine. His early activity was chiefly associated with Heiligenberg, where much of his work has been found. Forrer (*Heiligenberg*, p. 153) dates his period for this pottery *circa* A.D. 95-120 and illustrates many examples of his ware (figs. 56-81 and pls. xxvi-xxx). His early work is also illustrated by Knorr (*Rottenburg*, pl. xi; *Cannstatt*, 1921, vii, 1, 2, 4-11). Subsequently, he migrated to Rheinzabern, where, according to Reubel (*Römische Töpfer in Rheinzabern*), he began to work about A.D. 120.

In Britain his stamp has been recorded on decorated ware in London (Walters, M. 456), Nether Denton (*Arch.* 64, fig. 21), York, Corbridge (*Report*, 1911, p. 57), and Wroxeter (*Wroxeter*, 1924). The example from Nether Denton may be dated in the early second century, whilst that at Wroxeter is of a later type and was found under conditions which suggest a mid second-century date.

Period of the Richborough fragment: Trajan-Hadrian.

Typologically, the decorated ware of IANVS is quite distinct from that of IANVARIS of Lezoux.

17. (A) ΛΛΟΧΙΑ/ = MOXI M. 37. Rim-stamp. Top soil.

There appear to be two potters MOXIVS or MOSSIVS; one of Lezoux (graffito in mould—Déch. i, 288) dated by Knorr in the time of Vespasian (*Rottweil*, 1907, p. 64, on Drag. 18); the other of the middle second century or Antonine period, also of Lezoux. For this later date the evidence is the Drag. form 79 (no. 97 A of this Report), an Antonine deposit at Wroxeter (1912, p. 55) and Drag. 38 at Corbridge (*Arch. Ael.* xii, 283). Oswald and Pryce, however, consider that there were two potters working within the Domitian-Hadrian period (p. 119). Though chiefly occurring on plain ware, his stamp is recorded on Drag. 37 from Wroxeter (1912, no. 14, p. 45), struck diagonally on the rim, and a graffito has been found (retro) on a mould, now in the Chester Museum, written on the plain band below the decoration (narrow metopes and panels: floral ornament, Déch. 1153, Lezoux; spiral, as *Newstead*, p. 221, 6, 'Antonine'). His or their stamps occur frequently in Gaul and Britain; the Drag. forms used are: 18, 18/31, 27, 31, 33, and 37.

The stamp MOXXIM occurred at Segontium, in 1920, in pit 4, dated c. A.D. 80-120, probably belonging to the Flavian potter. The stamp MOXSIVS F, however, which has been found several times at or near Trier, and only on German sites, probably belongs to a separate potter in East Gaul.

C. I. L. xiii, 10010, 1391; 10011, 95; xii, 5686, 607; *Chester Arch. Soc. Journal*, N.S., viii, 98, and xxvi, 11.

18. (A) PATRI (retro). 37. Impressed on vertical raised label, between festoons. Top soil over main E-W. road. A stamp of PATRICIVS.

Fair glaze, but rather coarse workmanship (pl. xxvii, no. 6).

Zonal decoration, demarcated by a badly executed wavy line. In the upper zone: (1) a speckled hare running right, over conventional blades of grass, a common Flavian type (cf. Atkinson, *Pompeii*, 31 MANDVILLVS, 40, 42, 48, 49; Knorr, 1919, 81 A, VITALIS); (2) two rosette terminals, an oblique wavy line, and a repeated leaf ornament. In the lower zone is a continuous festoon, the spirals of which end in rosettes and the intervening tassels in arrow-heads. Festoon decoration, either continuous or interrupted, is especially common in the Flavian period and is frequently met with at Pompeii, Rottweil and Newstead.

PATRICIVS worked at La Graufesenque (Déch. i, 84, OFPATRI, etc.) in the Nero-Flavian period. His stamps have been found in the pre-Flavian layers at Novaesium and Wiesbaden, at Hofheim II, Rottweil, Pompeii, Carlisle, Camelon, Friedberg, and Cannstatt. His decorated work is typically Flavian (cf. Atkinson, *Pompeii*, 34). He made forms 15/17, 16, 18, 18/31, 24/25, 27, 33, also 29, 37. He is to be distinguished from the later potters of the same name, who worked in Central and East Gaul.

See also *Richborough*, I, no. 46 (plain), p. 74. Flavian.

19. (A) OFRVFIN = OFRVFINI. 29. Centre of base. Top soil.

Rufinus of La Graufesenque worked between the years A.D. 60-85, and flourished in the time of Vespasian. For references, see *Richborough* I, no. 54 (plain), p. 77. Note two examples on Drag. 29 in the Pompeian hoard. Chiefly Vespasianic.

20. (A) VRINNY = SACRILLI M. 37. Rim-stamp. Surface, west of site III.

Sacrillus was a Lezoux potter (Allier district: *Coll. Antiq.* vi, 74, and in the Plicque collection) who usually made plain ware, Drag. shapes 18/31, 31, 33 and 79. One other rim-stamp on 37

has been found at Wroxeter (1914, p. 42). His date is fixed as about A.D. 140-180, as his stamp occurred at Pudding Pan Rock (*Proc. Soc. Ant.* xxii, p. 403) and at Astwick in a group dated A.D. 140-160 (*V.C.H. Beds.* ii, 4). The name is occasionally written with only one L; his stamps are fairly common in Gaul and on British sites.

C. I. L. xiii, 10010, 1698; vii, 1336, 975; Corbridge, *Arch. Ael.* xii, 285; *Kenchester*, p. 74, no. 15. Antonine.

21. (A) **CVLB** retro. 37, impressed on raised label among decoration. Topsoil. Probably = C. VAL(erius) ALB(anus). Fair glaze and workmanship (pl. xxvii, no. 7).

Zonal decoration, the zones being separated by a straight chevron-wreath which is bordered above and below by wavy lines (cf. Atkinson, *Pompeii*, 38, 39, 41-5, 49). In the upper zone, indeterminate animals. In the lower zone, festoons, the spiral of which ends in a cuneiform, spurred and stipuled leaf; part of an intervening tassel of wavy contour. The cuneiform, spurred and stipuled leaf occurs in the work of the early potters BASSVS, DARIBITVS, and INGENVVS, but is especially characteristic of the products of the later or Flavian potters. Good examples occur at Pompeii (*op. cit.* 24 SECVNDVS, 36 RVFINVS, 57, 63, 77), Rottweil (Knorr, 1912, pl. vii), and Newstead I (*Newstead* 205, 3; 213, 3).

On a raised label in the upper zone is the stamp, previously read as C. ANT B. The decipherable lettering of the same stamp (retro) is seen on a Flavian form 29 at Nijmegen (Knorr, 1919, 87D). Compare also with the stamp **CVTP** or **CVTB** on a Flavian form 37, found in London (Price, *Antiq. found on the site of the Nat. Safe Deposit premises, Q. Vict. St.*), now in the Guildhall Mus. Another similar stamp is in the same museum (S. 59) on Drag. 37 with two zones containing typical Flavian decoration. Compare also *C. I. L.* xiii, 10010, 135, 'litteris cavis'; the stamp occurs also at Ribchester and Wroxeter (1925). This stamp should be looked at upside down, when it reads **CVLB** = C. VALB, which is likely to be the monogram of the potter C. VALERIVS ALBANVS, probably of La Graufesenque, who is placed by Knorr early in the reign of Vespasian (*Rottweil*, 1907, p. 57). Ligatures are a feature of his stamps, e. g. C VA • ALBAI, G • VA • ALB; his stamp occurs retrograde at Neuss (*Bonn. Jahrb.* III/12, 336). He also made Drag. forms 18, 27, and 33. His decoration is typical of the Flavian period of South Gaul.

C. I. L. xiii, 10010, 1960 (and 135); xii, 5686, 907.

Flavian.

22. (A) ꝛEC = VEREC(undus). 37. Impressed on vertical raised label among decoration apparently in panels; poor brownish-red glaze. Top soil.

The stamp VEREC occurs at Rottenburg and Heiligenberg, but in each case it is styled 'Gaulish', and probably came from an East-Gaulish pottery (see no. 116, p. 86).

STAMPS OF POTTERS THAT ALSO OCCURRED AT RICHBOROUGH
IN 1922-3

2. (B) DOHCCVSVK = DOECCVS FE. 37. Rim-stamp. Top soil. Good execution (pl. xxviii, no. 1).

Ovolo with slightly swollen tongue-terminal. Panel decoration, demarcated by rows of large beads. In one panel, the remains of a large medallion containing a foliated object. A large astragalus in the field, as on a bowl by Doeccus at York.

- (c) DOV. 37. Vertically among ornaments. Top soil above main E-W road. Two fragments of same bowl.

Fair glaze and execution (pl. xxviii, nos. 2 and 2 A).

Panel decoration, demarcated by rows of large beads.

(1) Vertical ornament (Déch. 1114, variant) composed of an astragalus, conjoined dolphins, plant with pendant buds, birds, and tripod, the whole being probably crowned with an anchor-like ornament.

This 'vertical' occurs in the work of the Lezoux potter BIRRANTVS (Behrens, *Katalog Bingen*, 1918, 12, 4), in the Trajanic period and on a Trajan-Hadrian form 30 at Brecon.

(2) Diagonally fluted column.

(3) Panel containing (a) two detached leaves (cf. Curle, *Newstead* ii, 221, 6); (b) Crater with an acanthus leaf; and (c) a pair of pointed leaves with serrated borders. A heavy moulding closes the design. The foot-stand is of the large broad Antonine type.

The potter DOECCVS or DOVECCVS worked at Lezoux (Déch. i, p. 269, mould of form 37). All the decorated bowls signed DOHCCVS, DOHCCI, and DOVHCCVS carry ornamentation of the Hadrian-Antonine type (cf. Walters, M. 1031; May, *Silchester*, xxvi, 44, 46, 48; May, *York*, vii, 2). His ware is chiefly found in Gaul and Britain. He made forms 30, 31, 32, 33, 37, 38, 79, and Curle 15.

Occasionally the stamp of DOECCVS is associated with a large monogram DD, (cf. Déch. i, p. 269), which may be repeated on the same bowl.

It is necessary to distinguish this monogram from the smaller and more frequently repeated **DD** of a potter or potters who were working as early as the 'turn' of the first and second centuries (**DD** on a form 37, at Brecon; form 29, of late type, at Caerwent; form 30 from London; and form 37 in the British Museum, M. 1148) and in the Trajan-Hadrian period at Blickweiler (cf. Knorr, *Cannstatt*, iv, v, 4; xv, 1, 2, 3, 4; *Cannstatt*, 1921, vi, 4-8, 10). Owing to the long period of time during which the monogram **DD** appeared on decorated sigillata (from about A. D. 90-180) it is impossible to identify the earlier potters who used this monogram with **DOECCVS** and (large) **DD** of Lezoux. The stamps of Doeccus have not been recorded in association with the earlier and smaller monograms.

Cf. also *Wroxeter*, 1912, xv, 11, and *Richborough* I, p. 56.

Hadrian-Antonine.

5. (B) **MERCA**  (retro). 37. Amongst the decoration. By E-W road in sand above lowest road metal.

Very fair glaze and workmanship; narrow plain band above the ovolo, which has a three-pronged tongue-terminal.

Free style decoration of alternating trees and stags, bordered above and below by coarse wavy lines (pl. xxvii, no. 11).

(1) Trees with twisted stems and many-lobed leaves, after the manner of the Nero-Flavian potter **GERMANVS** (Knorr, *Rottweil*, 1907, viii, 1), but of coarser execution; upon each tree is perched a bird, right.

(2) Sitting stag right (Déch. 845), as used by **GERMANVS** (Knorr, *loc. cit.*) **M•CRESTIO** (Knorr, 1919, 28 B) and **SECVNDVS** (*op. cit.* 74 c). This stag also occurs in the Bregenz Cellar-find (O. & P. xvi, 4).

(3) Sitting stag left (Déch. 862, NIC/), as in the work of **SECVNDVS** (Knorr, *loc. cit.*). Similar trees and stags *vis-à-vis* occur on the same **SECVNDVS** bowl.

(4) A straight wreath, composed of repeated trefoil leaves, forms a lower border to the design. This wreath is highly characteristic of the work of this late Flavian potter, Mercator, (Knorr, 1919, 57 B, F, G). The stamps **MERCATO** and **OFMERC** are the impressions of a South Gaulish potter who probably worked at Montans, in Domitian's reign. It is also probable that his activity extended into the reign of Trajan. Déchelette (i, pp. 286-7) places bowls signed **MERCATO** amongst Lezoux ware, but a glance at their figure-types clearly demonstrates that they are of South Gaulish fabric. All the recorded and illustrated decorated

bowls with the stamp MERCATO have ornament of a definitely South Gaulish and Flavian type (cf. Knorr, 1919, 57; text-fig. 47; O. & P. xv, 1; May, *Silchester*, xxv, 5-7).

This potter made forms 29 (OFMERC Baden-Baden and Vienne, MERCATO Friedberg), 37 and 18, 18/31, 27, 31 and 33. He should be distinguished from the later MERCATOR who worked at Lezoux in the Hadrian-Antonine period. The stamp of the Lezoux potter is written MERCATOR•M (Déch. i, p. 286, mould at Lezoux) or MERCATOR. Usually the O is small in this signature. The date of his activity is attested by the occurrence of his stamp on a mould of the potter CINNAMVS (*Wroxeter*, 1912, xvi, 18).

Forrer (pp. 129-30) considers that a potter of this name worked at Heiligenberg.

At both Heiligenberg (Forrer, p. 234) and Rheinzabern (Lud. i, 55; iii, 44) the full lettering, MERCATOR, occurs, as at Lezoux.

See *Richborough* I, p. 57.

A.D. c. 80-110.

6. (B) OF MO  W. 29. Centre of base. Top soil. Stamp of Mommo, of La Graufesenque. See *Richborough* I, p. 58. Nero-Vespasianic.

UNCERTAIN AND FRAGMENTARY STAMPS

 W 29. Centre of base. Top soil.

A complete but mis-struck stamp, possibly the end of the name AMAND(VS), a potter of La Graufesenque and Montans, dated by Knorr (1919, p. 16) A.D. 30-60; probably in Britain A.D. 40-80 (*Wroxeter*, 1914).

OF/ 29. In lower frieze of ornamentation. Found at the lowest level, west of site III. Several pieces, mostly fitting (pl. xxvi, no. 1).

Good glaze of medium brightness; fine modelling; non-everted lip. The upper moulding of the rouletted rim is deeper than the lower, a feature already present in Claudian sigillata (O. & P. iii, 9, AQTIVANVS; Ritterling *Hofheim I*, xxiv, 9, MOD[ESTVS]). In earlier sigillata of Tiberian type the rim has either two equal mouldings or a single one (cf. O. & P. iii, 4 BILICATVS, 5 SENICIO, 6 SCOTTIVS and 7).

Upper frieze: *rinseau* decoration. From the stem of the scroll diverge a spiral, a stalk ending in a rosette, and a stalk terminating in a five-bladed leaf (cf. Knorr, 1919, 8 B, AQTIVANVS, Claudian period; Walters, M. 201, MEDDILLVS; Atkinson, *Pompeii*, 22, MOMMO, Vespasian period).

The points of divergence of the stalks from the parent stem are marked by a 'bifid tendril-union' composed of a bifid leaf and two beads. This type of union occurs in the early work of AQTIVANVS (Knorr, 1919, 8 A) and in that of the early potters BALBVS, CRESTIO, and LICINVS (*op. cit.* 11 B, 27, 45 A) and also on craters of the Tiberio-Claudian type at Bregenz (*op. cit.* 3 M, N, O).

At the junction of the five-bladed leaf with its supporting stalk is placed a bead (cf. *op. cit.* 53, MATVGENVS, for a similar leaf with three beads at juncture; from Hofheim I). The same five-bladed leaf also occurs in the work of the Claudian potter GALLICANVS (*op. cit.* 33).

The scroll is bordered above and below by rows of large and well-spaced beads, a feature which is frequently in this situation in sigillata of Tiberian type (cf. O. & P. iii, 4, 5, 6, 7).

Plain central moulding, bordered above and below by rows of large beads.

Lower frieze: The decoration consists of alternating cruciform ornaments and medallions, a scheme already well established in the Claudian period (cf. Ritterling, *Hofheim*, xxiv, 3, 10; O. & P. iii, 9, AQTIVANVS). This *regular* alternation of cruciform ornament and medallion is highly characteristic of pre-Flavian sigillata, but it also persisted into the Vespasianic period (Atkinson, *Pompeii*, 3, 5, 13, all by MOMMO).

The *cruciform ornament* is composed of fine diagonal and vertical wavy lines with rosettes at the junctures—both in the centre and at the corners.

The central spaces are occupied by three stalks which terminate in poppy-heads (cf. Knorr, 1919, 75 A, SENICIO, early Claudian, and Atkinson, *Pompeii*, 11, MOMMO, Vespasianic). In the lateral spaces are curved stalks ending in serrated and pointed leaves.

The corner-tendrils end in five-bladed leaves as on the upper frieze. At the junction of the leaf and the stalk is placed an astragalus ornament. The definition of the junction of the leaf with the stalk by means of a bead or beads, an astragalus, a bifid leaf, or other motive is an early feature and occurs in the work of BALBVS (Knorr, 1919, 11 A), CARVS (*ibid.* 20 E), MATVGENVS (*ibid.* 53 E, Hofheim I), SENICIO (*ibid.* 77 J), and DARIBITVS (*ibid.* 90 B).

The medallion contains an upright plant terminating in a multifid leaf. Two lateral stalks diverge from the stem and end in long, many-lobed leaves, as in two pre-Flavian bowls, form 30 (*ibid.* 42 M and 96 A), in the work of the early potter, MVRRANVS (*ibid.* 59) and that of the Nero-Vespasianic potter, PASSIENVS (*ibid.* 64 H).

Then follow two bilaterally arranged, curved leaves similar to those used by the Tiberio-Claudian potter VAPVSO (*ibid.* 8).

Medallions enclosing an upright plant are characteristic of pre-Flavian sigillata and are found in the work of the potters BILICATVS, DARRA, SCOTTIVS, AQVITANVS, and MELVS. They also occur on early bowls by FELIX (Knorr, 1919, Text-fig. 19) and PRIMVS (*op. cit.* 66). A good example occurs on an early Claudian form 29 by POTITVS in the London Museum. Rarely, the medallion enclosing a plant persisted into the Flavian period (Atkinson, *Pompeii*, 9 and 14, MOMMO).

The design is closed by fine flutings, immediately above which is the stamp.

Many of the decorative motives on this bowl are found in the work of OFMVRANI, *i.e.* the pendent ornament in the medallion (29 by MVRANVS in the Guildhall Museum); the upright ornament in the medallion with its ogee-like leaves (29 by MVRANVS in the London Museum).

On the other hand, this type of leaf is also characteristic of the work of VAPVSO. Compare also the Murranus bowl in the Price Coll., Soc. Ant. of London.

As there is a slight indication that the first letter was M, it may well be that the Richborough bowl was stamped by Murranus as suggested in the illustration. Claudius-Nero.

S 29. In decoration. Top soil, west of site III.

Good glaze and workmanship (pl. xxvii, no. 9).

Upper frieze: festoon, the spiral of which terminates in a rosette. Above and below the festoon are remains of bead-rows. The letter S probably represents the initial letter of SABINVS, spaced out (cf. Oswald and Pryce, lxxxv, 2). Early Flavian.

MI 29. Centre of base. Top soil. Unassignable.

Finally there was one completely illegible stamp (Drag. 37) on a narrow raised panel, between beaded lines, much worn, found in the filling of ditch, near the chapel; and a portion of an illegible graffito in raised letters below decoration.

STAMPS ON PLAIN SAMIAN

67. (A) AESTIVIM. 31, thin. Top soil.

Aestivus or Aistivus (the Gaulish form of the name), who always used the genitive case and M, was a Lezoux potter of plain ware of the middle and second half of the second century.

Fourteen stamps are recorded from Pudding Pan Rock (*Proc. Soc. Ant.* xxii, 403), and they are common on other British sites,

especially London, Silchester, and York. He used Drag. shapes 18/31, 27, 31, 33, and 38.

C. I. L. xiii, 10010, 49 ; vii, 1336, 21. *c.* A. D. 140-190.

68. (A) $\text{ALBILLI}\cdot\text{M}$. 27 (or small 38). Top layer, west of site III.

This potter, who also made decorated bowls occasionally, worked at La Madeleine (East Gaul) in the first half of the second century (*O. R. L.* xxxiii, *Stockstadt*, p. 100). At Heddernheim his stamp was found with a coin of Trajan (*Hedd. Mitth.* v, pl. v, fig. 3, p. 15, grave 42); at Saalburg in the Hadrianic earth-fort (Jacobi, p. 317, 3). The same potter is probably responsible for the stamps recorded at Heiligenberg (Forrer, p. 231) and at Rheinzabern (Lud. iii, 1-2). Fölzer notes that his influence in decorated wares is seen at Trier and Remagen (pp. 12-13). He used Drag. shapes 18, 31, 33, 37, and Lud. Tq (= Dr. 18/31) Sa (= Dr. 40).

C. I. L. xiii, 10010, 79 ; vii, 1336, 36 b ; Oswald and Pryce, xviii, 2, and p. 59 ; *O. R. L.* lix, *Cannstatt*, pl. iv, 1, Knorr, *B. and E.*, p. 105. *c.* 100-150 A. D.

69. (A) ΑΣΙΑΤΙΚΟΥΣ (retro), 18. Top soil.

(B) $\text{ΑΤΙCΙ}\cdot\text{ΟΦΙCΙ}$. 18/31. Top soil.

Asiaticus made plain wares only, at Lezoux. In 1881 Plicque uncovered what seemed to him Asiaticus's house, with his punches (Déch. i, 146 and 234). He worked in Antonine times and has often been recorded on British sites, using Drag. forms 31, 33, and 40.

C. I. L. xiii, 10010, 178 ; vii, 1336, 94. Antonine.

70. (A) $\text{ATILIANI}\cdot\text{M}$. 18. Top soil.

Moulds of this potter, who also rarely made decorated bowls, have been found at Lezoux (Déch. i, 157) and Moulins (graffito, *C. I. L.* xiii, 10011, 33 b). Eighteen of his vessels found at Pudding Pan Rock date his activity between A. D. 140-190 (*Proc. Soc. Ant.* xxii, 403). One circular stamp is recorded from Colchester (Walters, M. 1683). He used Drag. forms 31, 32, 33, 37, 38, and 79.

C. I. L. xiii, 10010, 194 ; xii, 5686, 90 ; vii, 1336, 99 ; iii, 6010, 244, (Bregenz). Oswald and Pryce, p. 61 (chiefly Hadrian-Antonine). *c.* A. D. 140-190.

71. (A) ΑΤΡΙ 27. Top soil.

A little-known maker of plain pottery, who also stamps ΑΤΕΡ and ΑΤΕΡΙ . In Britain, his stamps occur at New Southwark St., London (Pitt Rivers Mus., Oxford), and at Cirencester. His

74 REPORTS OF THE SOCIETY OF ANTIQUARIES

provenance is unknown, though he may possibly be an East-Gaulish potter of the second century. Also possibly these bowls may be of a potter PATER, stamped with a broken punch.

C. I. L. xiii, 10010, 190; ii, 4970, 63; xii, 5686, 94; Lud. i. 5; ii, 266 (on $\text{Sa} = \text{Dr. } 40$).

72. (A) AVIT/ 31 (early). Neat lettering. On under side is scratched $\text{I} \neq \text{K}$. Top soil.

Excluding the Belgic terra-nigra potter, of whom there are three examples from the early site of Weisenau (*C. I. L.* xiii, 10010, 238, ee), this stamp might belong to one of five different sigillata potters with the name AVITVS, who worked respectively at La Graufesenque, Lezoux, and the East-Gaulish sites of Eschweilerhof, Ittenweiler, and Rheinzabern (the last two are probably identical). Though the loss of the termination makes it impossible to decide for certain, the first-named is the most likely, dated in the Domitian-Trajan period by Oswald and Pryce (Wheeler, *Brecon*, p. 233). A Lezoux provenance for this stamp is less probable, and the latest date must be early in the second century.

C. I. L. xiii, 10010, 237/8; 10011, 157; iii, 6010, 33; 12014, 14; vii, 1336, 124/5; xii, 5686, 113, 116; Fölzer, p. 145; Forrer, p. 215; Lud. i, 86; ii, 15, 288; iii, 9; iv, 7, 8.

? A. D. 80-120.

73. (A) BEUUCIM (retro) = BELINICIM. 18/31 or 31, good glaze. West of site III, second layer.

(B) BELINIC/ (retro). 31, good glaze. Top soil.

A Gaulish potter of the second century but of uncertain provenance, found at:

Rottweil (Knorr, p. 57), 'Vespasian-Domitian'.

Neuss, 25-105 A. D.

Wroxeter (1914), 'late first-early second cent.'

Newstead, (pit cv, p. 232), with Antonine pottery.

Barhill, Antonine.

Neckarburken, in castello occidentali, erected c. 145 A. D.

A stamp of Belinicus is also recorded from Sewage Farm, Milton, Cambs., on Drag. 79, dated A. D. 140-190. Oswald and Pryce, p. 61, date him as Hadrian-Antonine, which is supported by his Drag. shapes 18/31, 27, 31, 33, 38, and 79. He is common on British sites.

C. I. L. xiii, 10010, 281; vii, 1336, 138, 139, 141; xii, 5686, 124.

74. (A). **BoVD/** (retro). 31, bright glaze. Top layer, west of site III.

Boudus made plain pottery in East Gaul. His stamps occur at Neuss (*Bonn. Jahrb.* 111/12, 338) and at Miltenberg and Ochringen on the Outer Limes. Barthel (*Zugmantel*, xxxii, p. 133) assigns him to the reigns of Hadrian and Pius. His stamp has previously been found in Britain at Bayford (Kent), London, and South Shields. His Drag. forms are 18/31 (= Lud. Tq from Rheinz.), 31 and 33.

C. I. L. xiii, 10010, 347.

c. A. D. 120-160.

75. (A) **CAMB/** On a thick concave base, yellow-red glaze. Filling of outer ditch, west of site III.

It is uncertain whether the complete stamp was that of a Central Gaulish potter, **CAMBVS F** (and **CAMBIM**), or of **CAMBO**, who is assigned to Eschweilerhof in North-east Gaul; a mould bearing his stamp has also been found at Blickweiler. The wares of the former have been found on several British sites (e.g. three each from Corbridge and London) and he made Drag. forms 31, 33, and 38. The latter made 31, 33, and 37, and his stamp has been found at Praunheim (grave 55), with coins of Trajan and Hadrian, and on the outer Limes. The fabric and glaze of the Richborough specimen favour an East-Gaulish origin. Oswald and Pryce (p. 29 and p. 108) suggest two potters and give their date as Hadrian-Antonine.

Cambus: *C. I. L.* xiii, 10010, 414; xii, 5686, 163; Walters, *M.* 1944, 2063.

Cambo: *C. I. L.* xiii, 10010, 413; Fölzer, pp. 45-7, pl. xxxii, 965 ('time of Pius', A. D. 138-161); Knorr, *B. und E.*, pl. 16, fig. 1.

About the middle of the second century.

76. (A) **CAPITOF** Large concave base (? large 25). Top soil.

This pre-Flavian potter of South Gaul made only plain wares; his stamp has occurred twice at both Hofheim (Claudian camp, 40-51) and Sels tilery (ends c. 40). He used Drag. 24, 25, and 27. He should be distinguished from the Arretine potter, M. Perennius Capito.

C. I. L. xiii, 10010, 442; ii, 4970, 119-20; xii, 5686, 176; xv. 5085; Oswald and Pryce, p. 50; Ritterling, *Hofheim*, p. 244.

Pre-Flavian.

77. (A) **∕ANIF = CARANTIF** 18. Top soil.

Carantius is a Mid-Gaulish potter of plain wares, for whom Walters suggests a Lezoux provenance. His stamps have been

76 REPORTS OF THE SOCIETY OF ANTIQUARIES

found previously in Britain, at London (Walters, M. 1608-10) and at York, always on Drag. 18. One stamp on Drag. 27 occurs at Wiesbaden (*O. R. L.* xxxi, *Steinkastell*, A.D. 83-122).

C. I. L. xiii, 10010, 451.

c. A.D. 80-120.

78. (A) OF•C•N•CELSI 18. Within rouletted ring. }
 (B) OF•C•N•CIIIL 18/31. Fine glaze; within circle. } Top soil.
 (C) OF C•N/ 18 Slight 'kick', fine glaze. }

This Gaulish potter, whose provenance and date are uncertain, has been recorded from Wroxeter (1914, 245, A), London (Guildhall), and York (on a thin Drag. 18, with good dark brown glaze). He also used Drag. 33.

C. I. L. xiii, 10010, 1400. Presumably of the first century.

79. (A) CVCAL\ . 79. Filling of inner ditch, by E-W road.

Cucalus is probably a Lezoux potter, of Antonine date; an identical stamp has been found at Canterbury on a small Drag. 33 and at Wilburton, Cambs., on a large 33, with a patchy glaze. His ware is common on British sites.

C. I. L. xiii, 10010, 716.

Antonine.

80. (A) /VDIM = CVDIM. 31. Top soil.

Cudus has also been found at Newstead (p. 325, no. 38, on Drag. 31).

C. I. L. xiii, 10010, 720. Heddernheim, Poitiers, Vechten, and Tours.

C. I. L. xii, 5686, 287. Vienne and Vaison.

„ iii, 12014, 235. Bregenz and Gunzburg.

81. (A) OF CVS = OF CVS. 33. Small. Top soil.

A rare maker of plain pottery in South Gaul, probably at La Graufesenque (*Déch.* i, 83). His stamp has also been found at Basle and in the Flavian period at Windisch.

C. I. L. xiii, 10010, 731.

Flavian.

82. (A) DRAVCIM. 79. Top soil.

Draucus appears to be a South-Gaulish potter, possibly of Montans; his stamps occurred in the later camp at Hofheim (A.D. 74-83), at Corbridge in 1912 (site 41, dated 90-105), and at Newstead (Curle, p. 236, 43, 'of the second century'). Oswald and Pryce (p. 113) assign him to the late first and early second centuries. This example is dated by the Drag. shape in the latter half of the second century, and therefore must belong to a second Draucus, not of Montans. The name is also recorded from

London, Chester, Bitterne (Drag. 33), and probably from Corbridge. His Drag. shapes are 18/31, 31, 33, and 37.

C. I. L. xiii, 10010, 820; xii, 5686, 324.

83 (A) **ECVETER** 31, high 'kick', good brownish red glaze. Site III.

Stamps of this potter, who does not occur in *C. I. L.*, have previously appeared in Britain at Colchester (on Drag. 33, Walters, *M.* 2100), at Corbridge (on Drag. 31, 1906-14, *Arch. Ael.* 1915, 280), and on a small Drag. 33 in the London Museum (A 12099, also of brownish red glaze). The ligature of **T** and **E** is common to all examples. Second century.

84. (A) **ERICI•M** 40. Top soil.

Knorr treats Ericus as a South-Gaulish potter of Domitianic date; his stamp was found at Stockstadt (Drexel, *O. R. L.* xxxiii, 102, about A. D. 100) and in a deposit at Wroxeter dated 80-120 (1914, p. 52), also in Britain at Hambleden, Cirencester, and Corbridge. He used Drag. forms 18/31, 27, and 31. Four examples associated with early second-century stamps were recorded at Bitterne, and one from Camelon was probably Antonine.

C. I. L. xiii, 10010, 860; Knorr, *Rottweil*, 1907, p. 60.

Probably A. D. 100-150.

85. (A) **ESCVSIM.** 33. Top soil.

Escusus usually made Drag. 33, though his stamp occurs on 31 in the British Museum (Walters, *M.* 1964) and at Leicester, and on a rim of 37 at York. His ware is fairly common on British sites; at Kenchester (*Woolhope F. C. Report*, 1913, no. 26) he was doubtfully assigned to Central or East Gaul, late in the second century.

C. I. L. xiii, 10010, 865; vii, 1336, 442.

86. (A) **O•FIRMON'S.** 18, within rouletted ring. Top soil.

Firmo was a potter of La Graufesenque, whose ware occurs frequently on pre-Flavian sites: three examples each from the Sels tiliary (before A. D. 40) and the legionary camp at Neuss (before A. D. 70); one from the early period at Wiesbaden (before A. D. 69); finally five examples from the first occupation of Hofheim (A. D. 40-51), and none in the later (A. D. 74-83). Knorr places him between the years A. D. 30-55. The specimen found with the stamps **OF MASCVLI** and **SABINVSF** at Newstead (Curle, p. 237) and dated A. D. 80-100 may be taken therefore to be a survival. In Britain examples occur at Silchester (May, p. 222) on Drag. 25 with handles, at Christ's Hospital, Cirencester and London (thrice, one on Drag. 29). He used Drag. forms 18, 18/31, 25, 27, and 29.

C. I. L. xiii, 10010, 900; xii, 5686, 363; ii, 4970, 196; Ritterling, *Hofheim*, 245, 249. Pre-Flavian.

87. (A) GEMINAA = GEMINI MA(nu). 45, light brown glaze ; stamped diagonally upwards on collar. Top soil.

This is not a stamp of the first-century Lezoux potter, who used the nominative case, but of a second-century potter found frequently in Britain. A stamp at Newstead was found with a coin of Trajan ; at Corbridge with two new dupondii of Marcus and some Antonine pottery. His name occurred in two pits (35 and 41) at Wroxeter in 1913, in each case with Antonine pottery, and again at Balmuildy (A. D. 140-70). Barthel assigns his work to the first half of the second century (*O. R. L., Cannstatt*, lix, p. 54, 66), which appears to be earlier than the evidence would warrant. A similar stamp on the collar of Drag. 45 is figured by May (*York Pottery*, pl. iv, fig. 5). He also used shapes 18/31, 31, 32, 33, 38, and 43. See also *Richborough I*, Dec. 3 (A), p. 56.

C. I. L. xiii, 10010, 955 ; vii, 1336, 477 ; xi, 6700, 312 ; xii, 5686, 383 ; *Corbridge* (1911, p. 39). Antonine.

88. (A) GENALISF = GENIALIS F 27 or Hofheim 8, good glaze. West of site III, top soil.

An identical stamp is recorded on Drag. 29 by Knorr (1919, pl. xxxiii) and dated A. D. 50-60. A graffito proves that he worked for the potter Germanus (*Bonn. Jahrb.* 1925, 130, p. 50). His stamp was found on Drag. 33 at Wroxeter in a deposit dated 80-120 A. D. (1914, p. 52 ; pit 66). There was also an Antonine potter of this name, who worked at Rheinzaubern and used a different stamp. In Britain, the later potter is recorded from Bar Hill on the Antonine Wall and the earlier in the Guildhall Museum (on Drag. 18). This example probably comes from La Graufesenque.

C. I. L. xiii, 10010, 959 ; ii, 4970, 216 ; Oswald and Pryce, p. 81, 'Nero-Vespasian' ; Walters, M. 2313-14, 2337. c. 50-80.

89. (A) IANVA/(retro) = IANVARIVS. 18/31, good glaze. Top soil.

There are several potters of the name Januarius ; as this stamp is incomplete and nothing identical has been previously recorded, it is impossible to say to which this example should be attributed.

C. I. L. xiii, 10010, 1002.

90. (A) IARVSFF 33. Light orange-red glaze. Site III, 4-5 ft. down.

This very uncommon potter also made 'patella nigra' (Belgic ware), an example being recorded from Silchester and from Trier. The unusual termination, which is quite certain in the Richborough example, has not previously been noted.

C. I. L. xiii, 10010, 1006; May, *Silchester*, p. 272 and pl. LXXXII, 2.

91. (A) OF.LAB 27. Top soil.

This potter signed Labeo or Labio on plain ware, but the latter only on decorated. He was a pre-Flavian potter of La Graufesenque. See *Richborough* I, Dec. 4 (A), p. 57, for details.

92. (A) LOGIRNI 18. Top soil.

Logirinus was a South-Gaulish potter of La Graufesenque and Montans (Déch. i, 84 and 136). Oswald and Pryce call him Flavian, while Knorr dates him A. D. 55-62. His stamps occur at Neuss (A. D. 25-105), at Corbridge three times in the Agricola period (*Corbridge*, 1909, 68), at Wroxeter three times in deposits dated A. D. 80-120 (*Wroxeter*, 1913, p. 35, and 1914, p. 56), and at Chester with other stamps and an as of Vespasian (A. D. 77-8). They have been found on several other British sites, including London, York, and Silchester (May, p. 230). Besides Drag. 18, he also made 18/31 and 33. There appears to be a second potter of the same name, who worked at Luxeuil and is dated by Fölzer in the middle of the second century.

C. I. L. xiii, 10010, 1152; ii, 4970, 268 a and 4972, 34 (Tarragona). Flavian.

93. (A) KVCAN\ 31. Orange-red glaze. Top soil.

Both the shape and the glaze exclude the possibility of this stamp belonging to the earlier Lucanus of Lezoux and Bregenz (dated also at Corbridge A. D. 90-105, *Corbridge*, 1912, p. 43). This example is of the Lucanus who started by making plain pottery at Heiligenberg in the middle of the second century (Forrer, xvi, 33, twenty examples) and later in the century moved to Rheinzabern, where he also made decorated bowls (Lud. i, 124; Reubel, p. 43; *Faimingen*, *O. R. L.* xxxv, p. 70). His stamp has also been found at Zugmantel (*O. R. L.* xxxii, p. 140, 187). In Britain it has been found at Silchester (May, p. 230) and London. Oswald and Pryce assign him to the Hadrian-Antonine period. He used Drag. shapes 31 and 33, Lud. Tq (= Dr. 18/31) and B (= Dr. 33/46).

C. I. L. xiii, 10010, 1164; Walters, M. 1975 and 2022 (on ? Drag. 32). Antonine.

94. (A) ANIOF = MANI OF(ficina). 33. Slightly domed base. Site III.

A little-known potter of South Gaul, who may be of Flavian date, as his stamp has been found at Banassac and Windisch. His ware has not previously been recorded on a British site (with the possible exception of /ANIOF on Drag. 29 from Kettering), nor an

exactly similar stamp from elsewhere. Mr. Atkinson suggests that all these stamps are made by a broken punch of GERMANVS.

C. I. L. xiii, 10010, 1260; xii, 5686, 529 (Fins d'Annecy); xv, 5311 (Rome). ? Flavian.

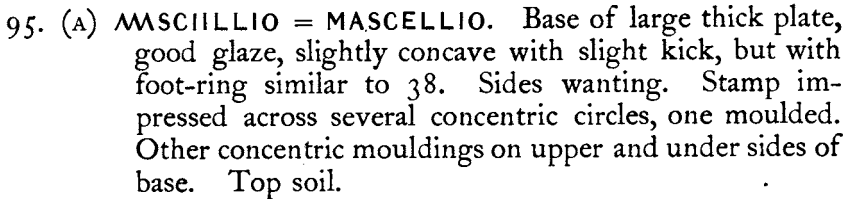
95. (A)  = MASCELLIO. Base of large thick plate, good glaze, slightly concave with slight kick, but with foot-ring similar to 38. Sides wanting. Stamp impressed across several concentric circles, one moulded. Other concentric mouldings on upper and under sides of base. Top soil.

Vessels with this name were made at Lezoux and Rheinzabern; a stamp on 33 was found at the Pudding Pan Rock. This is a common cognomen and there was probably more than one potter of this name. The Richborough example may well be earlier than the Antonine period and a stamp is recorded on 18/31 from South Shields. The stamp also occurs on 31, 32, and 33.



C. I. L. iii, 6010, 134; vii, 1336, 665; xiii, 10010, 1294; Lud. i, 54, iii, 42; *Proc. Soc. Ant.* xxii, 403.

96. (A) MERCATO/ 18.
 (B)  18, rouletted ring.
 (C) MER/ 18/31, thin, good matt glaze. } Top soil.

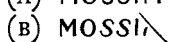
The first two probably belong to the Domitianic MERCATO of South Gaul, for whom see *Richborough* I, Dec. 5 (A), p. 57. In the case of the third it is impossible to conjecture; besides Mercato there are the two potters MERCATOR, from Lezoux and Heiligenberg respectively, both of whom worked in the second century, and the former probably in the reign of Domitian also. See Knorr *Rottweil* (pp. 35-6), Forrer (pp. 129-30), and *Wroxeter* (1912, p. 45); see also p. 69.

97. (A) MOSSIM 79. Top soil.
 (B)  18/31, within rouletted ring. Top soil.

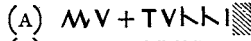
For Mossius or Moxius see no. 17 under the stamps on decorated Samian in this report (p. 65). The shape of the first stamp implies an Antonine date (cf. *Wroxeter*, 1912, p. 55—MOXIVSM); they both probably come from Lezoux.

98. (A)  33. Large, light brown glaze. Top soil.
 (B)  38. Brownish glaze. Chapel site.

Plain ware of Muxtullus has been found in the Allier district (*Coll. Antiq.* vi, 73) and is in the Plicque collection of Lezoux potters (*C. I. L.* xiii, 10010, 1398 e). Oswald and Pryce assign him to the Hadrian-Antonine period. His stamps are common in Britain, having occurred amongst other places at *Wroxeter* (1912, no. 80, p. 56; 'Gutter-find' 1924) Pan Sand

(*Arch. Cant.* xvii, 157), and Colchester on Drag. 81. He used Drag. shapes 18/31, 31, 33, 38 and 81 (and possibly 27, from Camelon).

C. I. L. xiii, 10010, 1398 ; vii, 1336, 744 ; xii, 5686, 618.

Hadrian-Antonine.

99. (A) PRIDIANI = PRIDIANI. 33, large, good glaze. Top soil.

Pridianus made plain pottery in East Gaul ; his stamps were found in a dated ditch at Saalburg (*O. R. L.*, *Stockstadt*, xxxiii, 104-6) and at Zugmantel (*O. R. L.*, p. 145), which points to the first half of the second century. Many have been discovered at forts on the Rhine, one at York and another is in the British Museum (Walters, M. 2151). He used Drag. 27, 31 and 33.

C. I. L. xiii, 10010, 1558.

Hadrianic.

100. (A) PRIMANI = PRIMANI. 33. Slightly domed, brown-red glaze. Site III, low level.

It is unlikely that this stamp belongs to the first-century potter Primanus (once from Neuss) or to the late second-century Rheinabern potter, found on the Limes, who signs PRIMANVS F(E) or PRIMANIVS FE (*Lud.* iii, 52, and iv, 51). It is probably a stamp of the better-known Lezoux potter of the late second century, who used the genitive frequently ; his signed vessels have been found at Pudding Pan Rock (*Proc. Soc. Ant.* xxii, p. 403) and commonly elsewhere in Britain (e. g. *Wroxeter*, 1912, no. 91 ; Kenchester, no. 26 ; and London, Walters, M. 1992, 2154-5). PRIMANIM also occurred twice in the Wroxeter 'Gutter-find', 1924 (A. D. 150-170).

C. I. L. xiii, 10010, 1560.

A. D. 150-90.

101. (A) QVINTI 33. Top soil.

There are three potters Quintus : the earliest worked at Montans in South Gaul (*Déch.* i, 84) his ware being found at Hofheim (A. D. 40-83), the Sels tilery (up to A. D. 40), the legionary camp of Neuss (ending A. D. 70), and the earlier period at Wiesbaden. He appears to have also made decorated bowls at Montans towards the end of the first century (*Déch.* i, 136, 295). A Quintus also worked at Lezoux in the middle of the second century (Allier district, *Coll. Antiq.* vi, 71). His ware is recorded from Pudding Pan Rock (A. D. 160-90) and Newstead (second century, Curle, nos. 76 and 77, p. 239). Oswald and Pryce (p. 63) call him a Hadrian-Antonine potter. There is also a third-century German potter, found at Niederbieber (Oelmann, p. 15), Niederberg (*O. R. L.*, p. 15), Rottweil (Knorr, 1907, p. 69, 309)

etc., who always used the nominative case. Of the two Gaulish potters (both common in Britain) it is suggested that the later uses the signature QVINTIM only, while the other signs QVIN, QVINT, or QVINTI. This distinction holds good of all stamps so far recorded, that can be dated certainly by their associations. This stamp, then, is tentatively assigned to the South-Gaulish potter, whose activity started under Claudius and probably continued into the reign of Vespasian.

C. I. L. xiii, 10010, 1607; ii, 6257, 159; vii, 1336, 893; xii, 5686, 725. *c. A. D.* 35-75 (?).

102. (A) ~~REBVRRI~~ QOI = REBVRRI OF(ficina). 33. Light brown glaze. Top soil.

This potter is to be distinguished from the South-Gaulish REBVRI, found at Montans and elsewhere (*C. I. L.* xiii, 10010, 1614 a-c). Reburrus appears to have been a Mid-Gaulish potter, from the distribution of his stamps, and is dated as Antonine at Wroxeter (*Report*, 1912, p. 58, on Drag. 79). His stamps are frequent on British sites (e.g. Walters, *M.* 2158-60 and 1994, and Corbridge, 1910, *Arch. Ael.* xii, p. 284). Besides Drag. 33 he also used 31, 32 or 38, and 79. A leaf or similar device is characteristic.

C. I. L. xiii, 10010, 1614; vii, 1336, 897; xii, 5686, 740. Antonine.

103. (A) REDITI•M 33. Top soil.

The site-dating for Reditus is: second period at Camelon (Pius) and at Wroxeter in an Antonine deposit (*Report*, 1912, p. 58). The stamp also occurred at Pfünz (*O. R. L.* 73, p. 50) and in Britain at Cirencester, Melbourne (Cams.), Caerwent, Colchester, Corbridge, Devizes, and London. He used Drag. 27, 31, and 33.

C. I. L. xiii, 10010, 1615; vii, 1336, 899; Walters, *M.* 1995 and 2161-2. Antonine.

104. (A) RIIGANI• = REGALI(S) 33. Large cup with dull glaze. Top soil.

The date of Regalis may be gauged from the occurrence of his ware at the following sites: Antonine period at Camelon; later period at Newstead (Curle, p. 239; A. D. 140-80); Gross Krotzenburg (*O. R. L.* xxiii, 32—up to the middle of the second century); Pfünz, with coin of Faustina I (*c.* 141); Welzheim, East Fort (time of Commodus, A. D. 180-92); and in graves 69 and 191 at Rheinzabern, with coins of Pius and Severus Alexander respectively (A. D. 140 and 230—Lud. iii, 154 and 178).

He probably worked at Rheinabern, as his stamps are very common there. In Britain his stamps have been found previously at Wroxeter (1912, p. 58), Silchester (May, p. 251), Corbridge (*Arch. Ael.* x, p. 284), Carlisle, Great Chesterford, and London (Walters, M. 2163; London Mus. A. 14721 and A. 16752 'Gaulish').

He used Drag. shapes 31, 32, 33, 40, 79, 80 and many Lud. variations. There is also a Gaulish potter Regalis, but the form and glaze preclude the possibility of this stamp belonging to him.

C. I. L. xiii, 10010, 1616; vii, 1336, 903; xii, 5686, 742.

Antonine, and possibly later.

105. (A) RECVL/ = REGVLVS 31. Dull glaze. Top soil.

Regulus is considered by Knorr to be a South-Gaulish potter of Domitianic date (*Rottweil*, 1907, p. 65). Possibly his activities extended rather later, as is suggested at Wroxeter (1913, p. 39, *q.v.*). His ware has been found at Corbridge, Great Chesters, London, and elsewhere in Britain; previously recorded only on Drag. shapes 18, 27, and 33.

C. I. L. xiii, 10010, 1621; vii, 1336, 918; xii, 5689, 744; Walters, M. 1808 and 2164.

c. A. D. 80-120.

106. (A) RITOGENIM 31. Top soil.

From the distribution of his stamps, Ritogenus was certainly a Gaulish and possibly a Mid-Gaulish potter of plain wares. At Wroxeter his stamp was found in the lowest level by Watling Street and dated thereby to A. D. 80-120 (*Report*, 1912, p. 59). But it has also occurred at Balmuilty, A. D. 140-70 (Miller, p. 72), and at other northern sites in Britain, York, Aldborough, Corbridge, Birrens, and Wilderspool. Besides Drag. 31, he also made 27.

C. I. L. xiii, 10010, 1640; vii, 1336, 922 (London) and 923 (Chesterford).

107. (A) ROPPV2-FEC 18 or 18/31, thin plate. Site III, 4 ft. down.

(B) ROPPV2•/ 18. Top soil.

A South-Gaulish potter, found at Hofheim (A. D. 40-83, Ritterling, p. 246), Neuss (*Bonn. Jahrb.* 111/12, 345), and Wroxeter in a late first and early second-century deposit (*Wroxeter*, 1913, p. 39, site 6). Oswald and Pryce assign him to the Nero-Flavian period. In Britain his ware has occurred at London, Cirencester, Corbridge (on 31), and Leicester. At Colchester his stamp occurs on what may be Drag. 29; otherwise he used shapes 18, 18/31, 27.

C. I. L. xiii, 10010, 1651; vii, 1336, 930; xii, 5686, 753; Walters, M. 1998 (on Drag. 31).

Chiefly Flavian.

108. (A) SANTIAND = SANTIANIŌ(fficina) Large concave base
(? 32). Top soil.

To judge from the distribution in *C.I.L.*, Santianus was a Gaulish potter, probably of the second century, as he is only recorded on Drag. shapes 31 and 33. His ware has been found in Britain at London, Cirencester, York, Corbridge (*Arch. Ael.* xii, p. 285), Caerwent (*Proc. Soc. Ant.* xxii, p. 409). This particular variation has not been noted previously.

C.I.L. xiii, 10010, 1719; Walters, M. 2000; cf. May, *Silchester*, p. 256.

109. (A) SECVNDINIM 18/31. Top soil.

This is the same potter of Lezoux who also made decorated bowls; see *Richborough* I (Dec. 8 A). As a maker of plain ware, he must be distinguished from two German potters of the second century, who worked at Heiligenburg and Rheinzabern respectively; the latter moved to Westerdorf in the middle of the century; both always signed in the nominative case. This Lezoux Secundinus used Drag. forms 18, 18/31, 27, 31, 33, and 37; his work is common on British sites.

First half of the second century.

110. (A) SEXTI•M 33. } Top soil.
(B) S•E[X]T/ 33. }

Several potters bear the name Sextus, to any of whom the incomplete stamp may belong. There was a South-Gaulish Domitianic potter, represented Drag. 29 at Neuss (*Bonn. Jahrb.* 111/2, p. 346) and on plain ware at Rottweil (Knorr, p. 66), who used the genitive and rarely the nominative with ligatured letters. There was an East-Gaulish potter (*C.I.L.* xiii, 10010, 1807; note the distribution) who signed SEXTVSF or FE (occasionally with a sloping initial S) and made Drag. 31 and 33. The common stamps SEXTIM or MA (? from Lezoux), have been found at Pudding Pan Rock (twice on Drag. 38; *Proc. Soc. Ant.* xxii, p. 268; A. D. 150-90) and on a large 27 at Pfünz (*O. R. L.* 73, p. 50). The name occurred frequently at Silchester (May, p. 261) and also on Drag. 79 at Wroxeter (*Wroxeter*, 1912, p. 61). Finally there was a Rheinzabern potter, who made decorated ware, signing SEXTVS.

C. I. L. xiii, 10010, 1807; iii, 6010, 210; 12014, 80.

111. (A)  OBNI•M = SVOBNI•M 31. Top soil.

Suobnus was found at Newstead—'second century, probably Antonine' (Curle, p. 241)—and on a few other British sites, where his name occurred on Drag. shapes 18/31, 27, and 31.

C. I. L. xiii, 10010, 1856 (where treated as identical with Suobnilli); Walters, M. 1898.

112. (A) $\overline{\text{TAVRICI}\cdot\text{F}}$ 18/31 or 31. Top soil.

Seven stamps, TAVRICI $\overline{\text{MA}}$ on Drag. 31, occurred in the 'Gutter-find' at Wroxeter in 1924, which implies that Tauicrus was a Lezoux potter of the middle of the second century. An exactly similar stamp to this was found at Pfünz (*O. R. L.* no. 73, p. 51) and two others of the same potter. Others have been recorded from Rottweil (Knorr, p. 68, 'Gaulish'), Silchester (May, p. 263), Wroxeter (*Wroxeter*, 1912, p. 62), Corbridge, and elsewhere. He made Drag. shapes 18/31, 31, and 33 (commonly).

C. I. L. xiii, 10010, 1894; vii, 1336, 1111; xii, 5686, 867.

Mid-second century.

113. (A) $\overline{\text{ERTIVSGFF}} = ?\text{TERTIVS G(aii) F(ilius) F(ecit)}$. 18.

Within rouletted ring, large heavy dish; tall letters.

Top soil.

There are at least two well-known potters of the name Tertius; one of La Graufesenque (*Déch.* i, 85) is of Nero-Flavian date, who made Drag. 18 normally though a stamp from Silchester is on 18/31 (May, 264). Some of his stamps also show TE ligatured. The East-Gaulish potter of La Madeleine is possibly identical with the Tertius of Rheinzaubern and worked in the last half of the second century. The glaze and manufacture of the Richborough example suggests a South-Gaulish provenance, but this stamp probably belongs to a potter to be distinguished from the above.

A similar stamp (read TERTIVSOFF) is recorded at Cirencester (*Cripps Mus. Guide*, p. 29) and two others in the Guildhall and Colchester museums are stamped on similar heavy dishes, probably of Neronian date.

Tertius: *C. I. L.* xiii, 10010, 1902, etc.; Walters, M. 752-4; Ritterling, *Hofheim*, p. 243.

114. (A) $\overline{\text{T}_1\text{T}/} = \overline{\text{TITVRONIS}}$ [O or $\overline{\text{OF}}$] 18/31. Rouletted ring.

Top soil.

Tituro was a Lezoux potter (Allier district: *Coll. Antiq.* vi, 74) of plain ware. His Drag. shapes elsewhere are 31, 32, 33, 79, and 80; his stamp occurs also in the London Mus. (A. 21092) on the Antonine bowl illustrated by May (*Silchester*, no. 43) and Curle (*Newstead*, no. 19), which falls between Drag. 38 and 44. Corroborating this evidence is the occurrence of his stamp in the 'Gutter-find' at Wroxeter in 1924 (A.D. 150-70). Another example was found at Paulton in association with objects of the late second century.

C. I. L. xiii, 10010, 1916; xii, 5686, 887; Walters, M. 1814 and 2188-90; *Wroxeter* 1912, p. 62.

A. D. 140-90.

115 (A) TOCCAF 27. Large cup, orange-red glaze. Found 4 ft. down, north of Chapel site.

Tocca was a maker of plain pottery only at Blickweiler, who flourished in the reigns of Hadrian and Pius, as may be seen from the site-dating of his stamps: the ditch of the Hadrianic earth-fort at Saalburg; at Praunheim with coins of Trajan and Hadrian (graves 222 and 70 respectively); at Stockstadt, first half of the second century (*O. R. L.* xxxiii, p. 106); at Cannstatt in the first period of the outer Limes (*O. R. L.* xxviii, p. 59); at Osterburken on the the Outer Limes, time of Pius (*O. R. L.* xl, 41, 39). His stamps occurred at Zugmantel (*O. R. L.*, p. 148, 342/7) and in several graves at Rheinzaubern (Lud. iii, 66, and iv, 62). He used forms 18/31 (= Lud. Tq), 27 (large), 31, 33, and 40.

C. I. L. xiii, 10010, 1921. Knorr, *B. und E.*, p. 110.

c. A. D. 120-60.

116. (A) VER~~CV~~CV = VERECV[ndus] 27. Twice stamped and blurred in centre. Top soil.

There are several potters of the name Verecundus:

(1) *South Gaul.* *C. I. L.* xiii, 10010, 2010, includes La Graufesenque and Montans; usual signature VERE, occasionally VERECV, on plain ware only. His stamps occurred in the early legionary camp of Neuss (ends A. D. 69) and in the second period at Hofheim, A. D. 74-83 (pp. 247-8 and note 300), where Ritterling states that this potter is *not* identical with that of Heiligenberg).

(2) *Lezoux.* One mould of Drag. 37, found there, is now in the Plicque collection (*Déch.* i, 302, no. 198), and Forrer quotes a second as from Lezoux (p. 132, fig. 55 a). There are also several stamps in *C. I. L.* from this district, all VERECVNDI. Possibly of Trajanic date.

(3) *Windisch.* A maker of Flavian decorated bowls of the name Verecundus had a kiln outside the west wall of the fortress (Forrer, p. 132).

(4) At least one *East-Gaulish* potter, dated to the first half of the second century by the presence of stamps at Saalburg in the earth-fort (A. D. 100-39) and at Stockstadt (*O. R. L.* xxxiii, A. D. 106-c. 120-60). Other stamps have been found at the following potteries: (a) *Itenweiler*, where Verecundus is believed to have been the principal maker of decorated bowls as well as of plain ware and mortaria (Drag. shapes 30 and 37, Forrer, p. 199-205); (b) *Heiligenberg*, where his name appeared on plain ware only (Knorr, *Rottweil*, p. 66-7: 57 examples), but decorated bowls, of a similar style to those signed VERECVNDVS at Windisch, were also found and are attributed to him (Forrer, p. 135).

(c) *Luxeuil*, *C. I. L. ibid.*, 2010 aa. Only on plain pottery, 'probably of the middle or second half of the second century' (Fölzer, p. 6, 7). (d) *Offemont*. About A. D. 120-60 (*Zugmantel*, pp. 149 and 156).

(e) *Blickweiler*. A. D. 100-150; 54 ex. (Knorr, *B. und E.* p. 110).

(5) *Rheinzabern*. Decorated bowls bearing his name have been found here; they are of a later style than the preceding and were made 'after the erection of the Outer Limes', i. e. second half of the second century (*Köngen*, *O. R. L.* xxx, pp. 55 and 79, and Reubel, p. 54-5). There were also five different readings of the name (including one Gaulish) on plain sigillata (Lud. i, 79 and 80, iii, 64 and 70).

Forrer (*Heiligenberg*, p. 140 *et seq.*) considers that all the stamps (except those from South Gaul, which he overlooks altogether) are assignable to one migratory potter, who started working at Lezoux about 85 and ended at Rheinzabern about A. D. 130. The question is confused by similarities of stamp or decoration from different sites (*Windisch*, figs. 55 *e* and *g* = *Ittenweiler*, figs. 240 *d* and *e*, and *Zugmantel*, no. 360 = Lud. iii. 70 *d*), but it seems on the whole to satisfy the evidence better to suggest the following conclusions:

i. A South-Gaulish potter of the second half of the first century.

ii. A Lezoux potter of the late first and early second centuries.

iii. A family of potters, who started at *Windisch* in Flavian times and worked at several East-Gaulish potteries well into the second century and later at *Rheinzabern*.

The Richborough stamp may most probably be assigned to the South-Gaulish potter (no. 1), as he alone appears to use this form of the name.

C. I. L. vii, 1336, 1157 and 1163; xii, 5686, 922; xiii, 10010, 2010.

ROSETTE STAMPS, ETC.

66. (B)  Concave base, poor light-red glaze. Top soil. West of site 3. Seven raised dots, from a circular punch (diam. $\frac{2}{5}$ in.).

Cf. on *Drag.* 32 (= Lud. Ta) two stamps from *Rheinzabern* (Lud. iii. 80, and iv. 72).

(c)  33. Large, nearly brick-red glaze (stamp $\frac{1}{2}$ in. in diam.). Top soil.

The two stamps comparable to this of ten small raised dots and one in the centre are much neater and more carefully made: cf. Knorr, *Rottweil*, p. 69, no. 320, and *Stockstadt*, *O. R. L.* xxxiii, p. 107, 162 (where only ten dots in all), the latter on *Drag.* 32.

- (D)  31. Within rouletted ring, brownish glaze.
Top soil. At least three-quarters of stamp preserved.

With this may be compared the narrow row of *vertical* hatched lines from Rheinzabern (Lud. iii, 83), also on 31.

Probably late second century.

As (B) and (C) appear to be degenerate in comparison with proper rosettes (e.g. *Wroxeter* 1912, p. 64), it is suggested that they are of third-century date rather than late in the second. For references and account see *Richborough* I, no. 66 A, p. 81.

STAMPS OF POTTERS THAT ALSO OCCURRED IN THE FIRST REPORT
(1922-3)

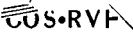
1. (B) \setminus OCISIO 33, small. West of site III, 4 ft. down.
2. (B) \wedge BUYFE = $\widehat{\text{ALBVS}}$ FE. Small thin convex base, good bright red glaze. West of site III, 4 ft. down.
3. (B) ANI \times I θ 33. Top level, north-east of platform.
5. (A) ARDA On slightly concave base, with small kick in centre. Top soil. Site III.
14. (B) [CEL]SI ω M 33. Site III. The 'leaf' occurs often on other sites.
18. (A) COSRVF 27.
 \setminus SRVF 27. Good glaze. } Top soil.
(B)  18.
22. (B) CV~~MI~~~~VS~~ 1' 31. Light red glaze. Top soil.
24. (B) DONTIOINI = DONTIO FEC Heavy base similar to 33, but with internal and external moulding near junction of side and base. Unstratified.
25. (A) DOVIICCV \setminus 31. Top soil.
27. (B) \setminus CIS 27. } Top soil. Probably one of the potters
(C) \setminus ICISF 27. Large. } FELIX, who often used this type of C.
29. (B) OFRONTI 18. Thin plate. } Top soil.
(C) \setminus ONTNI 18.
30. (B) GERMA 33. Very small, bright glaze. Top soil.
32. (C) OF IVCVN 18. Filling of inner ditch by E-W road.
36. (C) OF LICN Concave base, ?large Hofheim 6. Site III, low level.
38. (A) MACRINVS 31. Large (diam. 10 $\frac{3}{4}$ in.), stamped within rouletted ring. Site III.
Occurred three times in Wroxeter 'Gutter-find', 1924.
(A. D. 150-60.)

39. (B) MAS/ 18. Brilliant glaze. Top soil.
46. (D) /F PATRIC 27. } Top soil.
(E) /PATRIC 27. }
47. (B) \ /LLVS•FE. 79 (?). Top soil.
55. (B) OF.SA[INI] Quarter-round fillet plate, slightly convex.
Top soil.
(C) [S]ABIN 27. Top soil.
57. (B) SECV\ . 18/31. Site III, low level.
(C) OF•SECVND 27. West end of sec. 15, pl. XLVI, in burnt
layer. c. A. D. 100.
65. (G) VIIA 27. (? Stamp of Vitalis) }
(H) OF•VITA 27. } Top soil.
(I) OF VITA 27. }

UNCERTAIN, FRAGMENTARY, AND ILLEGIBLE STAMPS

MAAA 33. Top soil.

This can scarcely be a stamp of the pre-Flavian South-Gaulish potter Amandus, as no retrograde stamp is known. More probably this is a stamp that never was intended to be read as a name.

C•V•R•CX + (*retro*). 33. Brown glaze ; from the outer ditch, west of site III.

Compare the stamps of Curcus in *C. I. L.* xiii, 10010, 728 ; xii, 5686, 293, and Walters, M. 2091. CVR•CIMA occurs, but there is no record of a retrograde stamp of this rare potter.

/SSA. 79. From outer ditch, west of site III.

Cintussa, Cunissa, and Laxtucissa have not been recorded with flat-topped s as in this fragment, CARVSSA alone has (cf. 3 ex. in York Mus. and 1 in London Mus. A 20955). Moreover the latter is an Antonine potter (*Newstead*, p. 228) using Drag. 31, 33, 38, 79, and the Antonine variation of 38 (= May, *Silchester*, no. 43, and Curle no. 19). His stamps have occurred at Silchester (May, p. 211), Aldborough, Leicester, and Wroxeter (*Wroxeter*, 1912). He probably worked at or near Lezoux.

C. I. L. xiii, 10010, 466.

CRIS/ 33. Dull glaze ; from top soil west of site III.

This stamp may belong either to the La Graufesenque potter CRISPVS, whose stamps were found at Wiesbaden I, Neuss, Hofheim, and Newstead I, or to CRISPINVS. The former may be dated c. A. D. 60-90, and the latter in the second century, as his

stamp has been noted on Drag. 38 in the York Museum (*C. I. L.* vii, 1336, 573). Both use the form 33.

Crispus: *C. I. L.* xiii, 10010, 705; xv, 5162 (*Rome*).

Crispinus: *C. I. L.* xiii, 10010, 704; ii, 4970, 156, and 6257, 61.

/VRO 18/31. Top soil.

Possibly the end of a stamp of CRVCVRO, one of the latest South-Gaulish potters, contemporary with Biracil, Mercato, and L. Cosius, i. e. c. A. D. 80-110 (Atkinson, *Pompeii*, pp. 31-3). It is less likely to be a stamp of the Lezoux potter COCVRO, as there is only one example recorded of his name without F (*C. I. L.* vii, 1336, 330).

ΣFY/ 18. Good glaze; top soil. Unassignable.

GII/ Flat base, 18 or 79. Top soil.

This is probably one of the two potters GEMINVS; either the first-century potter of Lezoux who signs in the nominative case, or the Antonine potter, GEMINIMA, for whom see no. 87 (p. 78).

IVLIIIN/ 31. Top soil.

This much-worn stamp should probably be read as a variety of IVLIANVS, a Rheinzabern potter of the second century.

MA . . . VS F 33. Top soil.

This may be a stamp of one of the potters MATERNVS.

/ATO 18. Within rouletted ring; top soil.

This is likely to be part of a stamp of the South-Gaulish potter MERCATO (c. A. D. 80-110); cf. D. 5 A, and no. 96 (p. 80).

//////(?) ? = MVRLLI Large 33. Light red; much rubbed. Uncertain reading, no parallel recorded.

PACATV ? = PACATV 33. Top soil.

There are two potters of the name Pacatus, one who worked in central Gaul at the turn of the first and second centuries (*Corbridge*, 1912), and the second whose stamp was found with a coin of Hadrian in a grave at Rheinzabern (*Lud.* iii. 48). Both sign their vessels sometimes PACATV F, but from Rheinzabern come also two stamps PACATV (one retrograde; *Lud.* i, 62 and 63).

C. I. L. xiii, 10010, 1485.

/IMI ? = OF PRIMI 27. Top soil.

There at least two potters of the name Primus. This stamp may be assigned to the Nero-Flavian potter of La Graufesenque (*Hofheim*, *Wiesbaden*, *Neuss*, *Sels*, *Rottweil* on 29 of Vespasianic date, and *Wroxeter*, 1912, A. D. 80-90, and 1913, A. D. 80-120).

C. I. L. xiii, 10010, 1569; and *Richborough I*, no. 50 (A. D. 75-85).

/ITIM 33. Top soil.

Several potters' names have this termination.

RF/ Lud. Tg, fine glaze. Unassignable.

R19V (retro) or VP1Я 33 (small early type). Good glaze; top soil.

This is a complete stamp, easily legible. The shape precludes the possibility of attributing it to the second-century potter RIPANVS, who worked at Heiligenberg. The cup is $1\frac{1}{2}$ in. high, $1\frac{9}{16}$ diam. inside at base, and $4\frac{1}{8}$ diam. outside at rim.

OFS1/ 18. Dull glaze; top soil. Unassignable.

OFVER/ 18 or 18/31. Coarse lettering; found in top layer west of site III.

This might be a stamp of the pre-Flavian potter VERVS (Sels and Neuss, camp) who sometimes signed OF VERI. Otherwise, it is to be assigned to one of the Gaulish potters named Verecundus (cf. no. 116, p. 86) who occasionally use the stamp OF VERE. No other potter beginning VE appears to have been recorded with the prefix OF.

(V)(NTIL)(A) (*sic*). 33. Top soil.

Complete stamp; almost certain reading, but no parallel can be found.

(VIX) 27. Top soil.

Complete stamp, badly struck. Possibly another freak stamp of ANEXTLATVS.

11/1 33. Top soil.

Small, neat, and (apparently) complete stamp.

/NTM. Slightly concave base of dish, with rouletted ring; large letters. Top soil.

NICI~~////////////////~~OK 27, mis-struck. Top soil.

This is very doubtfully assigned to Nicephor, but the length of the stamp and the terminal letter seem to make it unlikely.

/~~////////////////~~LISM 27, worn. Top soil. Unassignable.

/SFECl 79, neat letters. Top soil.

∩. Thin plate, slightly concave. Part of circular stamp. Top soil.

There remain seventeen stamps, which are either completely illegible or consist of only one or two letters, not worth recording, on Drag. 18 (3), 27 (8, two certainly first century), 31 (5) and 38.

STAMPS ON IMITATION SAMIAN (LATE RED-COATED WARE)

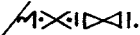
1. (A)  Base as Drag. 18/31, with rouletted ring. Found in the top soil, north-east corner.
2. (B)  On similar base. Found near the fort wall in north-east corner.

STAMP ON LAMP

2. (A) FORTIS. Stamp on under side of base within two concentric circles. The lamp, of pale buff colour, is of a usual simple type, unornamented (pl. xxv, no. 84, and p. 97).

The sites on which this potter's lamps have been found indicate that his period of activity continued into the beginning of the second century. He probably worked at Mutina in North Italy (*Guide to Antiquities of Roman Britain in British Museum*, 1922, p. 46).

Cf. *C. I. L.* xiii, 10001, 136. Montans, Windisch, and 46 others.
 iii, 6003, 25. Rhaetia, Pannonia, 40 exx.
 vii, 1332, 15. Brit. Mus., Cambridge Mus., York, Caerleon, Aldborough.
 xii, 5682. Gallia Narb.
 xv, 6450. Rome, 40 exx.

Guildhall M. Cat., p. 46, nos. 27, 28.

Neuss, *Bonn. Jahrb.* III/12, p. 364.

Pfünz, *O. R. L.* xiv, p. 60, 203.

Gr-Krotzenburg, *O. R. L.* no. 23, p. 37.

Wiesbaden, *O. R. L.* xxxi, p. 121.

Faimingen, *O. R. L.* xxxv, p. 105 (6 exx.).

Chester, *Rept. on Roman Potters' Marks*, Hayter, *Chester Arch. Soc. Journ.* xxvi, 1.

Fortis was certainly at work before A.D. 80 for his lamps have been found at Pompeii (Atkinson, *Pompeii*, p. 27). In the Pompeii Hoard his wares occurred in association with those of the lamp-maker COMMVNIS, whose work has been found at Hofheim (p. 269) in the period A.D. 74-83. Loeschcke (*Keramische Funde in Haliern*, p. 212) dates the origin of this class of lamp—the so-called 'Firmalampe'—about A.D. 75.

STAMPS ON AMPHORAE

11. (A)

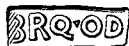

Very small lettering, stamped downwards on handle. Site III. Top soil.

= BROQ() OD(VCIAE).

Cf. *C. I. L.* xii, 5683, 44, BRO·ODV (St. Germain Museum); xiii, 10002, 12, BROCODV (10 ex.); xv, 2736, *id.* Rome (5 ex.). May, *Silchester*, p. 282, 49, /ODV. Cf. also *C. I. L.* xv, 3058, PORODV (= Portus Oduciae) 3 ex.; ODV 'fortasse componendum est cum Oducia oppido in conventu Hispalensi sito' (cf. *C. I. L.* ii, p. 137 and 1056, 1182). Oducia is therefore a town situated in the district of Hispalis, i.e. modern Seville. The provenance of the stamp, like that of many others, is the Roman province of Baetica.

12. (A)



Stamped downwards on centre of shoulder of a long handle. Second and third letters uncertain; QEF or QEE possible, or even QF_ΔE. Found in the top soil.

Cf. *Corbridge Report*, 1911, p. 61, 35, QFE.

13. (A)



Stamped downwards on left side of a short handle. Also a fragment of another similar stamp. Both found in clearing the top soil.

Cf. *C. I. L.* ii, 6254, 22 (Baetica, Spain, which probably shows its provenance); xiii, 10002, 277, 3 ex. (German sites); xv, 2947, 13 ex. (Rome), of which several come from east side of Monte Testaccio and are therefore not later than the reign of Pius. May, *Silchester*, p. 280, 21, 22; *Corbridge Report*, 1908, p. 115; 1911, p. 60, 24; Housesteads, in Black Gate Museum, Newcastle-on-Tyne.

14. (A)



Block lettering stamped diagonally upwards on a longish handle. Found in the top soil, in the north-west angle of fort.

Cf. *C. I. L.* xiii, 10002, 387 (Vechten); xv, 3073 (Monte Testaccio).

15. (A)



Block lettering stamped downwards on a longish handle. Top soil.

= G() L() PVĎĒ(NTIS).

Cf. *C. I. L.* xii, 5683, 67 (Orange); xiii, 10002, 306 (Rouen Museum); xv, 2983 a (Monte Testaccio, Or. $\frac{1}{4}$, II $\frac{1}{2}$, III $\frac{1}{2}$, 3 ex.). A quarter of the way up the hill on east

side means, at very latest, not later than Pius (A. D. 138-161) and probably earlier. *Colchester Mus. Report*, 1914, p. 10.

16. (A)



Block lettering, stamped downwards on left side. Found in the top soil.

Cf. *C. I. L.* xiii, 10002, 52 (Ober-Florstadt in Castello); xv, 2626 e (Monte

Testaccio). *Wroxeter*, 1914, p. 59, 34, SCA · V . . .

Possibly a shortened form of the following: *C. I. L.* xiii, 10002, 48 a, ^SCAENSA · G · ME, Trion (2 ex.); 48 e, ^SCAENSN/, Windisch (a first-century site); xv, 2626 a, SCA · ESEN, Rome; xv, 2619, SCAENSA · EME (= Scalensia Gemelli?). Mommsen, rather doubtfully, suggests that Scalensia is synonymous with testacea (bricks or tiles).

17. (A)



Small lettering, stamped downwards on right side of grooved handle. Found in clearing the surface soil.

Cf. *C. I. L.* xiii, 10002, 293 a, b, ^{IVLI} SOSIMI

Trion (Lyon M.), and Wiesbaden (Mus.).

18. (A)



Block lettering stamped downwards on right side near top of a thin, straight handle. Found in the top soil.

Cf. *C. I. L.* xiii, 10002, 534, VRSI, VRS~~Y~~; xv, 3247, a, VRSI 2 ex., b, ~~Y~~VRSI (Monte Testaccio).

STAMP ON AMPHORA ALREADY RECORDED IN 1922-1923

1. (B) /QVIETI Block lettering stamped downwards on left side of handle. Found in the top soil, in the north-west angle of fort.

Additional references: May, *Silchester*, p. 278, 4, pl. LXXX B, 4 ANQ fragmentary. Wheeler, *Brecon*, p. 246, 1, 2; no. 2 was found in an early second-century deposit with the sigillata stamp ROPPIRVTI · M. *C. I. L.* x, 8049, CATQ, Pompeii; xiii, 31111, QVET, Rome (complete stamp). The finding of this stamp at Pompeii shows that the potter must also have been at work in the first century A. D.

STAMPS ON MORTARIA (PELVES)

8. (A)



= ALBINVS.

On Wroxeter mortarium type 18, dated in first century A. D. Pipe-clay ware, white grit. Found in the top soil.

Cf. *Guildhall Mus. Cat.*, p. 102, 616, 618, 620; p. 103 (3 ex.). No. 618 with LVGV DV shows the potter

worked at Lyons. *Chester Arch. Soc. Journ.*, xxvi, 1, p. 32, no. 1. *Colchester Mus. Report*, 1913, p. 31, stamp on reddish ware with buff slip; 1924, p. 15. May, *Silchester*, p. 275, 1, 2. *Wroxeter*, 1912-13-14, five stamps on types 34 and 38; two of these were dated by site to A.D. 80-110 and 80-120. Wheeler, *Segontium*, p. 150 (found outside the fort, 1920, ALBINV on Wroxeter type 38). Walters, *B. M. Cat.*, M. 2766-70 (ALBINI), 2771 (ALBINVL).

9. (A)



= GRATV[S] reversed.

Probably on Wroxeter mortarium type 18, of first century A.D. Yellowish buff, white grit, exterior ribbed. Found in the top soil.

Cf. *C. I. L.* xiii, 10006, 37, GRATVS (Toulon, Angers Mus.). *Newstead*, p. 266, 10, 11, GRATV, GRAT/. May, *Templebrough*, p. 120, 5, GRA/. Miller, *Balmuildy*, p. 78, 6, GRATI/, on Wroxeter type 58 (nearly), second century A.D., probably first half.

10. (A)



Stamped diagonally, grey ware, pale bluish-white surface, mixed grit in flange. Probably on Wroxeter mortarium type 54, found there in a deposit of A.D. 80-120 Site III.

Cf. *C. I. L.* vii, 1334, LVGVDI · F (London), i. e. LVGV DVNI · FACTVM.

11. (A)

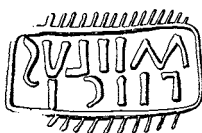

= MELVS FECI[T].

On no. 157, pl. xxxi. Found in the top soil.

Cf. *Wroxeter*, 1912, p. 66, 9, MELV, mid second century. Walters, *B. M.*

Cat., M. 2791-2, London.

12. (A)



= MONV . .

On Wroxeter mortarium type 58, late first and first half of second century A.D. Pink slip on coarse red ware, some white grit. Found in the top soil.

Cf. *Chester Arch. Soc. Journ.*, xxvi, 1, p. 39, 11, ΝΑΛΟΝΤ. *Newstead*, p. 266, 16, ΜΟΙΗΝ, ΛΟΙΗΜ (probably Antonine).

STAMPS ON MORTARIA ALREADY RECORDED IN 1922-1923

- I. (A) Stamped on a shape between Wroxeter mortaria types 14 and 18, of first century date. Pinkish pipe-clay ware, mixed grit. Found in clearing the top soil.

2. (B)  On Wroxeter mortarium type 18, dated in first century A.D. Pale yellow buff. Found in clearing the top soil.
5. (A) On Wroxeter mortarium type 14, dated in first century A.D. Pale yellowish buff with pink core, white grit. Top soil, site III.
7. Herring-bone or conventional leaf pattern. Pale yellowish buff, white grit. On Miller, *Balmuildy*, type 32 (Antonine), flange with flat end. Four feet down, south-west of site III.

GRAFFITI (pl. xxxv, fig. 2)

1. CARATICV[S, on form 18, of good glaze and paste. The period of the plate is probably Nero-Vespasian. The lettering is scratched on the outside of the base immediately above the footstand. Found in the top soil west of site III.
2. MARCIANI, on form 36, which may be dated to the 'turn' of the first and second centuries. Lettering on the outside of the wall. Found in the top soil west of site III.
3. VER[, on form 33, of second century date. Lettering on the outside of the wall. The complete name is possibly VERECVNDVS (cf. Walters, *B. M. Cat.*, M. 677). Found in the top soil.
4. SENECA. Scratched on a brick before baking (pl. xii, fig. 2). Found in clearing the top soil.

The following note is by Mr. R. G. Collingwood, F.S.A. :

The *cognomen*, which is not common, seems to be generally associated with a Spanish origin. The cases of its occurrence given in the *Prosopographia Imperii Romani* may be summarized as follows : (i) Annaeus Seneca of Corduba, born a few years before the death of Cicero. (ii) L. Annaeus Seneca, the famous man of letters, his son. (iii) A contemporary of (ii), disparagingly mentioned by him. (iv) M. Calpurnius Seneca, connected with various places in Spain, and in command of the fleet at Misenum in A. D. 134. (v) — Seneca, governor of Lycia and Pamphylia under Hadrian. (vi) Cn. Coelius Seneca, whose father or grandfather is mentioned in an inscription of A. D. 244. The name thus occurs from the beginning of the Imperial age to the late third century ; nor is there anything in the style of the Richborough graffito to suggest a closer dating.

5. OVINĒI·EI·ILII////. On a thin strip of bronze $2\frac{1}{2}$ in. by $\frac{1}{4}$ in. by $\frac{1}{16}$ in. broken at both ends. Found in clearing the top soil.

The reading of this inscription is by Mr. R. G. Collingwood, F.S.A. The letters are much worn, especially at the top, and some shown as I may be T. The first letter is incomplete and might be D, Q, or O.

LAMPS

Pl. xxv, no. 84. Lamp of pale buff clay with long grooved nozzle and two knobs on the rim. Handle broken. The stamp FORTIS on the base. See p. 92. Found in clearing the top soil.

Walters, *Lamps*, type 93, and pl. xxvii, 907, first century. *O. R. L.* xxxvi, Ems, pl. III, 11; xvii, Arnsburg, pl. III, 31, Domitian-Trajan; xxxi, Wiesbaden, p. 121, fig. 15.

Pl. xxv, no. 85. Oval lamp with knob handle and decorated on the rim with a spiral scroll. Found in clearing the top soil.

Walters, *Lamps*, type 107, and pl. xxxvi, 1329, and pp. 199-203; late or quasi-Christian type. Cf. *Richborough I*, pl. xix, 6; late fourth century.

Pl. xxv, no. 86. Circular lamp with moulded rim and slightly projecting nozzle. Found in clearing the top soil.

Walters, *Lamps*, type 106, and pl. xxxii, 1203; third-century type.

THE COARSE WARE

(Plates xxix-xxxv)

Fragments of coarse-ware vessels were again found in great numbers, the majority belonging to types already well known. The almost entire lack of stratified deposits and closely dated groups has prevented much new or useful information being obtained, and there is little that can be added to the remarks made in the first Report. Large quantities of the late red-coated and other closely allied wares dealt with at some length in that report (p. 89) were found in clearing the top soil, thus affording additional evidence of their late date. When this ware first came into general use is still uncertain, but it is a significant fact that pit 26 (p. 33) in which were found upwards of 140 coins, none apparently later than the close of the third century, did not contain a single fragment of one of these vessels. It would seem that practically all the commoner types of this ware were published in the first Report as it has only been found possible to add a few new ones, most of which appear to be rare examples.

During the four years' excavations many fragments of ollae or cooking pots with the outside surface furrowed with a bunch of

twigs or a comb have been met with, and typical examples may be seen on pl. xxix.

This ware is common at Richborough in the Claudian deposits, and although it continued in vogue into the second half of the first century it would seem to have ceased to be made before the close of the Flavian period. It is native and not Roman in origin, and its immediate prototypes can be seen in the examples from Aylesford and Swarling, Kent (*Arch.* vol. liii, pl. viii, 8, pl. ix, 6; *Swarling Report*, pl. ix, 31). Unpublished examples have also recently been found in the same county at Ramsgate, Walmer, and Worth near Sandwich, while there are others in the Maidstone Museum from various Kentish sites. In Essex it occurs on several pre-Roman sites, and in the Colchester Museum are examples from Lexden, Braintree, Shoebury, and Maldon. There is also a fragment from Plesheybury which was found in association with pre-Roman objects (*Essex Arch. Soc. Trans.* xiv, N.S., p. 231, pl. iii). As far as can be ascertained, no examples have been discovered in Essex on purely Roman sites and the vessels do not as a rule have bead rims but are generally of the recurved variety.

Outside Kent and Essex this ware seldom occurs, but examples have been found at Hambleden, Bucks., (*Arch.* lxxi, 181, no. 173); near Newport Pagnell, Bucks., in association with La Tène III pottery and now in the Aylesbury Museum; at Hauxton, Cambs. (Fox, *Arch. of the Cambridge Region*, 96); and also at Margidunum, Notts., in a well of the Claudian period (*J. R. S.*, vol. xiii, pl. x, 7).

It will be seen, therefore, that the principal district where this ware is found is that represented by Kent and Essex, and as it is often associated with pottery of the Aylesford-Swarling series there can be little doubt that it was introduced into this country by the Belgic invaders who overran this area in the last century B. C. (*Swarling Report*, p. 38).

This particular type of ware is common on the Continent where its origin is also in the pre-Roman period. It is found throughout South Germany and Bohemia during the La Tène period (*Déch. Manuel*, pt. 3, p. 1483; *Allertümer uns. heid. Vorzeit*, v, 937, pl. 51, from the cemetery of Steinbichel near Manching, Bavaria, and at Hofheim in an incineration grave 50-1 B. C., Ritterling, *Hofheim*, p. 393, fig. 109, 5, grave 9). It survives the Roman conquest, and is common on early Roman sites in Germany, occurring at Xanten in the Augustan period (*Bonn. Jahr.*, Heft 119, p. 279, type 1, and Heft 122, p. 380, pl. lv, 4, 5); at Neuss in an Augustan grave group (*Bonn. Jahr.*, Heft. 111/12, pl. xx, grave 1, p. 313), at Haltern (Loeschcke, *Mitteilungen für Westfalen*, v, p. 29,

type 91 A, pl. xxv, 9), and at Windisch and early sites on the Lower Rhine. It appears to have gradually disappeared under Roman influence and is not found at Hofheim in the period A.D. 39-51. In Rhaetia, in which province no Roman legion was quartered and where in consequence native influences survived, it occurs at Faimingen which was not occupied until the latter part of the first century A.D. It also continued in use in this province into the second century in the small civil settlements but has not been found in the Roman city of Regensburg (*O. R. L.* xxxv, pp. 87-8, pl. xi, 27).

The carefully executed wheel-made horizontal rilling was probably derived in the first instance from the rough and irregular combing or furrowing. Both types occur in pre-Roman times, occasionally in close association as at Swarling. Illustrations of vessels with the regular rilling may be seen in the *Hengistbury Head Report*, pl. xxvi, 9-11; the *Swarling Report*, pl. ix, 22; and in *Sussex Arch. Coll.* pl. v, lxxv, 22, from Slinfold. At Richborough the regular rilling has been noted on vessels of late third or fourth century date.

135. Olla with bead-rim separated from the body by a groove and ledge. The exterior is furrowed vertically (pl. xxix, fig. 1). Black to brown clay coated with brownish slip and wheel turned. Pit 20. 27-28 ft. down. Claudian.

Compare no. 136. See pp. 97-9.

136. Bead-rim Olla. The exterior is furrowed, the upper part horizontally, the lower vertically (cf. pl. xxix, fig. 2, nos. 4, 5). The base is flat and pierced with three holes. Hand-made, black to brown unwashed clay coated with smooth slip. Pit 20. 22-24 ft. down. Claudian.

Compare nos. 21, *Richborough I*, and no. 135 of this Report. See pp. 97-9.

137. Mouth of flagon with four-ribbed rectangularly bent handle. Well-moulded oblique-sided undercut rim. Fine hard cream-coloured clay. Pit 20. 24-25 ft. down. Claudian.

Compare no. 66, *Richborough I*; Ritterling, *Hofheim*, pl. xxxiv, 50 B; and Xanten, Augustan period, *Bonn. Jahr.*, Heft 122, Taf. 52, no. 18.

138. Mouth of flagon with oblique sided and undercut rim. Red clay. Pit 20. 22-24 ft. down. Claudian.

This belongs to the same class as no. 137.

139. Flagon with corrugated mouth and short neck. An offset at the junction of neck and body. White to pinkish clay. Pit 20. 6 ft. down. Probably Flavian.

Compare nos. 34 and 35 of *Richborough I*.

140. Bowl of poor, rough workmanship with curved side and

plain upright rim. Grey to dirty brown clay with smoothed outside surface. Pit 20. 26-28 ft. down. Claudian.

Cf. Ritterling, *Hofheim*, pl. xxxvii, 115.

141. Upper part of mortarium. Hard cream-coloured clay, the top of the flange and the whole of the inner surface studded with fine white quartz particles. Pit 20. 12 ft. down. Claudian or possibly Nero-early Flavian.

142. Beaker with small outbent rim, an offset at the junction of neck and body. Two decorative zones of roulette hatching, one below and the other above the bulge, which is burnished. Black varnished, hard, fumed, grey clay. A late example of the butt-shaped beaker. Found in the filling of the outer ditch west of site III.

Cf. *Swarling Report*, pl. ix, 34; *Wroxeter*, 1914, pl. xxvii, no. 71; *Arch. Cant.* xxxvii, p. 35, pl. xi, 86, from Ospringe.

143. Upper part of flagon with moulded and slightly undercut mouth and two-ribbed handle. Hard light brown clay. Site III, low level. First-century type and probably Claudian.

Compare *Richborough I*, nos. 67-69.

144. Olla with outcurved rim, a raised band or corrugation on the shoulder, a girth-groove on the bulge with a zone of oblique rows of roulette hatching below. A slightly raised and moulded base. Found in the top soil, but probably of first-century date.

Cf. Lambert, *Arch.* lxvi, p. 250, fig. 15, no. 19, A.D. 70-100, from London.

145. Jug or flagon with pinched mouth. Pale drab clay. Site III, low level in association with first-century pottery.

Cf. May, *Silchester*, p. 145, pl. lxii, 115.

146. Candlestick of hard sandy buff clay. Found in the top soil. Probably late third or fourth century.

Cf. *Ashley Rails*, pl. xii, nos. 5, 7; May, *Silchester*, p. 111, pl. xlvi B; *Wroxeter*, 1912 fig. 18, 41-43.

147. Upper part of olla with slightly curved oblique rim, wide topped and angle moulded on the inner edge. Hard unwashed fumed grey clay, irregular in thickness, but showing marks of wheel turning on the outer surface. Found in the top soil.

Cf. May, *York Pottery*, p. 90, pl. xxi c, 13; Collingwood, *Ambleside*, 1914, p. 51, fig. 23, 68, third or fourth century; Margidunum, *J. R. S.* xvi, pl. vi, 10 and 31, third century.

148. Flagon with two-ribbed handle and four-ribbed mouth. Buff clay. West of site III in a deposit assigned to A.D. 150-200.

Compare no. 72, *Richborough I*. A very similar example

occurred at Ospringe in a group dated *c.* 200, *Arch. Cant.* xxxvii, p. 45, pl. xv, 129.

149. Olla with outcurved lip, high shoulder, wide bulge, and broad base. Brown clay coated with smooth pasty slip. Hand-made, uneven, and very heavy for its size. Found in surface clearing west of site I. This is the common type of late cooking-pot at Richborough, fragments of many examples having been found in the top soil.

Compare no. 57, *Richborough I.*

150. Castor-ware cover perforated in the centre of handle-nob, and decorated with rows of roulette hatching. Pale buff clay with brown slip. Top soil.

Cf. May, *York Pottery*, p. 43, pl. xi, 9.

151. Upright side of dish with heavily moulded rim and bevelled base. Hard fumed brown to grey clay with black varnished surface. Site III, low level and probably of first-century date.

Cf. Corbridge, *Arch. Ael.*, ser. 3, vol. viii, p. 170, pl. xi, 10; A. D. 90-110.

152. Cheese-squeeze with nearly upright side pierced at intervals as is also the base, which has a conical centre encircled by a raised beaded moulding. Hard clay, partly fumed grey and partly reddened by heat. Pit 18, with a coin of Claudius Gothicus, A. D. 268-70.

Cf. May, *York Pottery*, p. 96, pl. xxii, 20; *Arch.* lxxii, p. 238, fig. 7, 61, 62 from Sandford; *Wroxeter*, 1912, fig. 18, 38, Antonine.

153. Bowl with thickened overhanging rim. Hard, fumed, pale silver-grey clay. From the filling of the inner ditch south of site III.

154. Straight-sided dish with bevelled base. A wavy scored line round the outside. Grey clay, black polished. In the filling of the inner ditch south of site III.

Cf. May, *Silchester*, p. 161, pl. LXVI, no. 202.

155. Bowl on tripod. Coarse hard clay fumed grey. Site III.

Tripod bowls are common in the La Tène III period in Gaul, and also occur in the first century on various sites, but are not met with after that date in any quantity.

Cf. May, *Silchester*, p. 118, pl. XLIX, no. 68; *Arch.*, lxi, p. 210, fig. 6; Bulliot, *Mont Beuvray*, pl. xxvi, no. 17; Ritterling, *Hofheim*, p. 321, pl. xxxv, type 90.

156. Dish of finely-polished, fumed, grey clay with black varnish. A double girth groove below the lip, and bevelled foot. In the filling of outer ditch, and not later than the third century.

157. Mortarium of hard clay, pale buff to cream colour, the

inside studded with white and brown quartz particles. The stamp no. 11 across the rim. See p. 95.

158. Dish with upright side, and moulding below the rim. The side decorated with a zone of wavy lines. Dirty light brown smooth clay. Found in the top soil.

159. Dish with groove on inside edge of rim. White clay painted with orange-red slip on the inner margin of the base, and in vertical stripes on the inside wall. Found in the top soil.

160. Angular-sided bowl with girth-grooves on the lip and angle. Pale brown sandy and flaky clay. Found in the top soil.

Cf. *Wroxeter*, 1912, fig. 17, no. 7; late first or early second century.

161. Fragment of plate with moulded base. Pale brown clay, coated inside and to half an inch below the lip on the outside with dull rich red slip. Unstratified, but several fragments of this ware have been found in first-century deposits.

162. Fragment of carinated bowl with moulded lip and mouldings on side. Dirty white clay with the mouldings and upper side of lip coated with reddish-brown paint. The lower part restored from other examples. Found in clearing the surface soil. Probably late third or fourth century.

Cf. *Arch.*, lxxii, p. 236, fig. 5, 25, from Sandford; May, *Silchester*, p. 127, pl. LV, 4; Wheeler, *Segontium*, p. 165, fig. 72, no. 34, assigned to the latter part of the third century, or possibly half a century later.

163. Neck of flagon with a pronounced moulded neck-ring and plain mouth. A three-ribbed handle. Red clay, fumed brown-grey inside and coated with cream slip outside. Found in the filling of outer ditch west of site III, and therefore probably not later than the third century.

Cf. *Ashley Rails*, pl. IX, nos. 1, 2, 11-13; Sandford, *Arch.*, lxxii, p. 235, fig. 2, no. 19; fig. 5, no. 22; Ospringe, *Arch. Cant.*, xxxvii, viii, 55, pl. XII, 92.

The occurrence of this type of mouth at Niederbieber (Oelman, ii, 43, 46, iii, 63) indicates that it was in vogue by the middle of the third century. Several of this type with slight variations were found in clearing the top 3 ft. (see nos. 164-5).

164. Neck of flagon with neck-ring and moulded mouth. Reddish-brown clay, scarlet slip. Found in clearing the top soil, and probably of late third- or fourth-century date.

See nos. 163, 165.

Cf. *Hengistbury Head*, pl. xxv, no. 7; *Arch. Cant.*, xxxvii, pl. VIII, 61; Wheeler, *Segontium*, fig. 78, no. 49, assigned to the end of the third century; Fox, *Archaeology of the Cambridge Region*, pl. xxv, 2.

165. Neck of flagon with moulded neck-ring and two girth-grooves beneath the lip. Light reddish-brown clay with traces of scarlet slip. Found in clearing the top soil, and probably of late third or fourth-century date.

See nos. 163-4.

166. Neck of flagon with moulded overhanging lip and two-ribbed handle. Offset at junction of neck and body. White clay. Found in the top soil. Probably late third or fourth century.

Cf. May, *Silchester*, p. 166, pl. LXVIII, 148; *Ashley Rails*, pl. IX, nos. 6, 9; *Sloden and Black Heath Meadow*, pl. VIII, no. 2.

167. Small dish or cup with slightly curved side and girth-groove below lip. Fumed pale grey clay burnished on the inside and lip. Owners mark N scratched on the outside. Found in clearing the top soil. Probably late third or fourth century.

Compare no. 88, *Richborough I*.

168. Small cup or dish with slightly curved side and a girth-groove below the lip. Bright-red clay with grey core and darker red slip. Found in clearing the top soil. Probably late third or fourth century.

169. Body fragment of wide bulged vessel of uncertain type, possibly a flagon. Hard, dense, flaky clay, with smooth surface of brown colour mottled with black. The wall decreases in thickness towards the mouth. Decorated with bosses pressed out from inside and with small indented rings. Found among the ruins of the hypocaust of the late bath building, site III, and probably belongs to the end of the fourth century or later.

170. Flanged bowl imitating the Samian form 38. Pale red clay coated with mottled brown red to pale red slip imitating marble. Fragments of several of these bowls were found, but none in stratified deposits. Their find-spots suggest, however, that this type is probably not earlier than the third century.

Cf. *Ashley Rails*, pl. VII, nos. 5, 6.

171. Variation of nos. 107 and 115, *Richborough I*. Hard dull red clay with grey core coated with dark red slip. Decorated on the outside of rim with scrolls and vertical rows of dabs in white slip. Found in association with coins of the fourth century.

172, 173. Cups, possibly imitations of the Samian form Ludovici Tf. Dull hard red clay with red smooth matt surface. Found in the top soil. Probably late third or fourth century.

174. Portion of large dish or bowl, imitating the Samian form Ludovici Tk. Hard light red clay with scarlet slip. Found in the top soil. Probably late third or fourth century.

Cf. *Arch.* lxxii, p. 228, fig. 1, 5, from Sandford.

175. Variation of no. 114, *Richborough I*, decorated on the rim

with a pattern in white paint in imitation of the barbotine designs on the Samian forms 35 and 36. Grey clay with red slip. Found in the top soil. Probably late third or fourth century.

Cf. May, *Silchester*, p. 126, pl. LIV, 96, and p. 154, pl. LXV, 139. See nos. 176-7.

176. Variation of no. 114, *Richborough I*, imitating the Samian form 35. Decorated on the rim with a pattern consisting of curves and lines in white paint. Hard flaky red clay with brown slip, apparently burnt. Found in the top soil. Probably late third or fourth century.

See nos. 175, 177.

177. Variety of no. 114, *Richborough I*, imitating Samian form 36. Decorated on the rim with a pattern consisting of dots and strokes in white paint. Hard tile-red clay with dark red slip. Found in surface clearing. Probably late third or fourth century.

Cf. nos. 175-6; cf. *Ashley Rails*, p. 23, pl. IV, no. 4.

178. Bowl imitating the Samian form 36. Hard fumed grey clay. Found in the top soil. Probably late third or fourth century.

Cf. the red-coated examples, nos. 175-7.

179. Lower part of vase with slightly raised base and heavily moulded foot-ring. Hard smooth dull red clay. Found in the top soil. Probably late third or fourth century.

180. Very similar to last and of the same clay and colour. Found in the top soil. Probably late third or fourth century.

181. Lower part of upright-sided vase or beaker with pedestal. Hard light red clay with scarlet slip. Found in the top soil. Probably late third or fourth century. The reconstruction is based on an example in the Joslin Collection, no. 212, group $\frac{105}{35}$, in the Colchester Museum, which is of similar clay with scroll ornamentation in white paint.

182. Lower portion of vase or beaker of similar type to the last, but with more angular foot and with two rows of roulette hatching on the lower angle of side. Hard pale red clay with bright pinkish-red slip. Found in top soil. Probably late third or fourth century.

183. Bowl of no. 104, *Richborough I*, with bands of roulette hatching on the inside. Hard light red clay with red slip. Found in the top soil. Probably late third or fourth century.

Cf. Wheeler, *Segontium*, fig. 78, no. 57, fourth century, and fig. 75, no. 18; probably c. A. D. 350.

184. Upper part of flagon with mouth in the form of a human head. Hard whitish clay painted with narrow zones of red ochre. Found in the top soil. Probably third or fourth century.

185. Beaker with high neck and moulded rim. Conjectural restoration of base. Decoration on the body of dogs chasing hares

en barbotine. Hard light brown clay with a dark dirty brown slip or wash on the outside and to a depth of about one inch inside the lip. In pit 26, 18–22 ft. down. Fragments of several similar vessels were found in this pit, which was filled in towards the end of the third century A.D.

Cf. May, *Silchester*, pl. LII; *Arch.* lxxii, p. 229, fig. 2, no. 16, p. 231, fig. 3, nos. A, B, C, D, third or fourth century, from Sandford; *Bonn. Jahr.*, Heft 114/15, pl. 25, Cologne grave 62. Thought to be of third-century date by Poppelreuter.

Pl. xxxv, fig. 1. Upper portion of Castor ware beaker decorated with a lion *en barbotine*. Light-coloured clay with dark blue-grey slip. Second-century type. Site III.

Pl. xxv, no. 83. Pottery jug-neck of yellow-brown clay. Top soil. The elaborate head-dress is unusual, but jug-necks decorated with human heads are not uncommon on Roman sites. Behn (*Römische Keramik*, pl. VI, 3, no. 798 and 1328, F 75) illustrates a complete example from the Worms potteries. The output from these potteries is mainly of Constantinian date.

NOTE ON THE CLAY-STONE SLAB (p. 31)

Dr. H. H. Thomas, F.R.S., reports that this is a finely-laminated pale greenish-grey clay-stone of marine origin; non-calcareous for the most part but with local marly films and pockets. The smaller specimen is of the same material. It is difficult to say whether it originally had a nodular form or not. The green colouration is due to vivianite (phosphate of iron), probably formed naturally from the secondary oxidized iron ore strongly developed on one side of the specimen. It is apparently not a British rock and was probably introduced from abroad.

THE COINS

I. COINS FROM THE SURFACE CLEARING

By F. S. SALISBURY

The coins, to the end of the Roman series, described in the following list number 16,825 and are all derived from the interior of the Fort of Richborough. A preliminary classification of a large number of pieces by Mr. A. G. K. Hayter and Mr. J. W. E. Pearce considerably lightened the work of describing that part of the finds. There are also incorporated in this list 1,460 pieces found in the summer excavation of 1924-1925 and described by Mr. J. W. E. Pearce, which are indicated by a starred serial number in the margin if only occurring in the coins dealt with by him, and by a starred number in the text if they are identical with types in the surface finds. But the greater part of the coins are from the top three feet of that part of the enclosed area from which the surface layer has so far been cleared.

The two Greek pieces were determined by Mr. E. S. G. Robinson, and the British and Gaulish money by Mr. G. C. Brooke. The latter has also identified the medieval and modern coins, and is solely responsible for the description of the Anglo-Saxon finds which follow the Roman list.

The whole of my work on the surface-finds has been done in the Department of Coins and Medals at the British Museum, and I am indebted to Mr. H. Mattingly for help and advice on numberless occasions. My debt to him has been particularly great in dealing with the worn and intermittent coinage of the first two centuries.

On the money of Carausius and Allectus I owe valuable comments to Mr. Percy Webb.

A very large proportion of the Roman series belongs to the middle and latter part of the fourth century; and the second half of the third, from Gallienus and the Gallic usurpers to Carausius, is well represented.

The surface layer also yielded a scattered coinage going back to Republican times. But its amount is relatively small, and on the other hand the lower levels, whose numismatic yield is described along with surface coins by Mr. Hayter in *Richborough I*, and by Mr. Pearce in the account incorporated with the present list, also show a large number of late fourth-century coins. No doubt the distinction between the horizons has been partly

obliterated by the peculiar character of the site. Without springs of fresh water, and cut off by tidal marshes from those of the mainland, the inhabitants of ancient Richborough were compelled, like the beleaguered Pompeians at Ilerda, to get all their water from wells :

puteusque cavati
montis ad irrigui premitur fastigia campi.
Lucan IV, 295-6.

At Richborough the soil is chiefly sand and the wells often silted and fouled. Mr. Bushe-Fox's account of the many already cleared shows how great must have been the vertical circulation of material and consequently of small objects like coins contained in it.

A greatly reduced occupation is assumed for many British sites between the end of the first and the middle of the third centuries, owing to the small numismatic yield during that period. Richborough is no exception in this respect, and especially in the first half of the third century, which is almost a blank. In view of the position of Richborough, independently of any military post stationed there, it is likely that the explanation of this absence of coinage is merely fiscal and economic.

The following table shows in the first column the coins found during the winter clearing of the surface soil, which was removed on an average to a depth of 3 ft. In the second are the coins found in the summer excavations which, although carried down to the lowest occupation levels, did not involve the examination of nearly so much soil. In the third column is the total.

	Surface clearing.	Summer ex- cavations of 1924-5.	Totals.
GREEK	2		2
GAULISH	2		2
BRITISH	4		4
ROMAN			
Republic	3	1	4
Augustus	2	1	3
Agrippa	1	2	3
Tiberius	4	1	5
Caligula	2		2
Claudius I	17	22	39
Nero Drusus		4	4
Antonia	1	1	2
Nero	5	2	7
Galba (?)	1		1
Vitellius	1		1

108 REPORTS OF THE SOCIETY OF ANTIQUARIES

	Surface clearing.	Summer ex- cavations of 1924-5.	Totals.
Vespasian	17	12	29
Titus	5		5
Domitian	15	3	18
Nerva	2	2	4
Trajan	9	1	10
Hadrian	9	2	11
Sabina	1		1
Antoninus Pius	11	7	18
Faustina I	2	1	3
Marcus Aurelius	3	1	4
Faustina II	6	3	9
Annia Lucilla	3		3
Commodus	2	2	4
Crispina		1	1
First and second century <i>Æ</i>	2		2
” ” ” <i>Æ</i>	11	3	14
Septimius Severus	3	1	4
Julia Domna	2		2
Caracalla	1	1	2
Plautilla		1	1
Julia Maesa		1	1
Severus Alexander	3		3
Julia Mamaea		1	1
Gordian III	2		2
Philip I		1	1
Trebonianus Gallus	1		1
Volusian	1		1
Valerian sen.	2		2
Gallienus	111	18	129
Salonina	5	2	7
Saloninus	1		1
Valerian jun.	1		1
Postumus	21	5	26
Laelian		1	1
Victorinus	93	13	106
Marius	2		2
Claudius II	110	16	126
” consecration coins	121	22	143
Quintillus	2		2
Tetricus I	397	77	474
Victorinus or Tetricus I	3	4	7

	Surface clearing.	Summer ex- cavations of 1924-5.	Totals.
Tetricus II	90	37	127
Radiates, unassigned	338	178	516
Aurelian	4		4
Severina	1		1
Tacitus	6		6
Probus	6	1	7
Diocletian	3	1	4
Maximian	9	2	11
Carausius	268	44	312
Allectus	45	14	59
Constantius I	6	1	7
Helena	81	13	94
Theodora	60	4	64
Galerius	3		3
Maximin II	1		1
Maxentius	1		1
Licinius sen.	11		11
Licinius jun.	3		3
Constantine I	171	20	191
Constantinopolis	381	42	423
Urbs Roma	298	23	321
Pop. Romanus	14	2	16
Fausta	2		2
Crispus	16	3	19
Delmatius	3	1	4
Constantine II	170	22	192
Constantius II	330	21	351
Constans	343	32	375
Constantius II or Constans	632	47	679
House of Constantine, un- attributed	567	45	612
Magnentius	59	2	61
Decentius	5		5
Magnentius or Decentius	2		2
? Constantius Gallus	2		2
Julian	15	2	17
Helena (wife of Julian)	1		1
Jovian	3		3
[Carausius II	1		1]
Valentinian I	184	8	192
Valens	202	23	225

110 REPORTS OF THE SOCIETY OF ANTIQUARIES

	Surface clearing.	Summer excavations of 1924-5.	Totals.
Gratian	185	8	193
House of Valentinian I, unattributed	277	20	297
Unassigned 3 ^d <i>Æ</i> , late third century to <i>circa</i> A.D. 383	348		348
Valentinian II	521	39	560
Theodosius I	571	44	615
Aelia Flaccilla	2		2
Magnus Maximus	106	8	114
Victor	41	1	42
Magnus or Victor	20	3	23
Eugenius	42		42
Arcadius	1602	107	1709
Honorius	325	20	345
House of Theodosius, unattributed	5961	386	6347
Constantine III	1		1
? Pavunius	1		1
	<hr/> 15,365	1,460	16,825

The questions on which the Richborough coins may be expected to throw some light are both historical and numismatic. Their significance for the history of the site itself, when they are found associated with other remains, belongs to the description of the structures excavated. The chief subjects I shall refer to here are:

- (i) The date of the Roman evacuation of Britain.
- (ii) Mints of the House of Valentinian.
- (iii) Mints of the House of Theodosius.

The field to be covered is wide, but it has been possible to discuss some of the principal questions in separate papers elsewhere, and to these more detailed studies reference is made.

i. *The Roman Evacuation*

The outstanding feature of the Richborough money is the great increase in the volume of the coinage down to the last issues of the Gallic mints, about A.D. 395. In the west and midlands of Britain the coinage is most plentiful in the Constantine period, and descends thereafter in a progressively attenuated stream, reaching vanishing-point at the period when at Richborough the finds are most plentiful.

TABLE I

[This table is based on the coins from all levels published in both the First and Second Reports on Richborough]

House of Constantine

<i>Circa</i> A. D. 320-337	.	.	.	1532 about
„ „ 337-364	.	.	.	1963 „

House of Valentinian

Valentinian I	A. D. 364-375	.	.	232
Valens	„ 364-378	.	.	272
Gratian	„ 367-383	.	.	230
Unassigned	„ 364-383	.	.	343

House of Theodosius(A. D. 383-*circa* 395)

Valentinian II	.	.	.	664
Theodosius I	.	.	.	744
Magnus Maximus and Victor	.	.	.	195
Eugenius	.	.	.	42
Arcadius	.	.	.	1900
Honorius	.	.	.	399
Unassigned	.	.	.	7548 about ¹

The facts are fully discussed in the *Antiquaries Journal* (vii, 270 ff.), where the conclusion is drawn that Britain was finally cut off from Roman control by A. D. 410 at latest, and that the west and much of the midlands were probably lost before 400. Evidence is there quoted from the Bourne river valley (Cyril Fox, *Archaeology of the Cambridge Region*, p. 226) which suggests that the area retained by the Romans after 400 extended to a strip of the eastern counties under the protection of the forts of the Saxon Shore. That is supported by the high proportion of siliquae of Arcadius and Honorius contained in the Icklingham silver hoard² and still more strikingly by a find in the same locality of over a thousand late copper pieces recently examined by Mr. J. W. E. Pearce.³ They show the same preponderance of the latest money as do the coins of Richborough. We have yet to discover more nearly where the uncertain frontier of the retained area runs. Probably

¹ This figure includes the unassigned coins of both Reports. The 543 coins under 3 Æ Q in *Richborough I*, p. 109, include Constantinian pieces of reduced module, and a reduction has accordingly been made based on the proportions of the 3 Æ Q coins of the two periods in the present Report.

² G. F. Hill, *Num. Chron.*, 1908, 215.

³ Not yet published.

the sparsely occupied and wild region that lay between the civilized areas of the future East Anglia and the Severn valley was as free from the inroads of plunderers as it was from settlements worth plundering. The result we reach is that the larger part of Britain lost by Rome before A.D. 400 was overwhelmed not by Saxon invaders, except in the north-east, but by raids of Picts and Scots (see Ridgeway, *J. R. S.* xiv, pp. 123 ff.).

The following table (II), based on the whole of the coins included in this Report, displays the preponderance after 364 of the mints of Arles and Lyon over that of Trèves, and the small proportion of the money of Honorius. It is shown (*Ant. Journ.*, vii, *loc. cit.*), that these results are inconsistent with either (a) a date for the closure of the Gallic mints much later than A.D. 395, or (b) the view, based on the *Notitia Dignitatum* and on Mr. Foord's theory of coin drift, that the Roman occupation was prolonged far into the fifth century.

TABLE II
Analysis of Mint-Marks

	Arles.	Lyon.	Arles or Lyon.	Trèves.	Aquileia.	Milan.	Rome.	Siscia.	Constantinople.	Cyzicus.	Heracleia.	Nicomedia.	Thessalonica.	Antioch.	Alexandria.
<i>House of Valentinian.</i>															
Valentinian I . . .	52	19	15	4	13		10	18							
Valens . . .	68	33	13	6	19		17	6			1			1	
Gratian . . .	57	28	5	2	3		3	—			1				
Unassigned . . .	15	12	9	2	—		2	1							2
<i>House of Theodosius.</i>															
Valentinian II . . .	93	31		4	34		26	1	4					1	1
Theodosius I . . .	84	25		11	51		45	2	2	8		1*	1		
Magnus . . .	34	13		7	8		5								
Victor . . .	8	6		2	6	1									
Eugenius . . .	—	4		4	3		2								
Arcadius . . .	262	106		32	68		16			2	1	1		2	
Honorius . . .	38	12		4	10	3	6								
Unassigned . . .	262	132		60	77		67			1				3	
<i>Totals</i> . . .	973	421	42	138	292	4	199	28	6	10	2	4	2	7	2

* Aelia Flaccilla.

The absence of Arles from the mints of Eugenius appears not to be accidental. He held Trèves, Lyon, and Aquileia, but perhaps never secured the Mediterranean port.

ii. *Mints of the House of Valentinian I*

Aq = Aquileia. Ar = Arles. L = Lyon. R = Rome.

Valentinian I.

	Type I. <i>Gloria Romanorum.</i>				Type II. <i>Securitas Reipublicae.</i>			
	OF I*	OF II	OF III	OF IV	OF I	OF II	OF III	OF IV
Aq .	4	1				3		
Ar .	5	3	5		18	4	7	
L .	1	16			2			
Ar or L		8						
R .	1				4	1	2	2
Valens .	2				6	7		
Aq .	5	3	3		20	8	7	
Ar .		2			24	2		
L .					7	2		
Ar or L	1			1	5	1	4	2
R .								

* The officinal marks OF I-IV only occur in the field of part of the coinage of Arles and Lugdunum under the House of Valentinian I. The remainder of the coinage of these two mints and all the issues of other mints have an officinal *letter* in the exergue only.

The distribution of the coinage of the two emperors under each type is very similar at Rome and Arles, but there the resemblance ceases. Valentinian I apparently struck about equal quantities of GLORIA ROMANORVM and SECURITAS REIPUBLICAE, so far as we can judge from the Gallic mints, but, since the latter type has twelve Italian marks (9 R + 3 Aq) against six (1 R + 5 Aq) of the former type, its output was perhaps greater in Italy. It has been shown (*Num. Chron.*, 1927, 113 ff.) how large a currency a small number of Italian mint-marks found in Britain may represent. In Gaul Valentinian struck Type I chiefly at L II, and Type II chiefly at Ar I.

Valens, on the other hand, struck four times as much of Type II as of Type I. Even allowing for this the Italian coins of Type II are commoner than those of Type I from the same mints (12 R + 13 Aq to 2 R + 2 Aq), but the disproportion (3:2) is not so great as under Valentinian (2:1).

Valens strikes the larger part of his Gallic Type II in Ar I and L I. The two emperors therefore share Lyon, though curiously OF I is used by Valens. The marks which may belong either to Arles or Lyon are distributed for both emperors in the same way as those of Lyon. But Ar I is used equally by both colleagues, and the work of the other two officinae is not equalized by their

Type I issues. Probably Type II is the later and Valens strikes in Ar I after the death of his senior (see, however, a further employment of Ar II and III under Gratian). The mint-marks of their other types are too few to take into account.

Gratian (all types except late VOTA)

	OF I	OF II	OF III	
Aq .	2	1		His VOT XV MVL T XX would give us 5 Ar I + 1 Ar III and 5 L I, but should belong, as the first officinae indicate, to his last period after the death of his two colleagues.
Ar .	5	11	26	
L .	9	7		
Ar or L .	3	2		
R .	1			

The Arles marks of Gratian go a long way with those of his colleagues to equalize the work of the three officinae, and might be taken by themselves to express his gradual ascent from the third to the first place in the Empire, but the occupation by Valens of L I with Valentinian in L II makes the assignment of officinae by seniority less certain at Arles also. Since L I and L II are occupied by his two seniors, Gratian's coinage at Lyon is divided about equally between the two officinae.

The work of the officinae in the only two mints which offer adequate data is thus approximately accounted for in this period.

iii. *Mints of the House of Theodosius*¹

An analysis of the distribution (*a*) among emperors, (*b*) among mints, of the three principal bronze types of the House of Theodosius shows that all of them were struck by Valentinian II, but the Two Victories type came to an end before the accession of Honorius.

VICTORIA AVGGG with one Victory is western and predominantly Gallic.

VICTORIA AVGGG with two Victories is western and predominantly Italian.

SALVS REIPVBLICAE is universal but predominantly eastern and Italian.

Comparison with four Egyptian hoards described by Mr. J. G. Milne² confirms these results in every particular.

The great predominance of Arcadius in the Gallic but not in the Italian mints (Table II) indicates that, under Stilicho's tutelage,

¹ I have given detailed tables and a fuller discussion of the subjects of this section in *Num. Chron.*, 1927, 113 ff., but analyses of the officinae are printed here only.

² *Num. Chron.*, 1926, pp. 77 ff.

he was nominal ruler of the Three Gauls, at all events until the elevation of Honorius.

The mintmarks of the *Two Victories* types with legend VICTORIA AVGGG are insufficient to yield any results. The *One Victory* type (I 1651-2410) gives the following figures for Arles and Lyon :

Arles (Type 1651-2410)

	OF I	OF II	OF III
Valentinian II . . .	68	5	4
Theodosius I . . .	12	38	6
Arcadius	45	30	96
Honorius	4	—	16

The distribution in the main is according to seniority. The complete exclusion of any Augustus from all but his normal officina is not to be expected and perhaps was deliberately avoided. Valentinian II, however, keeps closely to OF I. Similarly Theodosius has OF II. But he was senior Augustus from A.D. 392 to 395 and therefore appears in OF I. Yet not as frequently as we should expect until we take into account the position of Arcadius, above referred to, as nominal governor of the three Gauls ; or perhaps of the whole west except Rome, if we explain in that way the extension to Aquileia also of his Gallic preponderance near Theodosius. By virtue of this position Arcadius strikes freely in OF I as well as in OF II. The latter also belonged to him by order of seniority on the death of Valentinian II, in A.D. 392. Yet the chief part of his money comes from OF III in accordance with his place as third partner in the empire for the four years preceding that date (Arcadius had been Augustus for nine years before the death of Valentinian II, but Arles was in the hands of Maximus until 388). The small output of Honorius from OF I may express the prolongation of the activity of Arles after the death of Theodosius ; but the proportion of only twenty-five per cent. to his issue as junior Augustus from OF III between A.D. 393 and 395 is additional proof that the period was very short.

Lyon (Type 1651-2410)

	OF I	OF II
Valentinian II . . .	17	2
Theodosius I . . .	16	1
Arcadius	80	—
Honorius	4	—

I have suggested elsewhere (*Num. Chron.*, 1927, 118) that there was a progressive southward retirement of the Gallic mint organization, and a gradual withdrawal of the coinage of bronze to Arles, first at the expense of Trèves and then of Lyon, which struck in two officinae from Valentinian I to Gratian, and was reduced to one officina as early as 388. From 383 to 388 it was in the hands of Magnus Maximus, who struck in two officinae. The figures of the Lyon table again display the Gallic predominance of Arcadius.

The *Salus Reipublicae* type only gives adequate figures for Aquileia and Rome.

Aquileia

	OF I	OF II
Valentinian II . . .	12	10
Theodosius I . . .	16	25
Arcadius . . .	42	18
Honorius . . .	3	4

Valentinian II divides his coinage impartially. Theodosius as his junior uses OF II, and as his successor after 392 he comes into OF I also. Arcadius curiously has a predominance like that which he enjoys in Gaul.

Rome

	OF I	OF II	OF III	OF IV	OF V
Valentinian II . . .	15	1			
Theodosius . . .	2	2	10	6	
Arcadius . . .	3		1	1	2
Honorius . . .	4				

The Italian superiority of Theodosius over Arcadius is asserted only at Rome. Valentinian II holds the chief place as senior in OF I. Arcadius and Honorius are both admitted to the first officina, and it is possible that, both here and in Gaul, Valentinian may have readily repaid to the child, who could not be his rival, some part of the gratitude due to the support of Theodosius; or the latter may have accepted for his heir a prominence he was too politic or too loyal to claim for himself.

By a further analysis of the two main types of the House of Theodosius we reach the following results :

G = Gallic mint-marks. I = Italian (and Eastern) marks.

*Salus Reipublicae**Victoria Auggg*

		G.	I.			G.	I.
Valentinian II . . .	232	? 1	50	290	123	? 2	
Theodosius . . .	235	—	70	302	116	? 3	
Arcadius . . .	362	? 1	77	1286	395	? 6	
Honorius . . .	116	? 3	14	214	50	? 1	
House of Theodosius	2555	? 9	127	3533	444	? 4	
Totals . . .	3500	? 14	338	5625	1128	? 16	

The Grovely Wood bronze hoard shows the two types exclusively confined to Italy (with the East) and to Gaul respectively. Those few readings which have been assigned here to the other geographical area are in all cases doubtful.

Of the two types together there are thus 9,125 coins yielding 1,142 Gallic and 354 Italian (with a few Eastern) mint-marks. Assuming the average condition to be the same, we should expect the Gallic coins to be in the proportion of almost exactly 3 : 1. But the condition of the two series is very different and the actual proportion nearer 2 : 1. More than one-fifth of the Victoria type (mainly Gallic) furnish legible mint-marks as compared with just over one-ninth of the Salus series (mainly Italian). Similarly, as the above table shows, a smaller proportion of Salus coins are assignable to emperors. This suggests that much of the Italian bronze had been longer in circulation than the Gallic before it arrived at Richborough. But it supports also a further conclusion. The Salus type continued to be struck in Italy and the East after the cessation of the Victory series and the closure about A. D. 395 of the Gallic mints. Any coins, therefore, which arrived at Richborough between that year and 407 were mainly of the Salus type. But they were comparatively few, otherwise they would have raised the average legibility of the series, and it would have compared more favourably in this respect with the Victory coinage. The same inequality of condition tells against the possibility of a prolonged use of the whole mass of this late money on the site.

Possibly a period of coin drift for a part of the coinage is thus indicated. But it was by no means so long as the comparative legibility (9 : 5 about) of the Gallic and Italian series at first sight suggests. The table given shows that the main volume of Victoria coins did not begin till after the elevation of Arcadius, and this issue

118 REPORTS OF THE SOCIETY OF ANTIQUARIES

must be still further delayed till the recovery of the Gallic mints from Magnus in 388. The bulk of this type, therefore, was not merely less remote in place of origin, but also more recent in date, and the whole difference in legibility may thus be accounted for.

II. COINS FOUND IN THE SUMMER EXCAVATIONS, 1924-5

By J. W. E. PEARCE

The general character of the coins and their numbers as representative of the various periods of the Roman occupation bear out the remarks made by Mr. Hayter in the first Report. The 'radiate' are the worst preserved, their corroded and brittle condition being due apparently to burning in some catastrophe which happened shortly after the reign of Carausius. Pit 26 yielded 138 coins, almost all of this description. In every layer identifiable radiate coins were found. Among the unidentifiable remainder (listed below as 'probably radiate' but not counted in the percentage analysis) were many which from their general appearance suggest Carausius.

The decipherable coins of the two years together give the following percentages :

Period.	No. of Coins.	Percentage of Total.
First century, 14-98 A.D.	50	3.9
Second century, 98-193 "	18	1.4
Third century, 193-253 "	6	0.5
" 253-306 "	353	27.8
Fourth century, 306-64 "	279	21.9
" 364-83 "	59	4.6
" 383- "	506	39.9

The first half of the third century and the first thirty years of the fourth are again very sparsely represented. The last century and a half of the occupation provides over ninety-four per cent. of the total coinage. At the lower levels now reached, the radiate types naturally are becoming increasingly more numerous than the Theodosian. To take the two years separately—in 1924 the radiate are fourteen per cent., the Theodosian fifty-five per cent.; in 1925 the radiate are forty-two per cent., the Theodosian twenty-four per cent. The period A.D. 330-364 has twenty-one per cent. in each year.

Two small 'hoards' were found—one in 1924 consisting of 74 3ÆQ, of which 61 were identifiable. Of these fifty-four were Theodosian (one barbarous), while the other seven were all sub-

sequent to A. D. 340 (p. 26). The second group was found with the remains of a brass bound box in the filling of pit 20 (p. 31). It consisted of 16 sestertii (nos. 2517-28 and 2556-9), badly corroded but otherwise in mint condition, all dating (to judge from the absence of PP in the style) from the early years of Claudius I.

No fresh light is thrown by the present list on the date of the Roman evacuation of Britain. But several of the coins are quite interesting; some from their comparative rarity as the Laelianus (no. 2892), the Crispus with horse on the *obv.* (no. 5943), and the Carausius with *obv.* bust, in imperial mantle, l. (no. 4610), his legionary coin with *rev.* ram standing, l.; some from their showing unpublished variations in the *obv.* legend, as two of Vespasian (nos. 2580 and 2582-3) with common reverses; some, as of Carausius (no. 4645) and Allectus (no. 4767), with new varieties in the combination of legend and mint marks, and some, especially among the barbarous or semi-barbarous coins, from individual peculiarities in the treatment of the type imitated.

My best thanks are due to Mr. H. Mattingly for his help in the identification of doubtful coins, and to Mr. P. H. Webb for his valuable notes on the mint marks and the dating of the coins of Carausius and Allectus.

The following list, compiled by Mr. Salisbury, includes both the coins found in the surface clearing, identified by him, and those from the summer excavations identified by Mr. Pearce, the latter being indicated by a star as noted on p. 106. The numbering is continued from the last Report; I followed by a numeral refers to coins in that list again occurring.

Greek

Cyzicus

2492. *Obv.* Bust of Athena helmeted r.
Rev. Head and neck of bull l., trident, KYII. Second century B.C. B. M. C. 159. Æ.

? *Massilia*

2493. *Obv.* Head.
Rev. Bull butting r.

Gaulish

Senones

2494. *Obv.* Two goats erect and fronting one another. Between them a dot.
Rev. Wolf and boar fronting one another. Border of dots on both faces within a raised edge. Muret et

Charbouillet, *Monnaies Gauloises*, 7449 foll. Muret says the type of two goats appears to be imitated from bronze money of Amphipolis and Thessalonica. Cp. *B. M. C.*, Amphipolis, 36-9, on *rev.* of which two goats are fighting.

2495. *Obv.* Beardless head r.
Rev. ? Horse l. Gaulish attribution uncertain.

British

Cunobelinus, King of the Trinobantes, 5 B.C. to c. A.D. 43.

2496. *Obv.* C]A—M. Ear of bearded corn.
Rev. CVNÖ. Horse galloping r.
Copper core for plated gold coin, cp. Evans, xiii, 3, who says, 'I have some hesitation as to engraving these among the copper coins, as I am convinced that they are merely ancient counterfeits of those in gold. Taylor Combe, p. 14, no. 8, mentions one as having been formerly gilt, and with the gold still adhering in places.' The bronze of our coin is very yellow, but Dr. A. Scott, who has kindly tested it, reports that no trace of gold or gilding can be detected.
2497. *Obv.* Bust to r.
Rev. Bull to r. Rosette with dot in middle over bull.

Uncertain Attribution.

2498. *Obv.* Boar l. with high crest. Part of wreath above. Below the boar a ring surrounding a pellet: similar smaller ring and pellet at tail.
Rev. Horse l., ring ornament above, below  between traces of ring ornaments.
2499. 'Tin' coin, Evans, pp. 123-6 and pl. H.

Roman

REPUBLIC

Lucius Papius (c. 80 B.C.)

2500. *Obv.* Head of Juno Sospita r., wearing goat's skin tied under the chin; behind, a symbol.
Rev. [L PAPI] in exergue. Gryphon galloping r.; beneath, a symbol.
Papius is a moneyer only known to us by his coins. *B. M. C.* 2977 foll.
Denarius.

? *Pomponius Musa* (c. 68 B.C.)

- *2501. *Obv.* Head (? Apollo) r.
Rev. Illegible. Draped female figure l.
 Denarius.

C. Serueilius C. Filius (c. 63 B.C.)

2502. *Obv.* Head of Flora r. bound with wreath [of flowers, wearing necklace of pendants, and earring in shape of cross]; hair collected into a knot [which is decorated with jewels; string of pearls at back of head]; before FLORA . PRIMVS (Floralia primus [fecit]); behind, lituus.
Rev. [C SEREIL C F in exergue and field]. Two warriors armed with shields standing facing each other; [in their r. hands they hold their swords, with hilts touching; the boss of the shield of the warrior on the r. is ornamented with a star of five points]. Grueber *B. M. C.* 3816. *Æ*.

Unclassified

2503. Denarius. Ex ? R]O [MA .

EMPIRE

Augustus (30 B.C.—A.D. 14)

- *2504. *Obv.* DIVVS AVGVSTVS. Radiate head of Augustus l. between S C.
Rev. CONSENSV SENAT ET EQ ORDIN P Q R. Augustus seated l., holding olive branch in r. hand; l. arm on chair.
 Cohen 87. M. and S., Caligula, p. 120. A.D. 37-41
 Dupondius.
2505. *Obv.* DIVVS AVGVSTVS PATER. Radiate head l.
Rev. PROVIDENT. Altar between S C.
 Cohen 228. M. and S. I, p. 95, no. 6, struck under Tiberius. As.
2506. Attribution uncertain. *Æ*2, countermarked.

Agrippa (d. 12 B.C.)

- 2507-9. (= 19). 2*.

Tiberius (A. D. 14-37)

2510-11. *Obv.* TI CAESAR DIVI AVG F AVGVSTVS. Laureate head r.

Rev. PONTIF MAXIM. Livia (?) seated r. holding branch. Cohen 16. M. and S. 3. Denarius. 1*.

2512. *Obv.* TI]CAESAR AVGVSTI F IMPER[ATOR] VII. Head laureate r.

Rev. Illegible. 2 Æ. Struck A. D. 12-14.

2513-14. *Obv.* TI CAESAR AVGVST F IMPERAT V. Laureate head l.

Rev. ROM ET AVG in exergue. Altar between two columns, each surmounted by a Victory. The Victories are holding out wreaths in r.

Æ 3. Cohen 31.

Caligula.

2515-16. *Obv.* C CAESAR AVG GERMANICVS PON M TR POT. Head bare l.

Rev. VESTA S C. Vesta veiled, seated l., holding patera and sceptre.

Cohen 27. M. and S. 30. Æ 2.

Claudius I (A. D. 41-54)

Sestertii. Head, laureate, r.

Obv. (when legible and unless otherwise stated) TI CLAVDIVS CAESAR AVG P M TR P IMP.

*2517-24. *Rev.* EX S C OB CIVES SERVATOS in oak wreath. Cohen 39. M. and S., 60. On the civic crown see Pliny N. H. xvi. 4, 5, 13; Tac. A. iii. 21, 4; xii. 31, 7; xv. 12, 4; xvi. 4, 2.

*2525-6. *Rev.* NERO CLAVDIVS DRVSVS GERMAN IMP. In field S C. Triumphal arch surmounted by equestrian statue r. between two trophies.

Cohen 48. M and S. 62.

*2527-8. (= I 10).

Dupondius and Asses.

2529-32. (= I 12). 3*.

2533-53. (= I 14-21) 5*. Mostly barbarous.

*2554. (= I 22).

*2555. Illegible. Æ 2 (as).

Nero Claudius Drusus (died 9 B. C.)

*2556-9. *Obv.* NERO CLAVDIVS DRVSVS GERMANICVS IMP.
Head bare l.

Rev. TI CLAVDIVS CAESAR AVG P M TR P IMP. In ex.
S C. Claudius seated l. on curule chair, holding
branch: around him, shields, spears, &c.

Cohen 8. M. and S., Claudius 78. Sestertii.

Antonia, mother of Claudius I

2560-61. (= I 22, but not as 22 local imitation). Dupondius. 1*.

Nero (A. D. 54-68)

Denarius

*2562. *Obv.* NERO CAESAR AVGVSTVS. Head laureate r.

Rev. CONCORDIA AVGVSTA. Concord seated l. holding
patera and cornucopiae.

Cohen 67. M. and S., 43. Denarius, A. D. 63-8.

Dupondii and Asses

2563. *Obv.* NERO CLAVD CAESAR AVG GER P M TR P IMP P P.
Head bare r.; beneath, a globe.

Rev. ARA PACIS SC. Altar ornamented with palmettes
and bas-reliefs of Rome seated.

Cohen 27.

2564. (As I 25-6, but perhaps the longer legend of Cohen 243).
Cp. Tacitus A. xiv, 14: *Vetus illi cupido erat curriculo-
quadrigarum insistere, nec minus foedum studium cithara
ludicrum in modum canere.*

2565-6. *Obv.* Head laureate r.

Rev. as I 28. Cp. Cohen 288 foll. 1*.

2567-8. (= I 28).

For the tribunitian power see Tac. A. iv. 30, 1 (its exercise
by Tiberius); xiv, 48, 3 (its anticipated exercise by Nero),
ut condemnatum [sc. Antistium] a senatu intercessione
tribunicia morti eximeret.

? *Galba* (A. D. 68-9)

2569. A denarius.

Vitellius (Rome, A. D. 69)

2570. *Obv.* A VITELLIVS GERM IMP AVG TR P. Head laureate r.

Rev. XV VIR SACR FAC. Tripod: above, a dolphin;
below, a raven.

Cohen 111. M. and S., 24, 3. Denarius.

Vespasian (A. D. 69–79)*Denarii*

2571. (= I 30). The *rev.* figure is Pax.
- *2572. *Obv.* DIVVS AVGVSTVS VESPASIANVS. Head laureate r.
Rev. ? Two capricorns supporting shield inscribed S C ;
 globe beneath.
 ? Cohen 497.
 Deum honor principi non ante habetur quam agere inter
 homines desierit. Tac. A. xv. 74, 4.

Sesterii

2573. *Obv.* IMP CAES VESPASIAN AVG P M TR P P P COS VIII.
 Head laureate r. Globe beneath.
Rev. SALVS AVGVSTA S C. Salus seated l. holding patera
 and sceptre.
 Cohen 436.
- 2574–5. Illegible. 1*.

Dupondii

Heads, radiate, r.

2576. *Obv.* IMP CAES VESP AVG P M T P COS. . . .
Rev. [FELICITAS PUBLICA S C.] Felicitas standing l.,
 holding [caduceus] and cornucopiae.
 ? Cp. Cohen 153 foll.
- *2577. *Obv.* IMP CAESAR VESPASIAN AVG COS IIII.
Rev. FORTVNAE REDVCI. In field S C. Fortune standing
 l., holding in r. hand rudder placed on globe, in l.
 cornucopiae.
 Cohen 195. A. D. 72–3.
- *2578–9. (= I 33)
- *2580. *Obv.* IMP CAES VESPASIANVS AVG.
Rev. as I 37.
- *2581. Illegible.

Asses

Heads, laureate, r.

- *2582–3. *Obv.* IMP CAESAR VESPASIAN AVG COS III.
Rev. AEQVITAS AVGVSTI. In field S C. Aequitas stand-
 ing l., holding in r. hand balance, in l. sceptre.
 Var. not in Cohen, A. D. 71. 1*.
2584. Similar but obscure. Cp. Cohen 12 foll.
- 2585–6. (= I 36). 1*.

2587. *Obv.* IMP CAESAR VESPASIAN AVG COS III.
Rev. FORTVNAE REDVCI S C. Fortune standing l. holding
 rudder set on globe and a cornucopiae.
 Cohen 179.
2588. *Obv.* IMP CAES VESP AVG CENS.
Rev. PONTIF MAXIM. Vespasian seated r. holding sceptre
 and branch.
 Cohen 386.
- 2588-90. *Obv.* IMP CAES VESPASIAN AVG COS III.
Rev. PROVIDENT S C. Altar. Cp. I 40.
 Cohen 396. 1*.
- 2591-4. (= I 38, Cohen 480 with COS III and one IMP CAESAR).
 2*.
- 2595-7. *Obv.* IMP CAES VESPASIAN AVG COS VIII P P.
Rev. Eagle with outspread wings facing on globe, head
 turned r.
 Cohen 482. One uncertain.
- 2598-9. Illegible.

*Titus**Denarius*

2600. *Obv.* IMP TITVS CAES VESPASIAN AVG P M.
Rev. IMP XXII COS XVI CENS P P P.
 An ancient forgery: the *obv.* of an aureus (Cohen 267) of
 Titus and the *rev.* of an aureus (Cohen 279) of Domitian.

Asses

Heads, laureate, r.

2601. *Obv.* T CAES IMP AVG F TR P COS VI CENSOR.
Rev. S C. Hope standing l. holding flower and raising
 robe.
 Cohen 217.
2602. *Obv.* [IMP T CAES VESPASIAN AVG COS III.]
Rev. [VICTORIA AVGVSTI] S C. Victory moving l. and
 holding wreath and palm.
 Cohen 378.
2603. *Obv.* T CAES IMP PON TR P COS II CENS. Laureate
 head l.
Rev. VICTORIA NAVALIS S C. Victory r., standing on
 prow terminating in a serpent, and holding wreath
 and palm.
 Cohen 389.
2604. Illegible.

126 REPORTS OF THE SOCIETY OF ANTIQUARIES

Domitian (A. D. 81-96)

Sestertii : heads, laureate, r.

2605. *Obv.* IMP CAES DOMIT AVG GERM COS XI CENS PER P P.
Rev. IOVI VICTORI S C. Jupiter seated l., holding a
Victory and a sceptre.

2606-7. Illegible.

Dupondii (heads, radiate, r.)

*2608. *Obv.* IMP CAES DOMIT AVG GERM COS XVII [CENS PER
P P].
Rev. Illegible. Female figure standing l., no attributes
visible.
A. D. 95-6.

*2609. Illegible.

Asses (heads, laureate, r.)

2610. (= I 45).

2611. (As I 45 but C O S XIII), Cohen 125. A. D. 87.

2612. ? As Cohen 301 foll. with IOVI CONSERVAT S C *rev.*

2613. (= I 47).

2614. *Obv.* IMP CAES DOMIT AVG GERM COS XII CENS PER
P P. Laureate bust r. with aegis.
Rev. S C Mars, in military dress, striding l. with Victory
and trophy.
Cohen 432.

2615. *Obv.* CAESAR AVG F DOMITIANVS COS [? V]. Bust,
laureate, draped.
Rev. S C Hope walking l., holding flower and raising robe.
Cp. Cohen 454.

*2616. *Obv.* IMP CAES DIVI VESP F DOM[ITIAN AVG P M.]
Rev. [TR P COS VIII] DES VIII [P P.]. In field S C.
Minerva standing r. with thunderbolt and shield.
Cohen 587. A. D. 82.

2617. *Obv.* IMP CAES DOMIT AVG GERM COS XII CENS PER
P P.
Rev. VIRTUTI AVGVSTI S C. Valour standing r., with
foot on helmet, holding spear and parazonium.
Cohen 647.

2618-22. Illegible.

Nerva (A. D. 96-8)*Denarius*

- *2623. *Obv.* [IMP] NERVA CAES AVG P M TR P II COS III P P.
Head, laureate, r.
Rev. LIBERTAS PVBLICA. Liberty standing l., holding
cap in r., sceptre in l.
Cohen 117. A. D. 97.

Asses : heads, laureate, r.

2624. *Obv.* IMP NERVA CAES AVG P M TR P COS II P P.
Rev. AEQVITAS AVGVST S C. Aequitas standing l.,
holding scales and cornucopiae.
Cohen 4.
2625. Similar, but COS III P P. Cohen 7.
- *2626. Cp. Cohen 4-7.

Trajan (A. D. 98-117)

Denarii : busts, laureate and draped, r.

2627. *Obv.* IMP TRAIANO AVG GER DAC P M TR P.
Rev. COS V P P S P Q R OPTIMO PRINC. Rome, in
military dress, standing l., holding Victory and
spear.
Cohen 68.
- *2628. Same legends. *Rev.* Pax standing l., holding caduceus in
r. hand and cornucopiae in l.
Cohen 81. A. D. 104-111.
2629. *Obv.* IMP CAES NERVA TRAIAN AVG GERM. Head,
laureate, r.
Rev. PONT MAX TR POT COS II. Vesta, veiled, seated l.,
holding patera and torch.
Cohen 288.
- Sestertii* : busts, laureate, r., with paludamentum or aegis.
2630. *Obv.* IMP CAES NER TRAIANO OPTIMO AVG GER DAC
PARTHICO P M TR P COS VI P P.
Rev. PROVIDENTIA AVGVSTI S P Q R S C. Providence
standing l., holding sceptre, leaning on column
and pointing with her right hand to a globe lying
on the ground.
Cohen 320.

128 REPORTS OF THE SOCIETY OF ANTIQUARIES

2631. *Obv.* IMP CAES NERVAE TRAIANO AVG GER DAC P M
TR P COS V P P.

Rev. S P Q R OPTIMO PRINCIPI S C. Dacia, in an attitude
of dejection, seated l. on shields; in front of him
a trophy, at the foot of which are two shields.

Cohen 531.

2632. Illegible.

Dupondii: heads, radiate, r.

2633. Probably Cohen 573 with legends as no. 2631 above, but
rev. type a trophy with shields at foot.

2634. Attribution uncertain.

Asses: busts, laureate, r.

2635. Legends as no. 2631 above. *Rev.* Trajan galloping r.,
holding spear, and below his horse a kneeling suppliant
enemy.

Cohen 505.

2636. Illegible.

Hadrian (A. D. 117-38)

Sestertii

2637. *Obv.* IMP CAESAR TRAIANVS HADRIANVS AVG P M TR
P COS III. Head r.

Rev. CONCORDIA EXERCITVVM S C. Concord standing
l., holding standard in each hand, that to l. sur-
mounted by an eagle on a thunderbolt, that to r.
by a crown.

Cohen 268.

*2638. *Obv.* [IMP] CAESAR TRAIAN HA[DRIANVS AVG.] Bust,
laureate, draped and cuirassed, r.

Rev. [P M TR P COS III]. In field, S C. Spes walking l.,
holding flower in r. hand and catching up dress
with l.

Cohen 1154. A. D. 121-2.

*2639. *Obv.* HADRIANVS AVG COS III P P. Head, laureate, r.

Rev. ?[SPES P R]. ?In field, S C. Spes as preceding.

?Cohen 1415. A. D. 134-8.

2640-2. Illegible.

Dupondius: head, radiate, r.

2643. *Obv.* IMP CAESAR TRAIAN HADRIANVS AVG P M TR P
COS III.

Rev. FELICITAS AVGVSTI SC. Felicitas standing l., holding caduceus and cornucopiae.

Cohen 641.

Asses

2644. *Obv.* HADRIANVS AVGVSTVS P P. Bust, laureate, draped, r.

Rev. Probably HILARITAS P R COS III SC, with Hilaritas standing l., giving palm to a boy on l. and holding cornucopiae: girl to r.

Cp. Cohen 820.

2645. *Obv.* HADRIANVS AVGVSTVS P P. Head, laureate, r.

Rev. SALVS AVGVSTI SC. Salus seated l., feeding serpent twined round an altar, left elbow resting on chair.

Cohen 1347.

2646-7. Illegible.

Sabina, wife of Hadrian (A.D. 128-36)

2648. *Obv.* SABINA AVGVSTA. Bust, diademed, r., with long plait at back.

Rev. CONCORDIA AVGVSTA. Concord seated l., holding patera and sceptre.

Cohen 24. Denarius.

Antoninus Pius (A.D. 138-61)

Denarii (heads, laureate, r.)

2649. *Obv.* ANTONINVS AVGVSTVS P P TR P XII.

Rev. COS IIII. Abundance standing l., holding two ears of corn and an anchor; to l. a modius filled with ears of corn.

Cohen 284.

Sestertii: heads, laureate, r.

*2650. *Obv.* ANTONINVS AVGVSTVS P P TR P XI.

Rev. ANNONA AVGVSTA. In field, S C. Annona standing l., holding in r. hand two ears of corn, in l. anchor. Modius at foot.

Cohen 39.

A.D. 148. Cp. nos. 2857, 3008. Annona may signify also the price of corn as well as the annual supply. In the severe winter of 400 B.C. the roads were blocked by snow and the Tiber frozen; but Livy (v, 13, 1) tells us that wheat prices remained steady—'Annona ex ante convecta copia nihil mutavit'. The ship's prow on the coin of

Claudius II (3008) denotes the oversea sources (Africa, Egypt, Sardinia, &c.) of the Roman supplies.

2651. (= I 82).

2652. *Obv.* ANTONINVS AVG PIVS P P TR P COS III.

Rev. GENIO SENATVS S C. The genius of the Senate standing l., holding branch and sceptre.

Cohen 400.

*2653. *Obv.* ANTONINVS AVG PIVS P P TR P.

Rev. LIBERALITAS AVG IIII. In ex., COS IIII. Antonine seated l. on platform. Behind him, the praetorian prefect standing ; before, Liberality standing with tessera and cornucopiae. Below platform, figure in toga standing r.

Cohen 498.

2654. *Obv.* ANTONINVS AVG PIVS P P TR P COS III.

Rev. OPI AVG S C. Ops seated l., holding sceptre and catching up the drapery on her shoulder with her l. hand.

Cohen 569, but no flower on bar of seat.

2655. *Obv.* Similar.

Rev. REX QVADIS DATVS S C. Antonine standing l., giving his hand to the king of the Quadi and holding a roll in l.

Cohen 687.

*2656. *Obv.* Similar, but COS II.

Rev. Illegible. Salus standing l., feeding serpent on altar.

Cp. Cohen 711, var. A.D. 139.

2657. *Obv.* ANTONINVS AVG PIVS P P IMP II.

Rev. TR POT XIX COS IIII S C. Concord standing l., holding a military ensign in each hand.

Cohen 988.

2658-61. Illegible. 1*.

Dupondii : heads, radiate, r.

*2662. Similar to 2652, but radiate. ?Cohen 404. A.D. 140-4.

*2663. *Obv.* Similar, but COS IIII.

Rev. PAX AVG. In field, S C. Pax standing l., setting fire to spoils with torch held in r. hand, in l. cornucopiae.

Cohen 593. A.D. 145-61.

*2664. Similar to 2656, but COS III, and radiate. Cp. Cohen 714.

Asses : heads, laureate, r.

2665. *Obv.* ANTONINVS AVG PIVS P P TR P XVIII.
Rev. BRITANNIA COS IIII S C. Britannia seated l. on
 a rock, putting r. hand to her mouth and resting
 l. on the rock ; in front of her a shield and a
 sceptre surmounted by an eagle.

Cohen 117.

2666. *Obv.* IMP T AEL CAES [HADR ANTONINVS AVG PIVS].
Rev. [P M TR POT] COS II S C. Fortune standing l.,
 holding rudder placed on globe, and a cornucopiae.
 Cp. Cohen 650.

Faustina senior (d. A. D. 141)

2667. *Obv.* DIVA FAVSTINA. Bust r., without veil.
Rev. AVGVSTA. Ceres standing r., holding sceptre and
 ear of corn.

Cohen 93-4. Denarius.

- *2668. *Obv.* DIVA FAVSTINA. Bust, draped, r.
Rev. AETERNITAS. In field, S C. Aeternitas standing l.,
 r. hand extended, l. holding sceptre.

Cohen 28. Sestertius.

2669. *Obv.* DIVA FAVSTINA. Bust r., without veil.
Rev. AVGVSTA, S C. Vesta standing l, holding patera
 and palladium, at her feet an altar.

Cohen 117. Sestertius.

Marcus Aurelius (A. D. 161-80.)

- *2670. *Obv.* M ANTONINVS AVG ARM PARTH MAX. Head,
 laureate, r.

Rev. TR P XX IMP IIII COS III. Victory standing facing,
 looking r., and fastening shield inscribed VIC PAR
 to palm.

Cohen 878. 166 A. D. Denarius.

Sestertii : heads, laureate, r.

2671. *Obv.* M. ANTONINVS AVG TR P XXV.
Rev. COS III S C. Mars striding r. with cloak flowing,
 carrying spear and trophy.

Cohen 127.

2672. *Obv.* M AVREL ANTONINVS AVG ARMENIACVS P M.
Rev. TR POT XIX IMP II COS III S C. Mars standing r.,
 holding spear and leaning on shield.

Cohen 796.

Dupondius : head, radiate, r.

2673. *Obv.* M ANTONINVS AVG TR P XXIIII.
Rev. SALVTI AVG COS III. S C in field. Salus standing
 l., feeding a serpent coiled round altar and holding
 sceptre in l. hand.
 Cohen 549.

Faustina Junior (A.D. 141-75)

2674. *Obv.* FAVSTINA AVGVSTA. Bust, draped, r.
Rev. VENVS. Venus standing r., holding sceptre and
 apple.
 Cohen 254. Denarius.

Sestertii

2675. *Obv.* FAVSTINA AVGVSTA. Bust r.
Rev. AVGVSTI PII FIL S C. Concord standing l., holding
 patera and cornucopiae.
 Cohen 22.
2676. *Obv.* FAVSTINA AVGVSTA. Bust r. ; hair waved with
 two rows of pearls.
Rev. HILARITAS S C. Hilaritas standing l., holding long
 palm and cornucopiae.
 Cohen 112.
- *2677. *Obv.* ?[FAVST]IN[A AVGVSTA]. Bust, draped, r.
Rev. ?[IVNONI]LV[CINAE]. ?Cohen 133.

2 Æ

- *2678. *Obv.* FAVSTINA AVG PII AVG FIL. Bust, draped, r.
Rev. Illegible. A.D. 141-61.
- *2679. *Obv.* FAVSTINA [AVGVSTA].
Rev. [FECV]ND AVGVSTAE. In field, S C. Empress as
 Fecunditas standing l. with child on each arm.
 On either side, at foot, a child standing.
 Cohen 97.
- 2680-82. Unclassified.

Annia Lucilla : (A.D. 147-83) wife of Lucius Verus

2683. Denarius. Bust, draped, r. Obscure.
2684. *Obv.* LVCILLA AVGVSTA. Bust, draped, r.
Rev. PIETAS S C. Pietas veiled standing l. at a lighted
 altar, raising r. hand and holding box of perfumes.
 Cohen 53. Sestertius.

2685. *Obv.* Similar.
Rev. VENVS S C. Venus standing l. holding apple and
 sceptre.
 Cohen 74. Sestertius.

Commodus (A.D. 180-92)

- *2686. *Obv.* M COMM ANT P FEL AVG BRIT. Head, laureate, r.
Rev. P M TR P XII IMP VIII COS V P P. In exergue, FOR
 RED. Fortune seated l., holding rudder with r.
 hand, and cornucopiae in l. Wheel beneath chair.
 Cohen 152. A.D. 187. Denarius.
- *2687. *Obv.* M COMMODVS ANT [P FELIX] AVG BRIT. Head,
 laureate, r.
Rev. [P M TR P XI IMP VII COS] V P P. In field, S C.
 Janus standing facing in domed two-columned
 temple.
 Cohen 489. A.D. 186. Sestertius.
2688. *Obv.* M COMM ANT P FELIX AVG BRIT. Head, radiate, r.
Rev. LIBERAL AVG VI P M TR P XI IMP VII COS V P P
 S C. Liberality standing l., holding a tessera and
 a cornucopiae.
2689. Illegible brass. As.

Bruttia Crispina (Augusta A.D. 177, put to death 183),
 wife of Commodus

- *2690. *Obv.* CRISPINA AVGVSTA. Bust, draped, r.
Rev. LAETITIA. In field, S C. Laetitia standing l.,
 holding wreath in r. hand, and in l. rudder placed
 on globe.
 Cohen 27. Sestertius.
2691. Early imperial denarius.
2692. Post-Neronian denarius.
- 2693-706. Unassigned first and second century brass, one a
 sestertius.
 2 Æ (13), 3 Æ (1). 3*.

Septimius Severus (A.D. 193-211)

Denarii: heads, laureate, r.

- *2707. *Obv.* Illegible.
Rev. Fortune standing l.

134 REPORTS OF THE SOCIETY OF ANTIQUARIES

2708. *Obv.* SEVERVS [AVG] PART MAX. Laureate, bust, r.
Rev. PART MAX PONT TR P IIII. Trophy: two captives
 seated r. and l. at foot.
 Hybrid. Ancient forgery. *Rev.* of Caracalla, Cohen 175 ;
 cp. Severus, Cohen 374.
2709. *Obv.* [L SEPT SEV PERT AVG IMP IIII].
Rev. [P M TR] P II [COS II P P]. Minerva standing l.
 with shield and transverse spear.
 Cohen 381.
2710. *Obv.* SEVERVS PIVS AVG.
Rev. RESTITVTOR VRBIS. Rome seated l., holding
 palladium and sceptre; behind her a shield.
 Cohen 606.

Julia Domna, wife of Septimius Severus (A.D. 193-217)

Denarii: busts r.

2711. *Obv.* IVLIA AVGVSTA.
Rev. IVNO REGINA. Juno, veiled, standing l., holding
 patera and sceptre: at her feet a peacock.
 Cohen 97.
 Cp. the prayer of Camillus before the assault and capture
 of Veii, 396 B.C.: 'Te simul, Juno regina, quae nunc
 Veios colis, precor, ut nos victores in nostram tuamque
 mox futuram urbem sequare, ubi te dignum amplitudine
 tua templum [on the Aventine] accipiat.' Livy v, 21, 3.
 See also no. 2860: as *conservatrix* (no. 2859) Juno has the
 same attributes, but is unveiled.
2712. *Obv.* IVLIA AVGVSTA.
Rev. VESTAE SANCTAE. Vesta standing l., holding
 patera and sceptre.
 Cohen 246.
- Caracalla* (Caesar A.D. 196, Joint Emperor 198,
 Sole Emperor 212-17)
- Denarii*: busts, laureate, draped, r.
2713. *Obv.* ANTONINVS PIVS AVG.
Rev. PART MAX P M TR P IIII. Trophy between two
 captives seated dejectedly l. and r.
 As Cohen 273, but earlier tribuniciate.

- *2714. *Obv.* ANTONINVS AVGVSTVS.
Rev. PONTIF TR P III. Caracalla standing l. with globe
 in r. hand and reversed spear in l.
 Cohen 413. A.D. 200.

Fulvia Plautilla (died A.D. 212 : wife of Caracalla)

- *2715. *Obv.* Illegible. Bust, draped, r.
Rev. CONC[ORDIAE AE]TERNAE. Caracalla and Plautilla
 clasping hands.
 Cohen 10. A.D. 202-5. Core of base denarius.

Julia Maesa (died A.D. 223)

- *2716. *Obv.* IVLIA MAESA AVG. Bust, diademed and draped, r.
Rev. PVDICITIA. Pudicitia seated l., raising r. hand and
 holding sceptre in l.
 Cohen 36. A.D. 218-23. Denarius.

Severus Alexander (A.D. 222-35)

Denarii

2717. *Obv.* IMP ALEXANDER PIVS AVG. Bust, laureate, draped
 and cuirassed, r.
Rev. IOVI PROPVGNATORI. Jupiter walking l. with
 flowing mantle and looking back, holding a
 thunderbolt.
 Cohen 76.
2718. *Obv.* IMP C M AVR SEV ALEXAND AVG. Bust, laureate
 and draped, r.
Rev. IOVI VLTORI. Jupiter seated l., holding Victory
 and sceptre.
 Cohen 95.
2719. *Obv.* IMP SEV ALEXAND AVG. Head, laureate, r.
Rev. VICTORIA AVGVSTI. Victory standing r., with foot
 on a helmet, writing VOT X on a shield fastened
 to a palm tree.
 Cohen 566.

Julia Mamaea : mother of Alexander.

(Augusta A.D. 222 : murdered A.D. 235)

- *2720. *Obv.* IVLIA MAMAEA AVG. Bust, diademed and draped, r.
Rev. VESTA. Vesta standing l. with palladium and up-
 right sceptre.
 Cohen 81. Denarius.

Gordian III (A. D. 238-44)

Antoniniani : busts radiate r.

2721. *Obv.* IMP GORDIANVS PIVS FEL AVG.

Rev. P M TR P V COS II P P. Gordian in military dress standing r., holding globe in l. hand and transverse sceptre in r.

Cohen 266.

2722. *Obv.* Similar.

Rev. VIRTVTI AVGVSTI. Hercules standing r., resting the back of his right hand on his hip, and leaning on his club, which is propped on a rock.

Cohen 404.

Philip I (A. D. 244-9)

*2723. *Obv.* . . . M AVG. Bust, radiate and draped, r.

Rev. Illegible.

Antoninianus. Billon.

Trebonianus Gallus (A. D. 251-3)

2724. (= I 97).

Cohen 6.

Volusian : son of Gallus (A. D. 251-3)

2725. *Obv.* IMP CAE C VIB VOLVSIANO AVG. Bust, radiate, r.

Rev. CONCORDIA AVGG S C. Concord standing l., holding patera and double cornucopiae.

Cohen 23. Æ 2.

Valerian Sen. (A. D. 253-? 9)

Antoniniani : busts, radiate, r. Billon.

2726. *Obv.* [IMP C P LIC VALE]RIANVS AVG.

Rev. [AEQVITAS] AVGG. ? Aequitas standing l., holding scales and cornucopiae.

Cp. Cohen 3.

2727. *Obv.* IMP C P LIC VALERIANVS P F AVG.

Rev. VICTORIAE AVGG IT GERM. Victory standing l., holding wreath and palm ; at her feet a captive.

Cohen 242.

Gallienus (A. D. 253-68)

Obv. unless otherwise stated, GALLIENVS AVG. Head, radiate, r. The references to the first Report do not include the mint marks, letters, and symbols in field, which are separately recorded when legible. On third-century mint marks see Webb, *Num. Chron.* 1921, esp. pp. 229 ff.

- 2728-9. (= I 98-9).
2730. Similar, but bust, radiate and draped, r.
Cohen 6.
2731. *Rev.* AEQVITAS AVG. Aequitas standing l., holding scales and cornucopiae. $\overline{|\epsilon}$.
Cohen 24.
- 2732-5. *Rev.* AETERNITAS AVG. Sol standing l.; r. hand raised, globe in l. Two $\overline{\tau|}$, one $\overline{\Gamma|}$.
Cohen 38. 2*.
- 2736-7. (= I 101). One \overline{zC} .
- 2738-9. *Rev.* APOLLINI CONS AVG. Centaur walking l. and holding globe and arrows. \overline{H} , \overline{M} .
Cohen 73.
- *2740. *Rev.* Same. Griffin walking l.
Cohen 76.
2741. *Rev.* APOLLO CONSER. Apollo standing l., holding branch of laurel and carrying cloak on l. arm.
Cohen 89.
- 2742-3. *Rev.* DIANA CONS AVG. Hart walking r. and looking l.
Cohen 154.
- 2744-6. Similar, but IMP GALLIENVS AVG. One $\overline{\bar{\epsilon}}$.
Cohen 153.
- 2747-9. As 2742-3, but stag walking l. One $\overline{\bar{x}}$.
Cohen 158.
- 2750-1. (= I 103-4) $\overline{\bar{F}}$, $\overline{\bar{XII}}$.
For other *di conservatores* of Gallienus besides Apollo and Diana, see I 107 and below 2760-4 (Jupiter), I 114 (Liber), below 2789 (Mercury), below 2790-4 (Neptune), below 2816-17 (Sol); and of Salonina see below 2859 and 2861 (Juno). Four of these occur in Livy's account of the first lectisternium ever held in Rome, prompted by the pestilence in the summer of 399 B.C. *Duumviri sacris faciundis* [cp. coin 2570 XV VIR SACR FAC], lectisternio tunc primum in urbe Romana facta, per dies octo *Apollinem* Latonamque, *Dianam* et *Herculem*, *Mercurium* atque *Neptunum* tribus . . . stratis lectis placavere (Liv. v, 13, 6).
Hercules is supplied by Cohen, Gallienus 316-18, and we may have to add Aesculapius (C. 140), Mars (C. 608), but they are not of the same coin series.

138 REPORTS OF THE SOCIETY OF ANTIQUARIES

2752. *Obv.* Bust, radiate, cuirassed, r.
Rev. FIDES MILITVM. Fides l., holding two standards.
 Cohen 238.
- 2753-4. (= I 105).
- 2755-7. (= I 106). One |s. 2*.
- 2758-9. *Rev.* ?Genius standing l.
 Cp. Cohen 294 foll.
- 2760-1. *Obv.* Bust, radiate and cuirassed, r.
Rev. IOVI [CONS AVG]. ?Goat walking r.
 ?Cohen 341.
2762. *Obv.* [IMP C P LIC GALLIEN]VS AVG. Bust similar.
Rev. IOVI CONSERVA. Jupiter standing l. with cloak on
 l. shoulder, holding thunderbolt and sceptre.
 Cohen 351.
- 2763-4. (= I 107) $\frac{p}{p}$ Milan, H| . 1*.
- 2765-6. (= I 108-10). One XI in field.
2767. *Obv.* Bust, radiate and cuirassed, r.
Rev. IOVI STATOR. Jupiter standing to front but looking
 r., holding sceptre and thunderbolt.
 Cohen 389.
2768. Apparently IOVI VICTORI as Cohen 397-400, but no
 cippus.
- 2769-72. As I 111, but *Obv.* with head, radiate, r., as Cohen 402.
 One varied ? Jupiter with cloak in l. hand. Two
 S| , one *•S| .
- 2773-4. (= I 112), but one barbarous rev. inscr. . . TITTA in
 large letters.
2775. *Obv.* Legend obscure. Bust.
Rev. LAE[TITIA AVGG]. ?Joy standing l. [holding
 wreath and anchor].
 Cp. Cohen 438 foll.
- 2776-7. *Obv.* [Bust, radiate, l. with spear and shield.]
Rev. [LEG II PART V P/F]. Centaur running l. and
 holding globe.
 Cp. Cohen 478 foll.
2778. *Obv.* [Bust, radiate and cuirassed, r.]
Rev. [LEG II PART VI P VI F]. Centaur running r. and
 holding club.
 Cohen 483.

2779. (= I 114). \bar{B} .
2780. (= I 115, but LIB[ERTAS] AVG as Cohen's type 596?)
 \underline{XI} .
2781. *Rev.* MARTI PACIF. Mars standing l., holding olive branch and leaning on shield; his spear rests on his l. arm.
 Cohen 609.
- 2782-4. *Obv.* Bust, radiate and cuirassed, r.
Rev. MARTI PACIFERO. Mars walking l., holding branch of olive in r. hand and shield with spear in l. One \underline{S} .
- Cohen 614.
- 2785-8. (= I 116-19). One \underline{A} , two \underline{H} .
2789. *Rev.* MERCVRIO CONS AVG. Marine monster r.
 Cohen 631.
- 2790-4. *Rev.* NEPTVNO CONS AVG. Hippocamp r., two \bar{N}
 Rome.
 Cohen 667. 1*.
- 2795-6. *Rev.* ORIENS AVG. Sol standing l., r. hand raised, whip in l. \bar{S} Rome.
 Cohen 685. 1*.
- *2797. *Rev.* PAX A[ETERNA]. Pax standing l. with olive branch in r. hand, transverse sceptre in l.
 Cohen 717.
- 2798-9. *Rev.* PAX AVG. Type similar.
 Cohen 727.
2800. *Rev.* PAX AVG. Pax walking l. and holding olive branch and sceptre.
 Cohen 741.
2801. *Obv.* [IMP GALLIENVS P AVG]. Bust, radiate, draped, and ? cuirassed, r.
Rev. [PAX AVGG]. As 2797.
 Cp. Cohen 750, but details obscure.
- *2802. *Rev.* PAX PVBLICA. Pax seated l. with olive branch in r. hand and transverse sceptre in l.
 Cohen 773.

140 REPORTS OF THE SOCIETY OF ANTIQUARIES

2803. *Obv.* IMP GALLIENVS AVG. Bust, radiate and draped, r.
Rev. PIETAS AVG. Pietas standing l. by a lighted altar,
 raising both hands.
 Cohen 783.
2804. *Obv.* IMP GALLIENVS AVG. Bust, radiate, r.
Rev. P M TR P VI COS. Rome seated l., holding Victory
 and spear : beside her a shield.
 Cohen 817.
2805. *Rev.* PROVI AVG. Providence standing l., pointing with
 staff to a globe at her feet and holding a cornucopiae.
 Cohen 854.
2806. (= I 120). Globe l. at Providentia's feet, as Cohen 869.
- *2807. *Rev.* PROVID . . . Providence standing l. P| Rome.
 Cp. preceding.
2808. *Rev.* ?SALVS AVG. ?Salus standing r., holding serpent
 in her arms and feeding it.
 Cp. Cohen 932.
2809. *Rev.* ?SALVS AVG. ?Salus standing l., feeding serpent
 which rises from an altar, and holding sceptre.
- 2810-15. *Rev.* SECVRIT PERPET. Securitas standing l., with
 legs crossed, holding a sceptre and leaning on a
 column. One a fragment or struck on small Æ 3
 Q flan.
 Cohen 961.
2816. *Obv.* Detail obscure.
Rev. SOLI CONS AVG. Pegasus r., rising.
 Cp. Cohen 979-80.
2817. *Rev.* Similar, but Pegasus l.
 Cohen 981.
- 2818-20. *Rev.* VBERITAS AVG. Fertility standing l. with purse
 in r. hand and cornucopiae in l. I* |ε Rome.
 Cohen 1008.
- 2821-2. *Rev.* VI]CT[ORIA AET]. Victory standing l. with
 wreath in r. hand and palm in l. One I| ,
 I* P| Rome.
 Cohen 1071.
2823. *Rev.* VICTORIA [AVG]. Same type. Z| .

2824. *Rev.* VIRTVS AVGVSTI. Mars standing l., setting foot on a helmet and holding branch and sceptre. X|.

Cohen 1322.

2825. Barbarous imitation with blundered legend . . . GALL•S AV, all r. of head.

Rev. Draped figure standing l. with cornucopiae. . . AVG.

2826-56. Illegible.

Cornelia Salonina (wife of Gallienus)

Antoniniani. *Obv.* (except one) SALONINA AVG. Bust, draped, diademed, r., and over crescent. Billon.

*2857. *Rev.* ANNONA AVG. Annona standing l., with two ears of corn and cornucopiae; modius at foot.

Cohen 15.

*2858. *Rev.* IVNO AVG. Juno seated l., with flower in r. hand and infant on l. arm.

Cohen 55.

2859. *Rev.* IVNO CONSERVAT. Juno standing l., holding patera and sceptre; at her feet a peacock.

Cohen 56.

2860. *Rev.* IVNO REGINA. Similar, but Juno veiled.

Cohen 67.

2861. *Obv.* COR SALONINA AVG.

Rev. IVNONI CONS AVG. Hart walking l. Δ .

Cohen 70.

2862-3. Unclassified.

Saloninus (Caesar A.D. 253; put to death by Postumus, 259)

2864. Illegible.

Valerian Junior (killed A.D. 257)

2865. *Obv.* DIVO VALERIANO CAES. Bust, radiate, draped, r.

Rev. CONSACRATIO. Eagle flying r. and carrying off Valerian to heaven. The Caesar holds a sceptre. Antoninianus. Billon. Cohen attributes to Saloninus (no. 5).

Postumus (A.D. 258-67)

Antoniniani: unless otherwise stated, *Obv.* IMP C POSTVMVS P F AVG. Bust, radiate, draped, r. Billon.

142 REPORTS OF THE SOCIETY OF ANTIQUARIES

2866. *Rev.* COS [IIII] or [V]. Victory standing r., holding wreath and palm.
Cohen 31-2.
2867. *Rev.* HERC PACIFERO. Hercules standing l., holding olive branch and a club with lion's skin.
Cohen 101. Cp. 2886-7.
2868. *Rev.* IMP X COS V. Victory standing r., holding wreath and palm.
Cohen 144.
- 2869-70. *Rev.* IOVI STATORI. Jupiter standing to front, looking r., holding sceptre and thunderbolt.
Cohen 159.
2871. *Rev.* LAETITIA AVG. Vessel with three or four oarsmen and helmsman moving l.
Cohen 167.
- 2872-3. (= I 127).
2874. Similar, but Sol to r. raising l. hand. Barbarous.
- *2875. *Rev.* PACATOR ORBIS. Head of Sol, radiate, r.
Cohen 214.
- 2876-7. *Rev.* PAX AVG. Peace standing l., holding olive branch in r. hand and transverse sceptre in l. P| , P|* .
Cohen 215. For the mint marks see Webb, *Num. Chron.*, 1921, p. 245.
2878. *Rev.* P M TR P COS II P P. Postumus helmeted and in military dress, standing l., holding globe and spear.
Cohen 243.
2879. *Rev.* P M TR P IIII COS III P P. Mars with flowing cloak striding r. and carrying a spear and a trophy.
Cohen 273.
2880. *Rev.* PROVIDENTIA AVG. Providence standing l., holding globe and transverse sceptre.
Cohen 295.
2881. *Rev.* SAE CVLI FELICITAS. Postumus in military dress standing r., holding transverse spear and globe.
Cohen 331.
2882. *Rev.* SALVS AVG. Aesculapius standing to front but looking l., leaning on a staff round which a serpent is coiled.
Cohen 336.

2883. *Rev.* VICTORIA AVG. Victory walking l., holding wreath and palm : at her feet a captive.

Cohen 377.

2884-5. *Rev.* VIRTUS AVG. Mars standing r., holding a spear and leaning on a shield. 1* uncertain.

Cohen 419.

2886-7. *Rev.* VIRTUS EQVITVM. Hercules standing r., resting the back of his hand on his hip, and leaning on a club which is wrapped in a lion's skin and propped on a rock.

Cohen 443.

2888. *Rev.* Illegible.

Sestertii

*2889. *Obv.* IMP C M CASS LAT POSTVMVS P F AVG. Bust, radiate, draped and cuirassed, r.

Rev. LAETITIA. In exergue AVG. Galley l.

Cp. Cohen 183.

2890. *Obv.* Similar. Bust, radiate, draped, r.

Rev. P M TR P COS III P P S C. Type as 2878.

Cohen 262.

Æ 2

2891. *Obv.* Similar.

Rev. As 2867.

Cohen 107.

Laelian (? A. D. 267-8)

*2892. *Obv.* IMP C LAELIANVS P F AVG. Bust, radiate and cuirassed, r.

Rev. VICTORIA AVG. Victory running r., with wreath and palm.

Cohen 4. Antoninianus.

Victorinus (? A. D. 268-70)

Antoniniani. *Obv.*, except where otherwise stated IMP C VICTORINVS P F AVG. Bust, radiate, draped, r. Billon.

2893. *Rev.* ABVNDANTIA AVG. Abundantia standing l., holding ? ears of corn, and cornucopiae.

2894. *Obv.* IMP C PI VICTORINVS AVG. Cuirassed.

Rev. AEQVITAS AVG. Equity standing l., holding scales and cornucopiae.

Obscure and uncertain. Cohen 8.

144 REPORTS OF THE SOCIETY OF ANTIQUARIES

- 2895-7. *Obv.* IMP C PIAV VICTORINVS P F AVG.
Rev. INVICTVS. Sun walking l., raising r. hand and holding whip in l.
 Cohen 46. Two *| . Two uncertain *obv.* readings.
- 2898-902. (= I 129-32). 2*. All *| .
- 2903-4. *Obv.* IMP VICTORINVS P F AVG.
Rev. [LAETITI]A AVG. Joy l., holding wreath and anchor : l. of field off flan.
 Cp. Cohen 57. One uncertain *obv.*
- 2905-7. *Obv.* IMP VICTORINVS P F AVG. Cuirassed.
Rev. ORIENS AVG. Sun radiate, striding l., raising r. hand and holding whip in l.
 Cohen 77.
- 2908-24. (= I 133-7). One each V|P, V| , V•| , two V|*. 4*.
2925. *Obv.* IMP C PIAV VICTORINVS P F AVG.
Rev. PAX AVG. Peace standing l., holding olive branch in r. and transverse sceptre in l.
 Cohen 83.
2926. *Obv.* Cuirassed.
Rev. Similar, but sceptre not transverse.
 Cohen 87.
2927. Barbarous 3 Æ Q imitation of preceding.
- 2928-30. *Obv.* Draped and cuirassed.
Rev. PIETAS AVG. Pietas standing l. by an altar, dropping on it a grain of incense and holding a box of perfumes.
 Cohen 90.
2931. *Obv.* IMP VICTORINVS P F AVG.
Rev. Similar, but patera in r. hand instead of dropping incense.
 Cohen 92.
- *2932. Similar, but the normal *obv.* legend.
 Cohen 93.
- 2933-40. (= I 138). Two uncertain in detail. 1*.
- 2941-9. *Rev.* SALVS AVG. Salus standing r., holding serpent in her arms and feeding it. One ? overstruck *obv.*
 Cohen 112.

2950-8. (= I 139). One uncertain. 2*.

2959-60. *Obv.* Cuirassed.

Rev. SPES PVBLICA. Hope moving l., holding flower in r. hand and catching up robe with l.

Cohen 120.

2961-2. *Rev.* VICTORIA AVG. Victory moving l., holding wreath and palm.

Cohen 126, but legends obscure.

2963-77. (= I 141-3). 2*.

2978-98. Illegible: one retaining silver wash.

Marius (A. D. 268)

2999. *Obv.* IMP C M AVR MARIVS AVG. Bust, radiate and cuirassed, r.

Rev. VICTORIA AVG. Victoria standing l., holding wreath and palm.

Antoninianus. Billon. Cohen 19.

3000. Similar, but Victory walking l.

Claudius II Gothicus (A. D. 268-70)

3001-6. *Obv.* IMP C CLAVDIVS AVG. Bust, radiate, r.

Rev. AEQVITAS AVG. Aequitas standing l. with balance and cornucopiae. One IS Rome.

Cohen 6. Three, details uncertain (Cohen 6 foll.). 2*.

3007. *Rev.* AETERNIT AVG; Sun standing l., raising r. hand and holding globe in l.

Cohen 16.

3008. *Obv.* IMP C CLAVDIVS AVG. Bust, radiate, r.

Rev. ANNONA AVG. Annona standing l., holding ears of corn and a cornucopiae, and setting r. foot on prow of vessel.

Cohen 21.

3009. Similar, but IMP CLAVDIVS AVG.

Cohen 22.

3010. *Obv.* IMP CLAVDIVS AVG. Head, radiate, r.

Rev. CERES AVG. Ceres standing l., holding ears of corn and cornucopiae. Modius to r.

Cohen 29.

3011-15. (= I 153-4). 1*.

146 REPORTS OF THE SOCIETY OF ANTIQUARIES

- 3016-18. *Obv.* IMP C CLAVDIVS AVG. Head or bust, radiate, r.
Rev. FIDES EXERCI. Fides standing r., holding two standards, one transverse.
 Cohen 84.
- 3019-20. (= I 155-6).
- 3021-23. *Obv.* IMP CLAVDIVS P F AVG. Bust, radiate, r.
Rev. FIDES MILIT. Fides standing l., holding two standards.
 Cohen 88. One \bar{C} .
- 3024-6. (= I 157). All ϵ .
3027. *Obv.* IMP CLAVDIVS CAESAR.
Rev. FORTVNA AVG. Fortune standing l. with rudder and cornucopiae.
 Cohen 97.
3028. *Obv.* IMP CLAVDIVS AVG. Head, radiate, r.
Rev. GENIVS AVG. Genius, with modius on head, standing l. at an altar, holding patera and cornucopiae.
 Cohen 109.
3029. Similar, but *rev.* GENIVS EXERCI.
3030. *Obv.* IMP C CLAVDIVS AVG.
Rev. Similar, but no altar.
 Cohen 114.
- 3031-2. Similar, but IMP CLAVDIVS AVG. I*. \underline{Z} Rome.
 Cohen 115.
- *3033. *Obv.* Bust, radiate and cuirassed, r.
Rev. [I]NVICTVS. Sol advancing l., r. hand raised, in l. whip.
 Not in Cohen.
- 3034-6. *Obv.* IMP C CLAVDIVS AVG. Bust, radiate, r.
Rev. IOVI STATORI. Jupiter standing r., holding sceptre and thunderbolt.
 Cohen 124. I*.
3037. Similar, but IOVI VICTORI.
 Cohen 125.
3038. Similar, but IMP CLAVDIVS AVG.
- 3039-42. (= I 158-60). One is Cohen 129 \underline{N} .
3043. Similar, with IMP CLAVDIVS AVG.
 Cohen 131.

- 3044-5. *Obv.* IMP CLAVDIVS AVG. Bust, radiate, r.
Rev. LAETITIA AVG. Joy standing l., holding wreath
 and cornucopiae.
 Cohen 138. XII, | P.
- 3046-7. Similar, but Joy holds wreath and anchor. Bust
 cuirassed.
 Cohen 140.
3048. *Obv.* IMP C CLAVDIVS AVG. Bust, radiate, r.
Rev. LIBERALITAS AVG. Liberty standing l., holding
 tessera and cornucopiae.
 Cohen 144.
- 3049-51. *Obv.* IMP CLAVDIVS AVG. Same bust.
Rev. LIBERTAS AVG. Liberty standing l., holding cap
 and sceptre.
 Cohen 150.
- 3052-4. (= I 161, with IMP CLAVDIVS AVG). Two | X.
 Cohen 151.
3055. Similar, but IMP C CLAVDIVS AVG.
 Cohen 152.
3056. (= I 162).
3057. Similar, but *rev.* MARS VLTOR.
 Cohen 160.
3058. *Obv.* Similar.
Rev. MARTI PACIF. Mars walking l., holding olive branch
 in r. hand, and spear and shield in l.
 Cohen 161.
3059. *Obv.* IMP CLAVDIVS P F AVG. Bust, radiate, r.
Rev. ORIENS AVG. Sun, radiate, standing l., raising r.
 hand, and holding globe in l.
 Cohen 185.
- 3060-3. *Obv.* IMP (one IMP C) CLAVDIVS AVG. Bust, radiate
 and draped, r.
Rev. PAX AVG. Peace standing l. with olive branch in r.
 hand and transverse sceptre in l. 2*.
 Cohen 197-8. One has the portrait characteristic of the
 Siscia mint.
- 3064-5. (= I 164).
3066. Similar, but *obv.* IMP CLAVDIVS P F AVG.
 Cohen 202.

3067. Similar, but barbarous and blundered legends :
Obv. VII AC.
Rev. S [or P]VΛX, and ? altar on l.
3068. (= I 163).
3069. *Obv.* IMP CLAVDIVS AVG. Head, radiate, r.
Rev. P M TR P II COS P P. Claudius walking r., holding
 transverse sceptre and globe. Δ| .
 Cohen 216.
- 3070-1. *Obv.* IMP CLAVDIVS P F AVG. Bust, radiate, r.
Rev. ?[PROVID AVG]. ? Providence standing l., holding
 globe and cornucopiae.
 ?Cohen 219. One barbarous.
- 3072-7. *Obv.* IMP CLAVDIVS AVG. Head, radiate, r.
Rev. PROVID AVG. Providence standing l., with legs
 crossed; pointing with a wand to a globe at
 feet, holding a cornucopiae in l. hand and leaning
 l. elbow on a column.
 Cohen 220.
3078. *Obv.* IMP C CLAVDIVS AVG. Bust, radiate, r.
Rev. PROVIDEN A AVG. Providence standing l., holding
 globe and transverse sceptre.
 As Cohen 225 with *rev.* legend var.
3079. *Rev.* ? Providence standing l., pointing with wand to globe
 at feet and holding sceptre.
 Cp. Cohen 226.
3080. *Rev.* PROVIDEN AVG, but Providence holds cornucopiae
 in place of sceptre.
 Cohen 227.
- *3081-2. *Obv.* IMP CLAVDIVS AVG. Head or bust, radiate, r.
Rev. PROVIDENT AVG. Providence of 3072-7.
 Cohen 233.
- 3083-4. (= I 165 with IMP C CLAVDIVS AVG).
3085. Similar, but *obv.* legend obscure.
 ?Cohen 262.
- 3086-7. (= I 166). One with IMP CLAVDIVS AVG has X.
 I*.
3088. ? *Rev.* SPES AVG. Hope standing l., holding flower in
 r. hand, catching up robe with l.
 ?Cohen 276.

- *3089-90. (= I 168).
 3091-2. *Obv.* IMP CLAVDIVS P F AVG. Head, radiate, r.
Rev. VICTORIA AVG. Victory standing l., holding wreath
 and palm.
 Cohen 292.
3093. Similar, but bust radiate and cuirassed.
- 3094-5. As 3091, but IMP C CLAVDIVS AVG.
 Cohen 293. 1*.
3096. Similar, but IMP CLAVDIVS AVG.
 Cohen 294.
- 3097-103. (= I 167 with IMP C CLAVDIVS AVG).
 Cohen 313. One ε. 1*.
3104. VIRTVS AVGVSTI type with Mars standing l., holding
 branch and spear.
 Cohen 323.
3105. ?Claudius II; *obv.* CLMM; *rev.* crude and apparently
 random lines.
3106. ?Claudius. *Rev.* Draped figure apparently standing r.,
 holding staff resting on small globe: l. hand
 extended. . . . T . . . only legible l. of type.
- 3107-26. Unclassified. One a minim (barbarous).

Posthumous coins of Claudius II

I have ventured to adhere to Cohen's arrangement of the eagle types before the altar series on the slender evidence of an altar coin overstruck on an eagle.

Obv. DIVO CLAVDIO. Head, radiate, r.

3127. *Rev.* CONSECRATIO. Eagle r., looking back. (= I 203).
 15-16 mm.
- 3128-73. *Rev.* Eagle standing l. or nearly facing, looking r.
 (= I 205-12). 9*. It is impossible to draw
 a dividing line between the distinctly left position
 (Cohen 43) and the nearly but never quite facing
 attitude (Cohen 46). Nor can the distinction of
 module between Cohen 43 or 46 and 44 be
 maintained. The Richborough coins range from
 13 mm. to 17 mm. 37 coins measured give
 13 mm. (2), 14-15 mm. (10), 15-16 mm. (12),

16-17 mm. (13). Several types are partly off the flan and the legends are thus often partly missing. The flans themselves are often more or less oval, with a difference of two or even three millimetres between the smallest and greatest diameters. The last observation applies also to the altar series.

3174. Similar, but *rev.* . . TAC I. of type.

Altar Types

3175. Similar, but *rev.* Altar overstruck apparently on eagle crosswise ; the perfectly clear legend, in letters of extraordinary irregularity in size, belongs to the altar type.

3176. *Obv.* IMP CLAVDIVS AVG.

Rev. Lighted altar with palmettes. Festoon on front.
15-16 mm.

3177-267. *Obv.* DIVO CLAVDIO. Lighted altar usually with palmettes, and the following variations on the front of the altar.

3177-8. Vertical divisions or ornaments. 18-20 mm.

3179-91. Festoon with dot above it, 12-18 mm. 3*.

3192. Similar, but strong featured barbarous bust on *obv.*
[Plate xxxvii, 1], and legend blundered.

Rev. . . . IO . X̄. 17 mm.

3193-233. Four panels with a dot in each. 12-21 mm.

3234. Similar. Minim, 9-10 mm., but the design developed into a grill pattern. Probably dots in the panels. [Plate xxxvii, 2.]

3235. Similar panels, but six short flames all along top of altar. 11-14 mm.

3236-7. Similar, but four or five large flames blowing r.

3238-67. Ornament not visible.

3268. Similar, but *rev.* CONSAECRATIO.

Cohen 39.

3269. *Obv.* Similar.

Rev. P M TR P II COS P P. Claudius standing l., holding branch and sceptre.

Cohen 217.

Quintillus (A.D. 270)

3270. *Obv.* IMP C M AVR CL QVINTILLVS AVG. Bust, radiate, draped, r.
Rev. LAETITIA AVG. Joy standing l., holding a wreath, and an anchor set on a globe.
 Antoninianus. Billon. Cohen 39.
3271. Unclassified.

Tetricus I (A.D. ? 270-3)

Antoniniani : base metal, busts, radiate, draped, r.

Obv. A. IMP C TETRICVS P F AVG.

B. IMP TETRICVS P F AVG.

- 3272-4. *Rev.* Draped figure standing l., holding cornucopiae. ? Abundantia or Aequitas. Obscure.
- 3275-83. (= I 219-21). 3*. Four A as Cohen 17, one B as Cohen 18.
- *3284. *Rev.* [? FELICIT AVG]. Female figure standing l., with patera and cornucopiae.
 ? Cohen 34.
- 3285-94. (= I 222-4). At least five barbarous, one with types partly off flan. Eight B as Cohen 37, one A as Cohen 42.
3295. Similar. *Rev.* . . . AGG.
- *3296-7. *Rev.* FIDES MILITVM. Barbarous, small flan.
- 3298-307. *Obv.* B.
Rev. HILARITAS AVG. Hilaritas standing l., with palm and cornucopiae. Three barbarous, of which two 3 Æ Q.
 Cohen 49 where fully legible.
- 3308-20. (= I 225-9). One barbarous with types partly off flan. 2*.
- *3321. Hilaritas type. Barbarous, small.
- 3322-5. (as I 230-5, but LAETITIA AVG). 1*.
- 3326-41. (= I 230-5). 3*.
- 3342-65. One of two preceding. 2*. Two barbarous 3 Æ Q.
 One minim.
3366. *Rev.* [LAETITI]A AVG N. Joy standing l., perhaps emptying cornucopiae into vase beside her, as Cohen 73.
 But legend of Cohen 74.

152 REPORTS OF THE SOCIETY OF ANTIQUARIES

- 3367-77. [= I 236-41 with *obv.* B and LAETITIA AVG N].
Cohen 75.
3378. *Rev.* LAET AGNG.
3379. *Obv.* A.
Rev. [MARS V]ICT[OR]. Apparently Mars striding r.,
carrying spear and trophy.
? Cohen 80.
3380. *Obv.* . . . CVS P . .
Rev. M . . . Figure standing apparently with shield
resting on its rim to r.
3381. *Obv.* IC . . CIVØE, apparently a blundered PIV ES, to r.
of head instead of l.
Rev. Moneta standing l., holding scales and cornucopiae.
Very barbarous.
- 3382-4. *Obv.* A.
Rev. ORIENS AVG. Sun-god advancing l., raising r. hand
and holding whip in l. |* (I).
Cohen 86.
- 3385-479. (= I 242-8). At least twelve barbarous, three 3Æ Q.,
three with types half off flan. Mostly *obv.* A (Cohen
95), but three IMP TETRICVS . . . (Cohen 96, 98-
9), two IMP TETRICVS AVG (Cohen 98), one *obv.*
B. 9*.
3480. *Obv.* CPI in large letters l. of bust. *Rev.* . . X—C . .
3481. *Obv.* . . TETRICVS AG.
Rev. V only to r., similar.
3482. *Obv.* IMP C in very large letters l. of head.
Rev. ? Similar.
3483. ? Similar, but *obv.* C PES TERICVS (*sic*), for which cp.
Cohen 32.
- 3484-6. *Rev.* Pax with transverse sceptre.
Cp. Cohen 100.
3487. *Obv.* A.
Rev. Same.
Cohen 101.
3488. *Obv.* B.
Rev. SPEX AVGG. Pax type with branch and erect
sceptre. Perhaps overstruck.

3489. *Obv.* IMP TETR . . .
Rev. Pax type with straight sceptre. *| . Small 3 Æ Q.
 module.
- 3490-503. Similar. Barbarous, two small. One *rev.* PAXX AV.
 9*.
- *3504. *Rev.* Pax type with transverse sceptre. Barbarous.
3505. Types barbarous: *rev.* Pax type, but inscr. ?PIV from
obv. of model.
- 3506-12. *Rev.* Sacrificial instruments. ?Cohen 117 or 120, but
 one IMP TETRICVS. Two barbarous.
3513. Similar, but barbarous, and . . . TETRIC in large letters.
3514. *Obv.* B.
Rev. PRINC IVVENT. Tetricus standing l., holding wand
 and sceptre.
 Cohen 131.
3515. Similar, but Tetricus holding spear in l., and patera over
 ?altar in r.
- *3516. *Rev.* PRO[VID AVG]. Providentia standing l., with wand
 and cornucopiae.
 Cohen 133.
- 3517-20. (=I 250). But one ?IMP C TETRICVS AVG (Cohen
 148). One barbarous.
3521. *Obv.* SALVS AVG.
Rev. Figure l., holding wreath and palm.
 ?Cohen 151.
- 3522-36. (=I 251-2). *Obv.* B. Three barbarous, one with
obv. r. of head CASC. 1*.
3537. Similar. *Obv.* A.
 Cohen 154.
- 3538-9. *Obv.* A.
Rev. SALVS AVGG. Salus standing l., and holding wreath
 and anchor. At her feet an altar.
 Cohen 156.
- *3540-1. Salus type.
- 3542-52. *Obv.* A.
Rev. SPES AVG. Hope moving l., holding flower in r.
 hand, and catching up robe with l.
 Cohen 158-60. Four barbarous. 3*.

154 REPORTS OF THE SOCIETY OF ANTIQUARIES

3553. As 3542, but barbarous with *rev.* PES (*sic*) AVG.

3554. *Obv.* B.

Rev. SPES AVGG. Hope standing l., holding flower and palm.

Cohen 162.

3555-60. *Obv.* A.

Rev. SPES AVGG. Type as I. 257.

Cohen 163. Three barbarous, one *obv.* IIVIPT [= IMP T.

3561-72. (= I 258). Mostly *obv.* A. 1*.

3573. *Obv.* C PIV EXV TETRI. . . .

Rev. Apparently Spes type, but PVAX.

3574-7. Spes types barbarous and small.

3578-80. Owing to a renumbering these were not used.

3581-8. *Obv.* A.

Rev. VICTORIA AVG. Victoria advancing l., with wreath and palm.

Cohen 185. 2*.

*3589-90. Victoria type, small.

3591-2. *Obv.* IMP TETRICVS AVG.

Rev. VIRTVS AVG. Mars r., holding spear and leaning on shield.

Cohen 199.

3593. B. Similar, but Mars l.

Cp. Cohen 200.

3594-603. (= I. 261-4). 6*.

3604. *Obv.* IMP C . . . CVS P F AV in large sprawling letters.

Rev. Mars with r. hand on shield (to l.) and spear in l. (on r.).

[Plate xxxvii, 3.]

3605-6. Virtus type. One rev. . . . OI.

3607. *Obv.* Blundered legend.

Rev. T . . . l. of type. Standing figure with cross-topped staff to r. [Plate xxxvii, 4.]

3608-11. Standing types with various attributes. Barbarous.

3612. *Obv.* IIVI PC TETRICVS P F AV.

Rev. IT VGG. Apparently Aequitas type.

3613. Very small, betw. 3 Æ Q and minim size. Only top of head visible and LRICIVS.

3614. *Obv.* MI of 'Imp' and T of 'Tetricus'.
Rev. Figure r., ?rudder in l., upper arms held horizontally. [Plate xxxvii, 5.]
3615. *Rev.* Figure walking r. with legs bare and slightly bent knees, upper arms horizontal, l. hand holding or dragging something. 14 mm. [Plate xxxvii, 6.]
3616. Smaller and cruder, and l. of types off flan. Probably Spes type.
3617. Period of Tetricus. *Rev.* Figure marching l., and holding a levelled trident. [Plate xxxvii, 7.]
3618. *Rev.* Slender figure facing; l. arm raised; r. arm with upper arm extended horizontally, forearm bent down and ?holding scales of which only the bar is visible. [Plate xxxvii, 8.]
3619. *Obv.* ICV[S].. r. of barbarous radiate head.
Rev. ... VIV. Standing figure facing with erect spear in l. [Plate xxxvii, 9.]
3620. *Rev.* T. to r. of ?Spes type.
- 3621-745. Illegible. Many barbarous. 27* (among which TITRICVS occurs twice and A, AV, AVVV for AVG).

Victorinus or Tetricus I

- 3746-52. Including * one Providentia type and * two Victoria types.

Tetricus II

Obv., unless otherwise stated, C PIV ESV TETRICVS CAES.
 Youthful bust, radiate, and draped, r.

3753. *Obv.* ... TET S .
Rev. Type of AEQVITAS AVG with Equity standing l., holding scales and cornucopiae.
 Cp. Cohen 1, but 3 Æ Q.
- 3754-7. *Rev.* COMES AVG. Victory standing l., with wreath and palm.
 Cohen 5.
- 3758-9. *Rev.* HILARITAS AVGG. Hilaritas standing l., holding palm and cornucopiae.
 Cohen 17. 1*.

156 REPORTS OF THE SOCIETY OF ANTIQUARIES

3760. *Rev.* LAETITIA AVG. Joy standing l., holding wreath and anchor.
Cohen 21.
3761. *Rev.* LAETITIA AVGG. Similar.
Cohen 22.
3762. *Rev.* LAETITIA AVG [?N]. Similar.
Cohen 24.
3763. *Rev.* [?PAX AVG]. Peace standing l., but details missing.
?Cohen 33.
- 3764-70. *Rev.* PAX AVG. Peace standing l. with olive branch and sceptre.
Cohen 34.
3771. Similar, but ?*obv.* CPESV
3772. *Obv.* . . . TETRICVS CAES.
Rev. as preceding, but *, and sceptre transverse.
3773. As 3771, but 3 Æ Q. blundered.
3774. *Rev.* Type as 3764.
- 3775-84. (= I 296-7). One barbarous 3 Æ Q. 2*.
3785. Similar, but apparently only vase (as C. 54) on *rev.*
- *3786-7. (= I 298).
3788. *Obv.* C P[E TETRICVS CAES].
Rev. Sacrificial instruments apparently as Cohen 55. Sprinkler, simpulum, ewer, sacrificial knife, and augural staff.
- 3789-90. *Rev.* Similar, but PIETAS AVGVSTOR.
3791. *Obv.* [CPIV]ESV TETRICVØ CAES. Similar.
3792. Similar, but *obv.* TETRICVØ in very large letters.
3793. *Obv.* C P E TETRICVS CAES.
Rev. Similar.
- *3794-6. *Rev.* PRINC IVVENT. Tetricus standing l., with wand and standard.
Cohen 64.
3797. ?Tetricus II.
Rev. Salus Aug. type with . . . VS A[VG]VS[TI].
3798. Uncertain Tetricus II; Salus Aug. type with . . . VS A[VG]VS[TI].

- 3799-833. (= I 299-303). 23 are Cohen 88. 2*. One twice struck after reversing flan, three barbarous 3 Æ Q., of which one has *rev.* P ∞ A.
- 3834-69. (= I 304). 19 are Cohen 97. 9*.
- 3870-4. (= I 305-7). Two 3 Æ Q.
3875. *Obv.* [? C P E] TETRICVS CAES.
Rev. VICTORIA AVG. Victory moving l., with wreath and palm.
 Cp. Cohen 103.
- 3876-7. Virtus type barbarous. 1*.
3878. *Obv.* . . . TIT . . . VC.
Rev. Soldier walking l., with sloped spear and small round buckler or bow held out before him. [Plate xxxvii, 10.]
3879. Unclassified.
Unassigned Coins of the Radiate series (mostly of the Gallic usurpers; all but one later than the debasement of the Antoninianus by Gallienus, and all earlier in type than the reform of Aurelian. A large number barbaric and many 3 Æ Q.).
- 3880-1. ? Aequitas type. Upper arms of Aequitas extended horizontally, forearms bent sharply down vertically to make pattern of scales. -□ on *rev.* of one. 3 Æ Q. [Plate xxxvii, 11].
- *3882. Felicitas type.
3883. ? Fortuna seated l. 3 Æ Q.
- *3884. Hilaritas type.
3885. ? Gordian III.
Rev. L Laetitia standing l., holding wreath and anchor.
 Cp. Cohen 121.
- *3886. Mars Victor type.
- 3887-8. Oriens Aug type. As Victorinus C. 77. 1*.
- 3889-910. Pax Aug type, mostly as Tetricus C. 95 foll. One CCA r. of head. 9*.
3911. *Obv.* ΘϞϫΥΙϚ,
Rev. Draped figure standing. ? branch or palm in r.

158 REPORTS OF THE SOCIETY OF ANTIQUARIES

- *3912-3. Princ. Juvent. type.
- *3914-15. Pietas Aug. type.
- *3916-18. Providentia type.
- 3919-23. Salus Aug. type. 3*.
3924. *Obv.* . . . VTVS AVG.
Rev. SALVS [AVG]. Salus standing l., holding rudder.
 Barbarous.
- 3925-6. Spes Aug. type. One 3 Æ Q.
- 3927-8. Spes Publica.
- *3929-32. Spes types.
3933. ? Ubertas type.
- *3934-7. Victoria type.
- *3938-44. Virtus type.
3945. *Obv.* . . . PAIC—AI, all r. of bust.
3946. *Obv.* Radiate bust, r. + behind bust.
Rev. Figure stands facing with ? spear in r.
3947. *Rev.* -VI-IO in large letters l. of type. Barbarous.
3948. *Obv.* HVCEL. Radiate bust, r. [Plate xxxvii, 12.]
Rev. LOC. Figure standing l., and ? holding two standards.
3949. *Obv.* Radiate head, r.
Rev. Two small Victories moving l. as if ascending a stairway, the l. hand figure being at a higher level than the r. 3 Æ Q. [Plate xxxvii, 13.]
3950. One 3 Æ Q. inscr. SI in large letters.
3951. *Rev.* Crude male figure in short dress apparently moving r. with ? spear in l. 3 Æ Q.
3952. Eagle l. with wreath in beak. 10 mm. [Plate xxxvii, 14.]
3953. *Obv.* AÆVJ r. of radiate bust.
Rev. Figure in short dress facing, with globe in l., and extended r. arm ending in a triangle of three dots or globes. 12 mm. [Plate xxxvii, 15.]
3954. *Obv.* P F AV[C] in large letters r. of head. 10 mm.
 Apparently a broken coin clipped to minim size.
3955. *Obv.* . . . P (or A)YM . . .
Rev. ? Victory r. . . Ç—∞ . . . Oval, 12-14 mm.

3956. *Obv.* Radiate bust half off flan.
Rev. Draped figure standing. VPT in large letters to r.
 12-13 mm.
3957. *Obv.* Radiate head r. with very thin neck. [Plate xxxvii, 16.]
3958. *Obv.* OIICA[?R] counter-clockwise behind head.
3959. *Rev.* Draped figure standing, palm-branch in lower r. field.
 Oval, 11-13 mm.
3960. *Obv.* Draped bust r., apparently radiate; drapery indicated by two dotted lines. Long beard indicated by an oblique dotted line on chin and three dotted lines depending. Legend r. of head a series of strokes.
Rev. Uncertain type. Legend l. of type a broken series of strokes. 3 Æ Q. perhaps with some silver in it. [Plate xxxvii, 17.]
- 3961-4378. Unclassified. Very many barbarous and a number 3 Æ Q. 133*.
- 4379-81. Unclassified, with wafer flans.
4382. Wafer flan with radiate head r. in outline. Perhaps Claudius II with eagle reverse. 12-14 mm.
 [Plate xxxvii, 18.]
- 4383-95. Minims. One ? Pax type.

Aurelian (A. D. 270-5)

- Obv.* IMP AVRELIANVS AVG. Busts, radiate and cuirassed, r.
4396. *Rev.* CONCORD LEGI. Concord standing l., holding two standards. P̄.
 Cohen 22.
4397. *Rev.* IOVI CONSER. Aurelian in military dress standing r., holding sceptre, and receiving globe presented to him by Jupiter, who stands holding a sceptre and with his cloak hanging behind him.
 Cp. Cohen 105.
4398. *Obv.* IMP VS AVG.
Rev. VICTORIA AVG. Victory standing l., holding wreath and palm. Ā
 Near Cohen 248.

4399. *Obv.* IMP C M AVRE
Rev. Figure advancing r.

Severina (wife of Aurelian)

4400. *Obv.* SEVERINA AVG. Bust, diademed, r., on crescent.
Rev. PROVIDEN DEOR. Fides standing r., holding two standards in front of sun-god, who stands radiate, with cloak on l. shoulder, raising r. hand and holding globe in l.

Cohen 12.

Tacitus (A. D. 275-6)

Obverses: IMP C M CL TACITVS AVG (except 4406).
 Busts, radiate, draped, and cuirassed, r.

4401. *Rev.* CLEMENTIA TEMP. Mars? walking l., holding branch and leaning on shield. A spear rests on his l. arm.

Cohen 15. XXIZ.

4402. *Rev.* [? PROVID AVG. Providence standing l., holding globe and transverse sceptre].

? Cohen 90.

4403. Similar, but *rev.* PROVIDE blundered N AVG. Q̄. (= I 323, which is of the same mint).

4404. *Rev.* [? PROVIDENTIA AVG. Providence standing l., holding wand and cornucopiae. At feet a globe].

? Cohen 100.

4405. *Rev.* SPES AVG. Hope walking l., holding flower in r. hand and catching up her robe with l.

Cp. Cohen 134.

4406. *Obv.* IMP CL TACITVS AVG.

Rev. TEMPORVM FELICITAS. Felicitas standing l., holding caduceus and cornucopiae. A| .

Cohen 144.

Probus (A. D. 276-82)

Busts, with stated exceptions, radiate, cuirassed, r.

4407. *Obv.* IMP C M AVR PROBVS AVG.

Rev. CLEMENTIA TEMP. Securitas standing l. with legs crossed, holding a sceptre and leaning on a column.

Cohen 84.

4408. *Obv.* IMP C PROBVS P F AVG. Bust, radiate, draped, and cuirassed.
Rev. COMES AVG. Minerva standing l., holding an olive branch and leaning on a shield. Spear rests on l. arm. A| .
 Cohen 105.
4409. *Obv.* IMP C PROBVS P F AVG.
Rev. PIETAS AVG. Piety standing l. by lighted altar, holding patera and box of perfumes.
 Cp. Cohen 435.
4410. *Obv.* IMP C PROBVS AVG. Bust, radiate, l., wearing imperial mantle, and holding sceptre surmounted by an eagle.
Rev. SOLI INVICTO. Sun radiate in quadriga galloping l., holding globe and whip. R fulmen Γ.
 Cohen 653.
4411. *Obv.* IMP C PROBVS P F AVG.
Rev. TEMPORVM FELICITAS. Felicitas standing r., holding caduceus and cornucopiae.
 Cohen 728.
4412. *Rev.* VICTORIA AVG. Victory moving l., holding wreath and trophy.
 Cohen 739 foll.
- *4413. Unclassified.

Diocletian (A. D. 284-305)

4414. *Obv.* IMP DIOCLETIANVS AVG. Bust, laureate, cuirassed, r.
Rev. GENIO POPVLI ROMANI. Genius, with modius on head, standing l., holding patera and cornucopiae.
 B| -
 TR
 Cohen 87. Follis.
- *4415. *Obv.* IMP C DIOCLETIANVS AVG. Bust, radiate, draped, and cuirassed, r.
Rev. IOVI VICTORI. Jupiter standing l., holding Victory on globe in r. hand, in l. vertical sceptre. Eagle at his feet. 3 Æ. Cf. Cohen 308.
4416. *Obv.* IMP C DIOCLETIANVS P F AVG. Bust, radiate, draped, r.

162 REPORTS OF THE SOCIETY OF ANTIQUARIES

Rev. PAX AVGGG. Peace standing l., holding olive branch
and transverse sceptre. Small brass. $\frac{S|P}{MLXXI}$.

Cohen *obv.* of 379 with *rev.* of 377. Webb 1237.

4417. *Obv.* D N DIOCLETIANO P F S AVG. Bust, laureate, r.,
with imperial mantle, holding olive branch and
mappa or book.

Rev. QUIES AVGG. Quies standing l., holding a lowered
branch and a sceptre. PLN.

Cohen 428. Follis.

Maximian (Caesar A. D. 285, Augustus A. D. 286–305).

4418–21. *Obv.* D N MAXIMIANO P F S AVG. Bust, laureate
and cuirassed, r.

Rev. GENIO POP ROM. Genius, turreted, standing l., with
patera and cornucopiae. All PLN.

Cohen 142. Folles. 1*.

4422. *Obv.* IMP MAXIMIANVS P F AVG. Bust similar.

Rev. GENIO POPVLI ROMANI. Genius with modius on
head standing l., holding patera and cornucopiae.

$\frac{S|F}{PTR}$.

Cohen 162. Follis.

4423. *Obv.* DIVO MAXIMIANO SEN FORT IMP. Bust, laureate
and veiled, r.

Rev. MEMORIAE AETERNAE. Lion walking r. In field
above, a club. 3 Æ Q.

Cohen 400.

4424. *Obv.* IMP C M VAL MAXIMIANVS AVG. Bust, radiate and
cuirassed, r.

Rev. PAX AVGGG. Peace standing l., holding olive branch
and erect sceptre. $\frac{S|P}{C}$. Small brass.

*4425. *Obv.* IMP MAXIMIANVS P F AVG. Bust similar.

Rev. Similar, but transverse sceptre. $\frac{S|P}{MLXXI}$.

Struck by Carausius. 3 Æ (rather thick and very typical
of imitations of continental style).

4426-7. *Obv.* IMP C MAXIMIANVS P F AVG. Head laureate r.
Rev. SACRA MONET AVGG ET CAESS NOSTR. Moneta
 standing l., holding scales and cornucopiae. One
 PTR.

Cohen 503. Folles.

4428. Unclassified.

Carausius (A. D. 287-93)

Obverse legends. A. IMP C CARAVSIVS P F AVG.

B. IMP CARAVSIVS P F AVG.

C. IMP CARAVSIVS AVG.

D. IMP CARAVSIVS P AVG.

E. IMP C CARAVSIVS AVG.

Busts. a. Radiate, draped, r.

b. Radiate, draped, and cuirassed, r.

4429. *Obv.* B a.

Rev. ADVENTVS AVG. Carausius, in military dress, on
 horseback to l., raising l. hand and holding sceptre.
 Before the horse a prisoner seated, with hands
 tied behind back. ML— . V between horse's fore-
 legs.

Cohen 5, Webb 820.

No doubt referring to the entry of Carausius as emperor
 into London. The term 'adventus' in this sense
 goes back to republican times. So Livy v, 23, 4,
 of the victorious return of Camillus to Rome
 after the capture of Veii: 'Adventus quoque
 dictatoris, omnibus ordinibus obviam effusis,
 celebratior quam ullius unquam antea fuit.'

4430. *Obv.* B a.

Rev. [? AEQVITAS AVG. Aequitas standing l., holding
 scales and cornucopiae].

? Cohen 15.

*4431. *Obv.* D b.

Rev. APOLLINI CO AVG. Griffin standing l. MS[C?].
 Cp. Webb 239, obverse var.

4432. *Obv.* B a.

Rev. COMES AVG. Minerva standing l., holding olive
 branch and leaning on shield. A spear rests in
 crook of her l. arm.

Cohen 22, Webb 841.

4433. *Obv.* IMP C CARAVSIVS AVG.
Rev. COMES AVG. ? Neptune standing l., holding dolphin and reversed trident: r. foot planted on vessel, mantle on l. shoulder. Under his l. foot a dolphin.
Rev. obscure.
 Webb 835, ?Cohen 23.
- *4434. *Obv.* B b. COMES AVG. Victory standing l., holding wreath and palm.
 Cohen 25, Webb 836.
4435. *Obv.* B a.
Rev. CONCORDIA MILIT. Carausius standing r., giving his hand to Concordia standing.
 Cohen 37.
4436. *Obv.* IMP C M CARAVSIVS AVG. Bust a.
Rev. CONCORDIA MILITVM. Same type.
- 4436 a. *Obv.* IMP C CARA . . . Bust a.
Rev. ?[FELICIT TE]MP. Draped figure standing l., holding caduceus in r. hand and cornucopiae in l.
 Rouen type, but cp. Webb 32, 33.
4437. *Obv.* [E].
Rev. [FIDES MILIT]. ? Fides standing, holding two standards. MLXXI.
 Cp. Cohen 72.
4438. (= I 327).
4439. Similar, but standards very large and Fides only half length. Attribution not certain.
- *4440. *Obv.* B b.
Rev. FORTVNA . . . Fortune standing l. with ? rudder and cornucopiae. ML.
4441. *Obv.* B a.
Rev. FORTVNA AVG. Similar. Cp. Cohen 83. The G of AVG on *rev.* is clear.
 See Webb 38.
- 4441-2. *Obv.* A a.
Rev. Very worn. Similar. One $\frac{S}{C}$.
4443. *Obv.* B a.

Rev. HILARITAS AVG. Hilaritas standing l., holding long palm and cornucopiae. $\overline{\text{B|E}}$
 $\overline{\text{MLXXI}}$.

Cohen 102 ; Webb 46, mm var.

4444. *Obv.* E a.

Rev. LAETIT AVG. Laetitia standing l. with wreath and anchor. $\overline{\text{S|P}}$
 $\overline{\text{C}}$.

Webb 301.

4445-6. *Obv.* D a.

Rev. LAETITIA AVG. Similar. No mint mark.

Webb 919.

4447. Similar but obscure. $\overline{\text{ML}}$.

4448-9. D a.

Rev. LEG II AVG. Capricorn l. Both $\overline{\text{ML}}$.

Cohen 132, Webb 62.

4450. *Obv.* C or D a.

Rev. LEG II PARTH. Centaur pacing r. and holding uncertain object. $\overline{\text{ML}}$.

Cohen 134 or 135, cp. Webb 75-6.

4451. *Obv.* B a.

Rev. LEG II PARTH. Centaur pacing l., holding globe in r. hand and rudder over back. $\overline{\text{ML}}$.

Webb 70.

4452. *Obv.* [IMP] CARAVSIVS P F AVG. Radiate bust r.

Rev. LEG II PARTH. Boar to r. No mint mark.

Not in Cohen. Type of Webb 79-80.

4453. *Obv.* B a.

Rev. LEG VII CL. Bull r. $\overline{\text{ML}}$.

Webb 92.

4454. *Obv.* B a.

Rev. LEG VIII AVG. Bull standing r. $\overline{\text{ML}}$.

Cohen 145, Webb 99.

*4455. *Obv.* B a.

Rev. LEG [VIII IN]. Ram ststanding l. $\overline{\text{ML}}$.

Cp. Webb 102. Mr. Webb thinks this coin and those published by Stukeley must be imperfect specimens of the LEG I MIN legend (Webb 59 and 60).

166 REPORTS OF THE SOCIETY OF ANTIQUARIES

4456-62. *Obv.* B a.

Rev. MONETA AVG. Moneta standing l., holding scales and cornucopiae.

Cohen 174, Webb 958.

4463. *Obv.* First part of legend blundered. . . AVSIVS P I [or F] VN.

Rev. . . . AVG. Similar. Small irregular flan, 17 × 19 mm.

4464. *Obv.* A a.

Rev. Similar.

4465. *Obv.* VIRT[VS CARAVSI]. Bust l. with radiate and crested helmet.

Rev. MONETA AVG. Moneta l. with scales and cornucopiae. Cp. Webb 963.

PAX AVG types.

Rev. Peace standing l. with olive branch and vertical sceptre.

4466. (= I 336, but ? bust a). \bar{C} .

Cohen 192.

4467. (= I 337) \bar{A} .

4468-500. *Obv.* A-D a. One rev. ends . . . GP; one *obv.* . . . IVS P F N (probably a blundered AV) with rev.

. . . GP . . . AVG. \overline{ML} (4), $\frac{F|O}{ML}$ (1), $\frac{C|}{ML}$ (1),

\overline{MLXXI} (1), $\frac{|P}{-}$ (1). One ? double- or over-struck. Two barbarous.

Cohen 192 ff.

4501. Similar types. Early issue struck on Gallic flan, or perhaps a barbarous imitation of Cohen 192 foll. Mionnet's scale 4.

4502-51. (= I 337-343) B a. Three or four only with *obv.*

. . . AV as Cohen 193. Three \overline{ML} , two $\frac{F|O}{ML}$,

two $\frac{B|E}{MLXXI}$, one $\overline{-XXI}$, one each $\frac{F|O}{-}$, $\frac{X|}{-}$, $\frac{S|C}{-}$,

$\frac{SC|}{-}$, $\frac{S|P}{-}$, \bar{C} . 2*.

*4552. *Obv.* B. Bust, radiate and cuirassed, r. \overline{ML} .

Cp. Webb 130.

*4553-5. (= I 344). One $\frac{F|O}{ML}$, Webb 128.

*4556. *Obv.* A. Bust, radiate and cuirassed, r. $\frac{S|P}{ML}$.

Webb 140.

4557-72. (= I 345). Two $\frac{B|E}{MLXXI}$, two $\frac{S|P}{MLXXI}$, three $\frac{S|P}{ML}$,
one \bar{C} . 1*.

Cohen 194.

*4573. *Obv.* IMP C M CARAVSIVS AVG. Radiate and cuirassed.
Cp. Webb 991, 1001.

*4574. *Obv.* IMP C MA CAR . . . Bust a.
Rev. Overstruck and illegible.

4575. *Obv.* E. Radiate and cuirassed.
Cohen 200.

4576-7. (= I 351).
Cohen 204.

4578. *Obv.* . . . VSIVS legible to r. of head, followed by one
illegible letter only. Small quinarius module.
Perhaps overstruck on Tetricus I, whom the worn
head suggests.

*4579-81. *Obv.* illegible. One $\overline{ML[XXI]}$.

Rev. Peace with transverse sceptre.

4582-86. (= I 354-5). C a. One rev. I II II V C.
Cohen 208.

4587-92. (= I 354-9). B-D a. One \overline{ML} , one $\frac{B|E}{MLXXI}$, $\frac{S|P}{ML}$.

4593-600. (= I 357-9). B a. One \overline{ML} , three $\frac{F|O}{ML}$.

Cohen 209.

4601. Similar, but . . . P F AV. ? no mint mark.

*4602-3. *Obv.* A b. Both $\frac{S|P}{ML}$.

Webb 149.

4604-8. *Obv.* A a. $\frac{S|P}{MLXXI}$ (3), $\frac{|P}{none}$ (1).

Cohen 215.

4609. *Obv.* A. Bust, radiate and cuirassed. $\frac{S|P}{MLXXI}$.

*4610. *Obv.* A. Bust, radiate, with imperial mantle, l.
Cp. Webb 469, 574.

4611. *Obv.* IMP C CARAVS . . .
Cp. Cohen 212 ff.

Other PAX AVG reverses

4612. *Obv.* B a.
Rev. Peace standing l., holding an olive branch and ?leaning on a short staff, but the 'staff' may be a fall of drapery, and there is a transverse line which may be a spear or a flaw in the die.

4613. *Obv.* B a.
Rev. Peace standing l., holding a cornucopiae and leaning on wand ; ?*rev.* twice struck.
Cohen 220, Webb 1021.

4614-16. *Obv.* B a.
Rev. Peace standing l. with olive branch and cornucopiae.
Cohen 222, Webb 1011.

4617. *Obv.* D b.
Rev. ? Similar.
Cp. Webb 155.

4618. *Obv.* a. CARAVSIVS P F AVG.
Rev. Peace l. with olive branch and blundered transverse sceptre.

4619. *Obv.* a. IMP CARAVSIVS II.
Rev. PAX AVG. Peace with palm branch in r. hand and cornucopiae in l.

4620-4. Unclassified PAX AVG types.

Overstrikes

4625. *Obv.* IMP . . . VS . . . G of the overstrike, outside which IE . . . NVS of the original. Radiate draped bust of Carausius r.
Rev. 'Pax Aug.' type of overstrike, to r. of which CON[S] of original.
Struck on a 'Conservator' type of Gallienus.

4626. Apparently a PAX AVG type of Carausius overstruck on a FIDES MILITVM of Postumus. Fides and her two standards are distinctly traceable, but the legend is PAX AVG.
- PAX AVGGG : Peace with transverse sceptre.
4627. *Obv.* A a.
Rev. No sceptre visible. S|P. The *obv.* lettering is in very small characters.
- 4628-31. *Obv.* A a $\frac{S|P}{MLXXI}$ (3). $\frac{P}{I}$ (1).
Cohen 239.
- *4632. *Obv.* b. . . CARAVSIVS P F AVG.
Cp. Webb 171.
- *4633. *Obv.* A b.
Rev. S|P.
Webb 548.
- *4634. *Obv.* A. Bust, radiate and cuirassed.
Rev. $\frac{S|P}{MLXXI}$.
Webb 172.
4635. *Obv.* CA . . . Barbarous imitation. ? Pax type with erect sceptre. $\frac{O}{I}$.
3 Æ Q.
4636. *Obv.* [IMP C M] CARAVS[IVS P F AVG]. Bust a.
Rev. [PIETAS AVG]. Pietas standing l. at a lighted altar and holding cornucopiae.
? Cohen 247.
4637. *Obv.* IMP CAR.
Rev. PROVID AVG. Providentia standing l., pointing with a wand to a globe at her feet and holding a cornucopiae. $\frac{S|P}{I}$.
Cp. Cohen 252.
- *4638. Similar, but fragmentary.
- *4639. Similar, but IMP C CARAVSIVS . . .
Rev. Double struck or overstruck.

170 REPORTS OF THE SOCIETY OF ANTIQUARIES

4640. *Obv.* A. a-b.
Rev. Providentia holding globe and cornucopiae. $\frac{S|C}{}$.
 Cohen 262.
4641. *Obv.* A a.
Rev. PROVID AVGGG. Providentia standing l., holding
 globe and cornucopiae. $\frac{S|P}{C}$.
 Cohen 271, Webb 427 with *obv.* legend var.
4642. Fragment: probably Cohen 272, similar, but *rev.* PROVIDE
 AVG.
4643. *Obv.* ?B a.
Rev. ?RENOVAT ROMA. Wolf to r. suckling Romulus
 and Remus. ? $\overline{\text{P}\Sigma\text{P}}$.
 ?Cohen 292, Webb 673.
4644. *Obv.* B a.
Rev. REST[IT ?GALL] the lacuna restored from the
 British Museum specimen. Carausius on left in
 military dress, standing l., holding globe and sceptre
 and crowned by Victory (on r.), who stands l. with
 a palm in her hand.
- *4645. *Obv.* B b.
Rev. ROMAE AETERN. Rome, seated l., holding r. winged
 Victory, l. vertical sceptre: by her side a shield.
 Not in Webb. ? $\overline{\text{M}\text{S}\text{C}\text{C}}$.
 Webb 443 var.
- 4646-53. (= I 371-2). *Obv.* B a. One $\overline{\text{ML}}$.
 Cohen 310.
- *4654-6. Similar, but bust b. One $\frac{I|E}{\text{MLXXI}}$, one $\overline{\text{ML}}$.
 Cp. Webb 182.
- 4657-64. Similar to two preceding types.
4665. Similar, but IMP C AVSIVS AVG. ?double struck.
4666. *Obv.* B a.
Rev. Salus seated l. on throne, feeding serpent coiled
 round altar and resting l. arm on back of seat.
 $\overline{\text{CXXI}}$.
 Cohen 321.

4667. *Obv.* A a.

Rev. SALVS AVGGG. Salus standing r. and feeding a snake which she holds in her arms. $\begin{matrix} S|P \\ \dots \\ MLXXI \end{matrix}$

Cohen 325.

4668-9. *Obv.* B a.

Rev. SPES AVG. Victory standing l. with wreath and palm. One 20-24 mm.

Not in Cohen, Webb 1132.

4670. *Obv.* IMP CA PEAV.

Rev. TEMP[ORVM FELIC]. Felicitas standing l., holding caduceus and cornucopiae; r. of *rev.* off flan.

Cp. Cohen 348.

4671. *Obv.* C a.

Rev. TVTELA. Tutela standing l. by altar, holding patera and cornucopiae.

Cp. Cohen 353, Webb 759 Rouen.

4672. *Obv.* Illeg. Bust a.

Rev. TVTELA AVG. Similar.

Cp. Cohen 355, Webb 763 ff. Rouen.

4673. *Obv.* D a.

Rev. VICTORIA AVG. Victory advancing l., holding wreath and palm. No mint mark. New var. *obv.* legend.

4674. *Obv.* CARAVS . . V . . VG. Bust l. with shield on l. shoulder and spear over r., wearing radiate crested helmet.

Rev. VIC . . RI . . . Victory advancing r., holding up wreath in r. hand and carrying a long palm branch over left shoulder. $\begin{matrix} F|O \\ \dots \\ ML \end{matrix}$. 23-26 mm.

Not in Cohen or Webb.

4675. *Obv.* IMP CARAVSI[VS P F]AG. Bust, radiate and ? mailed, r.

Rev. VITORI V A VC. Draped figure standing l. with sceptre in l. hand and ? branch in r.

4676-7. *Obv.* B [a].

Rev. VIRTVS AVG. Soldier helmeted standing r., holding spear and leaning on shield.

Cohen 391, cp. Webb 1174.

4678-81. *Obv.* A, B, D, or E a.

Rev. Similar.

Cp. Cohen 391 foll.

4682. *Obv.* [? IMP] CARAVSIVS P F AVG. Bust a.

Rev. [? VIR]TVS AVG. Two figures facing one another, that on l. draped to ankles, with shield by her l. side and holding erect spear or sceptre in r. hand (to l. of figure). ?Minerva. She presents ?a Victory to the Emperor, who holds his spear erect in r. hand between the goddess and himself. \bar{X} .

Not in Cohen or Webb, cp. W 1222.

4683. *Obv.* B a.

Rev. VIRTVS . . . Lion pacing r. with lifted head. \bar{C} .

Not in Cohen.

4684. *Obv.* IMP C M CARAVSIVS P F AV. Bust a.

Rev. VIRTVTI AVG. Hercules standing r., strangling a lion. On the ground behind him a club. No mint mark.

Cp. Cohen 404, with varied *obv.* legend, and Webb 493.

4685. *Obv.* B a.

Rev. Figure standing r. with erect spear to l. and resting l. hand on shield (to r.); to r. of type AX . . In exergue \bar{D} .

4686. Overstrike. ?'Salus' type standing at altar with spear erect in l. hand; ?also a cornucopiae across the spear.

4687-740. Unclassified. One $\bar{M}\bar{L}$, one \bar{C} . One *rev.* or twice struck. Eight are attributed by flan only, five from along the east bank being apparently damaged by fire. 15*.

Allectus

Obverse Legends. A. IMP C ALLECTVS P F AVG.

B. IMP C ALLECTVS P AVG.

Busts. a. Radiate and draped, r.

b. Radiate and cuirassed, r.

c. Radiate, draped, and cuirassed, r.

4741-6. *Obv.* A b.

Rev. LAETITIA AVG. Laetitia standing l., holding wreath and anchor.

$\frac{S|A}{ML}$ (3), $\frac{S|A}{MSL}$ (1), $\frac{S|P}{CL}$ (1), $\frac{S|P}{C}$.

Cohen 15, Webb 26.

*4747. Similar, but LAETITI AVG. $\frac{S|A}{ML}$.

Webb 25.

4748-9. *Obv.* B b.

Rev. LAETITIA AVG. Vessel under sail with four rowers. \overline{QC} .

Cohen 20.

*4750-1 *Obv.* A b.

Rev. MONETA AVG. Moneta standing l. with scales and cornucopiae. One $\frac{S|A}{ML}$, one $\frac{S|P}{C}$.

Webb 31 and 132, Cohen 25.

*4752. *Obv.* A b.

Rev. ORIENS AVG. Sol, standing l., r. hand raised, l. holding globe. $\frac{S|P}{C}$.

Cp. Webb 34.

4753-6. (= I 387). $\frac{S|P}{ML}$, \overline{Q} , $\frac{S|P}{ML}$, $\frac{P}{ML}$ the first two 'quinarii'.

*4757. (= I 388). $\frac{S|P}{ML}$.

4758-9. (= I 387 or 388). \overline{ML} , \overline{QC} .

*4760. (= I 390).

4761-2. *Obv.* A c.

Rev. Peace standing l. with olive branch and transverse sceptre. $\frac{P}{ML}$, $\frac{S|P}{C}$.

Cohen 37.

4763-5. (= I 391-2). Two $\frac{S|A}{ML}$, one $\frac{S|P}{ML}$. 2*.

4766. *Obv.* IMP C ALLECTVS P F I AVG. Bust a.

Rev. PROVID AVG. Providence standing l., holding globe and cornucopiae. $\frac{S|P}{C}$.

Cohen 44.

174 REPORTS OF THE SOCIETY OF ANTIQUARIES

- *4767. *Obv.* Similar, but bust c.
Rev. PROVIDE AVG. Providence standing l., pointing with staff in r. to globe at her feet, and holding cornucopiae in l. $\frac{S|P}{C}$.
 Cp. Webb 153.
- 4768-70. *Obv.* A b. *Rev.* PROVIDENTIA AVG. Providence standing l. with globe and cornucopiae. One $\frac{S|A}{MSL}$, one $\frac{S|P}{C}$. Cp. Webb 58 and 159.
 Cohen 51. I*.
- *4771-2. *Obv.* A b. *Rev.* PROVIDENTIA AVG. Providence as in 4766. $\frac{ML}{C}$, $\frac{S|P}{C}$.
 Webb 168, 61. Cohen 54.
4773. Similar, but ? rudder instead of staff on globe.
- 4774-89. *Obv.* A a-b.
Rev. VIRTVS AVG. Sailing vessel. Five \overline{QL} , eight \overline{QC} .
 Cohen 81. I*.
4790. *Obv.* B b. Similar.
 Cohen 82.
4791. *Obv.* A b.
Rev. Similar but five or six rowers. \overline{QL} .
 Cp. Cohen 85.
- 4792-9. Unclassified. One each $\frac{S|A}{ML}$, \overline{ML} , $\frac{|F}{|}$.

Constantius I (Caesar A. D. 292 ; Augustus A. D. 305-6)

All *folles*.

- 4800-1. *Obv.* CONSTANTIVS NOB CAES. Head, laureate, r.
Rev. GENIO POPVLI ROMANI. Genius, wearing modius on head, standing l. and holding patera and cornucopiae. $\frac{B|\Gamma}{PL}$, $\frac{B|}{PL}$.
 Cohen 61.
4802. *Obv.* FL VAL CONSTANTIVS [N C]. Bust, laureate, r.
Rev. ? Similar.
 ? Cohen 81.

4803. *Obv.* FL VAL CONSTANTIVS NOB C. Head, laureate, r.
Rev. Similar.
Cohen 83.
4804. *Obv.* IMP CONSTANTIVS PIVS F AVG. Bust, laureate
and cuirassed, r.
Rev. Similar.
Cohen 97.
- *4805. *Obv.* CONSTANTIVS NOB C. Bust similar.
Rev. Similar, but genius turreted.
Cohen 104.
4806. *Obv.* DIVO CONSTANTIO PIO. Bust, laureate, veiled,
and cuirassed, r.
Rev. MEMORIA FELIX. Lighted altar festooned with
garlands; and eagle at each side of the base.
PLN.
Cohen 179.
- Helena* (wife of Constantius Chlorus, Augusta A.D. 306, died
A.D. 328)
- 4807-92. (= I 695-703). Fifteen TRP, six TRP•, one TRP✱,
three TRS, one •TRS, one TR—, one •TR—, one
TRC. II*.
Cohen 4.
- 4893-6. (= I 704-5). One $\frac{B|}{CONS}$, one PTR∩.
4897. Similar, but *Rev.* SECVRITAS REPVBLICE (*sic*). PTR.
Cohen 13.
- *4898. Types as I 695-703, but both reversed. Legends meaning-
less.
- *4899. Fragment apparently as preceding.
4900. Unclassified.
- Theodora* (second wife of Constantius Chlorus)
- 4901-11. (= I 707-14, but FL MAX THEODORA AVG.) Two
TRP, one each •TRP, TRP—, TR—, TRS.
Cohen 3.
- 4912-37. (= I 707-14). Two TRP, two TRP•, two •TRP•, one
TRP✱, two TRS, one TRS✱.
Cohen 4. 4*.

176 REPORTS OF THE SOCIETY OF ANTIQUARIES

- 4938-58. One of two preceding. One $\overline{\text{TRP}}$, one $\overline{\text{TRS}}$, one $\overline{\bullet\text{TRS}\bullet}$.
4959. *Obv.* Similar to I 707-14, but bust laureate and diademed.
Rev. Similar, but cross in field.
 Cohen 5.
- 4960-2. Unclassified : one 3 Æ Q uncertain.
4963. *Obv.* Bust l. ? laureate.
Rev. 'Pax Publica' type as Cohen 1, holding olive branch and transverse sceptre. Legend II II U. Barbarous minim uncertainly attributed.
4964. *Obv.* Bust, draped, r. ; hair waved in four horizontal rolls as in mid third-century fashion (cp. Otacilia).
 IIXIIODORAV.
Rev. Pietas type, PIET RO. [Plate xxxvii, 19].

Galerius (Caesar A. D. 292, Augustus A. D. 305-11)

Folles.

4965. As I. 552, but MAXIMIANVS NOB C.
 Cohen 54.
4966. Similar, but MAXIMIANVS NOB CAES.
 Cohen 57.
4967. *Obv.* ?IM ?NOB CAE.
Rev. GENIO POPY. S|. Attribution uncertain. Probably overstruck or double struck.

Maximin II Daza (Caesar A. D. 305, Emperor 308, died 313)

4968. *Obv.* IMP MAXIMINVS P AVG. Bust, laureate and cuirassed, r.
Rev. GENIO POP ROM. Genius wearing modius on head and holding patera and cornucopiae. $\frac{|*}{\text{PLN}}$.
 Cohen 61.

Maxentius (A. D. 306-12)

4969. *Obv.* IMP C MAXENTIVS P F AVG. Head, laureate, r.
Rev. CONSER[or ?GONSERV] VRB SVAE. Rome seated l. in columned temple. Details obscure. Follis.
 Cohen 21 (or 37 foll.).

Licinius Sen. (A.D. 307-23)

4970. *Obv.* Legend incomplete. Bust, laureate, cuirassed, r.
Rev. GENIO [AVGVSTI]. Genius with modius on head,
 standing l., holding head of Serapis in r. hand
 and cornucopiae in l. $\frac{T|}{RT}$.

Cp. Cohen 32 foll.

- 4971-4. *Obv.* IMP LICINIVS P F AVG. Bust, laureate, cuirassed, r.
Rev. GENIO POP ROM. Similar, but patera in r. hand.
 $\frac{S|F}{PLN}$, $\frac{|*}{PLN}$, $\frac{PLN}{PLN}$, $\frac{T|F}{PTR}$.

Cohen 49.

- 4975-7. *Obv.* Similar.
Rev. Similar to preceding, but Genius turreted.
 $\frac{T|F}{ATR}$, $\frac{T|F}{PTR}$ (2).

Cohen 53.

4978. *Obv.* IMP C VAL LICIN LICINIVS P F AVG. Bust,
 radiate, draped, and cuirassed, r.
Rev. IOVI CONSERVATORI. Jupiter standing l. with
 cloak on l. shoulder, holding Victory on a globe
 and a sceptre surmounted by an eagle. At his
 feet l. an eagle holding wreath in beak, and to r.
 a seated captive. 3 Æ.

Cohen 74.

$\frac{|X}{|II}$
 SMNB

4979. *Obv.* IMP LICINIVS P F AVG. Bust, laureate, draped,
 and cuirassed, r.
Rev. SOLI INVICTO COMITI. Sun-god, radiate, stands
 to front, looking l., raising r. hand and holding
 globe in l. $\frac{S|F}{MSL}$.

Cohen 163. 3 Æ.

4980. *Obv.* LICINIVS P AVG. Bust, helmeted and cuirassed, r.
Rev. VICT LAETAE PRINC PERP. Two Victories setting
 on a column a shield on which the left-hand
 Victory has written VOT P R. On the column S.

Cohen 171.

178 REPORTS OF THE SOCIETY OF ANTIQUARIES

Licinius Jun. (Caesar A.D. 317; murdered by Constantine I
A.D. 326)

4981. *Obv.* D N VAL LICIN LICINIVS NOB C. Bust, helmeted
and cuirassed, l., holding a spear and shield.
Rev. As Licinius I, 4978. *.
Cohen 21. 3 Æ.
4982. *Obv.* LICINIVS IVN NOB C. Bust, laureate and draped, r.
Rev. As Licinius I, 4980.
Cp. Cohen 55. 3 Æ.
4983. *Obv.* Similar, but bust radiate, draped.
Rev. VIRTVS EXERCIT. Trophy between two seated
captives, one in an attitude of dejection, the other
with hands bound behind back.
Cohen 60. 3 Æ.

Constantine I (Caesar A.D. 306, Augustus A.D. 307-37)

Obverse: Legends. A. CONSTANTINVS AVG.
B. CONSTANTINVS P F AVG.
C. CONSTANTINVS P AVG.
D. CONSTANTINVS MAX AVG.
E. IMP CONSTANTINVS AVG.

Busts. a. Laureate, draped, r.
b. Laureate, cuirassed, r.
c. Diademed and draped, r.
d. Laureate, draped, and cuirassed, r.

All coins 3 Æ unless otherwise stated.

4984. *Obv.* B b.
Rev. ADVENTVS AVG. Constantine on horseback to l.,
raising r. hand and holding spear in l. Behind
him a captive seated on the ground. PLN.
Cohen 3.
- 4985-92. (= I 556). STR (2), STR• (2), STR∪, STR• I*.
- *4993. *Obv.* A. Head, laureate, r.
Rev. Similar.
Cohen 15.
- 4994-5. (= I 557-8) STR•, STR•
- 4996-7. One of two preceding types.

- 4998-5002. *Obv.* A. Bust, laureate, r., with imperial mantle, and sceptre surmounted by eagle. $\overline{\text{PTR}}$ (2), $\overline{\text{PTR}} \cdot$ (1), $\overline{\text{STR}}$ (1).
Cohen 17. I*.
- 5003-4. Similar, but bust l.
Cohen 18.
5005. Similar, but bust, radiate, l. $\overline{\text{PLON}}$.
Cohen 19.
5006. Helmeted bust l.
Cohen 21.
5007. *Obv.* C b.
Rev. Similar. $\overline{\text{PLG}}$.
Cohen 23.
5008. *Obv.* A. Head, laureate, r.
Rev. CAESARVM NOSTRORVM. VOT X in laurel wreath.
 $\overline{\text{ESIS}}$ Ψ .
Cohen 34.
5009. *Obv.* B b.
Rev. COMITI AVGG NN. Sun-god, radiate, l., holding globe and whip. $\frac{|*}{\text{PLN}}$.
Cohen 48.
5010. *Obv.* A. Head, laureate, r.
Rev. CONSTANTINI AVG surrounding the inscr. VOTIS XX.
Cohen 82.
5011. Similar, but *obv.* IMP CONSTANTINVS P F AVG.
Cohen 85.
- 5012-13. *Obv.* A. Head, laureate, r.
Rev. D N CONSTANTINI MAX AVG. VOT XX in laurel wreath. $\overline{\text{P*AR}}$ (1).
Cohen 123.
- 5014-15. *Obv.* FL VAL CONSTANTINVS P F AVG. Head, laureate, r.
Rev. GENIO AVGVSTI. Genius standing l., holding patera and cornucopiae. Folles.
Cohen 174.

5016. *Obv.* FL VAL CONSTANTINVS NOB C. Bust b.
Rev. GENIO POP ROM. Similar, but Genius turreted.
 PLN.
 Cohen 196. Follis.
5017. *Obv.* E b.
Rev. Similar, but Genius wears modius instead of turreted
 crown. MSL.
 Cohen 208.
Reverse. GLORIA EXERCITVS. *Two soldiers facing,
 each holding a spear and resting on a shield:
 between them one standard.*
- 5018-19. *Obv.* A c. TRS[✠], TR—.
 Cp. Cohen 244.
- 5020-1. *Obv.* A a. One ∪ PLG.
 Cohen 245.
- 5022-4. *Obv.* B c.
 Cohen 246.
- 5025-8. Similar, but *obv.* details uncertain. One TRP, one •TRP•,
 one $\frac{S}{PLG}$.
5029. *Obv.* D N CONSTANTINVS P F AVG. Head, laureate, r.
 Cohen 249.
5030. *Obv.* IMP CONS . . . Bust c.
Rev. SCONST.
- 5031-6. *Obv.* D c.
Rev. One each SMH (or N) A, •TRP•, •TRS•, SMTSA.
 Cohen 250. (= I 564).
- 5037-9. Similar, but the standard ornamented with the mono-
 gram of Christ. One PLG, one •PLG.
 Cohen 251.
5040. As Cohen 244-251.
Reverse: Two Standards between Soldiers.
- 5041-57. *Obv.* A c.
Rev. Four PLG. Six are 3 Æ Q, one of which has *obv.*
 CONSTANTINVS VG. Another coin has CON-
 STANTINS AVG.
 Cohen 253.

- 5058-77. (= I 562-3). One each $\overline{\text{CON—}}$, $\overline{\text{PCONST}}$, $\overline{\text{PLG}}$, $\overline{\bullet\text{PLG}}$,
 $\overline{\text{SPLG}}$, $\overline{\cup\text{PLG}}$, $\overline{\text{—SIS}}$, $\overline{\text{SMTS}\Gamma}$, $\overline{\text{TR}\bullet\text{P}}$, $\overline{? \text{TR}\bullet\text{S}}$,
 $\overline{\text{TR}\bullet\text{—}}$, two $\overline{\text{TR—}}$. 4*.
5078. *Obv.* Apparently . DNSI ANNA . . . in large square letters,
no doubt [C]ONSTANTIN . . . blundered.
Rev. Similar. [Plate xxxvii, 20].
- *5079. ? Similar, but *obv.* B. Local imitation. $\overline{\text{TRP}}$. Ovoid.
Cp. Cohen 252.
- 5080-2. (= I 561). Two $\overline{\text{TRP}}$, one $\overline{\text{TRP}\bullet}$.
- *5083. *Obv.* CONSTANTINVS A. Bust a. $\overline{\text{TRS}}$. Small and
barbarous.
- 5084-8. *Obv.* D c.
Rev. Similar, but emblem between standards. One each
- 

$\overline{\text{PCONST}}$ $\overline{\text{TRP}}$ $\overline{\text{TRS}}$
- Cohen 256.
5089. *Obv.* B d.
Rev. MARTI CONSERVATORI. Mars, in military dress,
standing r., holding reversed spear and leaning on
shield. $\overline{\text{PTR}}$.
- Cohen 338.
5090. *Obv.* FL VAL CONSTANTINVS NOB C. Bust b.
Rev. MARTI PATRI CONSERVATORI. Similar. $\overline{\text{S}\overline{\text{M}}}$
 $\overline{\text{PTR}}$.
- Cohen 358. Follis.
5091. *Obv.* Similar.
Rev. MARTI PATRI PROPVGNATORI. Mars, with cloak
blowing behind him, striding r. in a threatening
attitude, and holding transverse spear and shield.
 $\overline{\text{S}\overline{\text{A}}}$
 $\overline{\bullet\text{PTR}}$
- Cohen 366. Follis.
5092. *Obv.* [A].
Bust, cuirassed, l., with laureate helmet, holding spear and
shield.
Rev. PRINCIPI IVVENTVTIS Constantine standing l., in
military dress, wearing cloak and holding globe
and reversed spear. $\overline{\text{PLN}}$ $\overline{\text{—}|\text{—}}$ *
- Cohen 428.

182 REPORTS OF THE SOCIETY OF ANTIQUARIES

5093. *Obv.* B b.
Rev. Similar.
 Cohen 429.
- 5094-7. *Obv.* A. Head, laureate, r.
Rev. PROVIDENTIAE AVGG. Gate of camp crowned by
 two towers. Star above. $\overline{\text{PTRE}}$ (2), $\overline{\text{STRE}}$ (1),
 one ? PLG.
 Cohen 454. I*.
5098. *Obv.* A. Head, laureate or diademed, r.
Rev. PROVIDENTIAE CAESS. Similar, but star above
 between two globes.
 Cohen 462.
- 5099-102. (= I 565-6). One $\overline{\text{PTRU}}$, $\overline{\text{STRU}}$.
- 5103-5. *Obv.* A d.
Rev. SOLI INVICTO. Sun-god, radiate, standing l.,
 raising r. hand and holding globe in l. Two
 $\overline{\text{PTR}}$, one $\frac{\text{T|F}}{\text{—N}}$.
 Cohen 508.
- 5106-8. *Obv.* IMP CONSTANTINVS P F AVG. Bust d.
Rev. SOLI INVICTO COMITI. Sun-god, radiate, standing
 to front, looking l., raising r. hand and holding
 globe; to l. a captive seated on ground with
 hands bound behind back. One $\frac{\text{T}}{\text{PLG}}$.
 Cohen 519.
- 5109-11. Similar, but details of types obscure.
 Cohen 518-19.
5112. *Rev.* Similar, without captive. $\overline{\text{TF}}$ *. Reverse brockage.
 Cp. Cohen 521.
5113. *Obv.* C b.
Rev. Similar. $\overline{\text{PLN}}$.
 Cohen 524.
- 5114-19. (= I 569). One each $\overline{\text{QARL}}$, $\overline{\text{PTR}}$, $\frac{\text{T|F}}{\text{STR}}$, $\frac{\text{T|F}}{\text{—}}$, $\frac{\text{F|T}}{\text{STR}}$.
- 5120-5. (= I 567-8). Three $\frac{\text{S|F}}{\text{PLN}}$, one $\overline{\text{ATR}}$, one $\overline{\text{PLG}}$.
- 5126-7. Similar, but larger module. Both $\frac{\text{T|F}}{\text{PTR}}$.

5128. *Obv.* IMP CONSTANTINVS P F AVG. Bust a, b, or d.
Rev. Similar. $\overline{\text{X}}$.
 Cohen 536.
5129. *Obv.* Similar. Bust a.
Rev. Similar, but sun-god moving l., globe in l. hand.
 Cohen 546.
5130. Similar, but sun-god has whip in l. $\overline{\text{F|T}}$
 PLG .
 Cohen 546.
5131. *Obv.* Top of diademed head r.
Rev. Top half of figure standing l., probably sun-god.
 Minim.
5132. *Obv.* [D]. Bust, cuirassed, r., with laureate helmet.
Rev. VICTORIAE LAETAE PRIN P: Two Victories setting
 a shield on an altar [on the altar VOT P R].
 Cp. Cohen 629.
- 5133-5. *Obv.* A. Bust, cuirassed, r., with crested helmet.
Rev. VICTORIAE LAETAE PRINC PERP. Similar, but
 VOT P R on the shield.
 Cohen 631 foll.
5136. *Obv.* ? D. End of legend blundered. Bust r. with
 laureate helmet.
Rev. Similar with symbol on altar. $\overline{? \text{PLN}}$.
 Cp. Cohen 635.
- 5137-9. (=I 571-2). One $\overline{\text{T}}$.
- 5140-2. *Obv.* E. Bust, cuirassed, l., with crested helmet, and
 spear on r. shoulder.
Rev. Similar, VOT P R on shield, garland? on front of
 altar. One $\overline{\text{PLN}}$.
 Cohen 638. 1*.
- 5143-6. (=I 573). Helmet, laureate, but altar plain on at
 least one. One Lyon, one $\overline{\text{PT}}$. 1*.
- *5147. *Obv.*NTINVS A. Bust ? a.
Rev. VICTORIAE LAETAE PRINC. Plain altar. $\overline{\text{TR}}$.
 Semi-barbarous.
- *5148. *Obv.* D N CON . . . AV. Bust c.
Rev. Illegible. Imitating preceding types, but cippus for
 altar. $\frac{\text{N|S}}{\text{TR}}$. 3 Æ Q.

184 REPORTS OF THE SOCIETY OF ANTIQUARIES

5148 a. Apparently types of Cohen 671 with helmeted bust r.,
and Mars striding r., carrying spear and trophy.
Rev. Legend I I I I . . .

5149-50. *Obv.* D N CONSTANTINVS P F AVG. Head, laureate, r.
Rev. VIRTVS AVGVSTI. Constantine standing to front
in military dress, looking r., holding reversed
spear and leaning on shield.
Cohen 677.

5151. Similar, but bust cuirassed, r.

5152. Similar, but *obv.* D N CONSTANTINVS AVG.

5153. *Obv.* A. Bust, helmeted and cuirassed, r.
Rev. VIRTVS EXERCIT. Standard, at the foot of which
are seated two captives in an attitude of dejection.
* On the standard, VOT XX. STR.
Cohen 690.

5154. *Obv.* IMP CON . . . AVG. Bust, r.
Rev. VOTIS X in wreath.
Not in Cohen.

5155-6. *Rev.* VOT XX MVLT XXX. Perhaps Constantine I.

5157-8. ? Mules of Constantine I and Victory reverse of 'Con-
stantinopolis' without legend. One 3 Æ Q.

5159-60. Unclassified : one early.

Consecration Coins. A.D. 337

5161-70. (= I 575-6). One SMANΔ, one RP, one TRP. 3*.

5171. *Obv.* DIVO CONSTANTINO AVG. Bust, veiled and
draped, r.
Rev. Similar.

5172-4. (= I 577).

Constantinopolis

5175-8. *Obv.* CONSTANTINOPOLIS. Bust of Constantine
to l., wearing laureate helmet and imperial mantle,
and holding a sceptre.

Rev. GLORIA EXERCITVS. Two helmeted soldiers
standing, each holding erect spear and resting
hand on rim of shield : between them a standard.

Two PLG, one TRP. All 3 Æ Q. One barbarous.
Cohen 4.

5179. Similar, but *Obv.* $\Sigma\text{VIP}\Sigma\text{IN}$ l. of bust.
5180. Similar: minim.
5181. Similar, but two standards. The obverse legend is too long for Cohen's *Roma* 2.
5182. Similar: two standards. Obverse legend clear. $\overline{\text{TRP}}$.
5183. Similar: *obv.* legend barbarous. Perhaps Cohen's *Roma* 2.
5184. *Obv.* CONSTANTINOPOL. Bust, helmeted and cuirassed, r.
Rev. GLORIA EX. This is the entire legend and fills all the available space. Soldiers guarding two standards. $\overline{\text{TRS}}$. 15 mm.
5185. *Obv.* CONSTANTINOPOLII. Diademed and cuirassed bust, r.
Rev. GLORIA EXERCITVS. Soldiers guarding two standards. $\overline{\text{TRP}}$.
- 5186-578. *Obv.* CONSTANTINOPOLIS. Bust of Constantinopolis, helmeted, l., with sceptre over shoulder.
Rev. Victory standing l., with spear and shield, placing r. foot on prow of vessel. (= I 578-622.)
- 5186-7. 18-20 mm. $\overline{\text{TRP}}\bullet$ (1). 1*.
- 5188-263. 16-18 mm. 5*.
- Aquileia (1) $\overline{\text{AQS}}$.
- Arles (2) $\overline{\text{PCON}}$ (1), $\overline{\text{SCONS}}$ [? T] (1).
- Heraclea (1) $\overline{\text{SMHD}}$.
- Lyon (6) $\overline{\text{PLG}}$ (2), $\bullet\overline{\text{PLG}}$ (2), $\cup\overline{\text{PLG}}$ (1), $\overline{\text{LG}}$ (1).
- Rome (1) $\overline{\text{R}\ast\epsilon}$.
- Siscia (1) $\bullet\overline{\text{BSIS}}$.
- Thessalonica (1) $\overline{\text{NTS}}$.
- Trèves (32) $\overline{\text{TRP}}$ (9), $\overline{\text{TR}\bullet\text{P}}$ (3), $\overline{\text{TRP}}\bullet$ (8),
 $\overline{\text{TRP}}\ast$ (2), $\overset{\Omega}{\overline{\text{TRP}}}$ (1), $\overline{\text{TRS}}$ (5), $\overline{\text{TR}\bullet\text{S}}$ (1),
 $\overline{\text{TRS}}\bullet$ (1), $\overline{\text{TR}}\text{---}$ (2).
- 5264-380. 13-16 mm. 27*.
- Lyon (27) $\overline{\text{PLG}}$ (19), $\cup\overline{\text{PLG}}$ (1), $\bullet\overline{\text{PLG}}$ (5),
 $\bullet\overline{\text{PLG}}\bullet$ (1), $\overline{\text{PLG}}\bullet$ (1).
- Thessalonica (1) $\overline{\text{TS}}$.
- Trèves (18) $\overline{\text{TRP}}$ (9), $\overline{\text{TR}\bullet\text{P}}$ (2), $\overline{\text{TRP}}\bullet$ (2), $\overline{\text{TRS}}$ (3),
 $\overline{\text{TR}\bullet\text{S}}$ (1), $\overline{\text{TR}}\text{---}$ (1).

5381-529. 10-13 mm. 1*.

Arles (1) —CON.

Lyon (38) $\overline{\text{PLG}}$ (30), $\overline{\text{PJG}}$ (1), $\overline{\text{DJG}}$ (1), $\overline{\text{PTG}}$ (1),
 $\bullet\overline{\text{PLG}}$ (3), $\overline{\text{PLG}}$ (1), $\overline{\text{SLG}}$ (? 1).Trèves (26) $\overline{\text{TRP}}$ (4), $\overline{\text{TRP}}$ (2), $\overline{\text{PTR}}$ (2), $\overline{\text{TRS}}$ (9),
 $\overline{\text{TRS}}$ (1), $\overline{\text{TR}}$ (8).

One of Lyons and two of Trèves are barbarous. Two coins have obverse legends (1) . . . TIN, (2) $\overline{\text{CONSTANTINOPLE}}$ counter-clockwise with the bases of the letters outwards.

Some coins have shortened legends. The modules of Cohen's 21 and 22 pass insensibly one into the other, Trèves predominating in the larger, which also includes the few Italian and eastern coins, and Lyon in the smaller though less markedly. Arles is almost entirely absent.

5530-53. Minims of 8-10 mm. $\overline{\text{TR}}$ (1), $\overline{\text{TR}}$ (1), $\overline{\text{ALG}}$ (1).

One bust apparently bearded and helmeted, top of Victory only with widespread wings.

5554-6. Minims of 7-8 mm.

5557-8. Minims of 6-7 mm.

5559-78. Unassigned to modules.

Mint marks unassigned to modules include

 $\overline{\text{A}]\text{RL}}$ (1), $\overline{\text{PLG}}$ (13), $\bullet\overline{\text{PLG}}$ (1), $\overline{\text{QT}}$ (1), $\overline{\text{TRP}}$ (4),
 $\overline{\text{TRP}}$ (1), $\overline{\text{TR}\bullet\text{P}}$ (2), $\overline{\text{TRS}}$ (4), $\overline{\text{TR}\bullet\text{S}}$ (1), $\overline{\text{TR}\ast\text{S}}$ (1).

5579. *Obv.* Bearded head l., eye protruding and formed by circle. Type copied from Constantinopolis coins: traces of helmet behind head.

Rev. Victory with widely outspread wings.

5580-2. As I 578-622, but bust r.

Cohen 23. One without sceptre.

5583. *Obv.* Helmeted head, r.

Rev. Figure standing l., holding transverse sceptre in l. and ? branch in r. ? 'Constantinopolis' type.
3 ÆQ.

5584. Constantinopolis type: barbarous.

5585. *Obv.* Blundered legend. Diademed head l.

Rev. 'Constantinopolis' Victory type with top off flan.
Minim.

5586-7. Minims. One CA l. of head of Victory.

5588-90. *Obv.* Bust, diademed, r., not helmeted.

Rev. 'Constantinopolis' Victory. Two $\overline{\text{PLG}}$. Minims.
1*.

5591-7. *Obv.* CONSTANTINOPOLIS. Helmeted bust.

Rev. She-wolf r., suckling Romulus and Remus: two stars above. 2 $\overline{\text{PLG}}$, 3 $\bullet\overline{\text{PLG}}$, 1 $\overline{\text{PLG}}$, 1 $\overline{\text{PRS}}$ (*sic*).

Cohen 24.

Urbs Roma

5598-601. *Obs.* VRBS ROMA. Bust of Roma l., wearing crested helmet and imperial mantle.

Rev. GLORIA EXERCITVS. Two soldiers standing to front, helmeted, each with spear and leaning on shield. Between them two standards.

Cohen 2.

5602. *Obv.* Helmeted bust r., ? of Roma.

Rev. Similar.

5603-11. *Obv.* As 5598-601.

Rev. No legend. Victory l., setting l. foot on prow of vessel, holding transverse spear and resting hand on shield. 3 are 3 $\overline{\text{Æ Q}}$, 1 $\overline{\text{TR}\cdot\text{P}}$, 1 $\overline{\text{TR}}\text{—}$, 2 $\overline{\text{PLG}}$.

Cohen 12.

5612. Similar, but *Obv.* Bust r. and ROMA-VRBS to l. and r. of head.

5613-14. *Obv.* Legend blundered. Bust of Roma l.

Rev. No legend. Two soldiers, each with spear and shield: one standard between them.

Cp. Cohen 14.

5615-95. (= 1636-84). Larger module of Cohen 17. Wreath or palm where quoted are between the two stars

above the wolf. 1 $\overline{\text{SCONST}}$, 2 $\frac{\text{Q}}{\overline{\text{SCONST}}}$, 1 $\frac{\text{O}}{\overline{\text{SCONST}}}$,
1 $\overline{\text{CONST}}$, 1 $\overline{\text{SMKA}}$, 2 $\overline{\text{PLG}}$, 5 $\overset{\circ}{\overline{\text{PLG}}}$, 2 $\overset{\smile}{\overline{\text{PLG}}}$, 1
 $\overline{*PLG}$, 1 $\overline{\text{SLG}}$, 2 $\overline{\text{RBQ}}$, 1 $\overline{\text{R}}\text{—}\overline{\text{Q}}$, 6 $\overline{\text{TRP}}$, 1 $\frac{\text{palm}}{\overline{\text{TRP}}}$,
1 $\frac{\text{Q}}{\overline{\text{TRP}}}$, 9 $\overline{\text{TR}\cdot\text{P}}$, 4 $\overline{\text{TRP}}$, 2 $\overline{\text{TRP}*}$, 6 $\overline{\text{TRS}}$, 2 $\frac{\text{Q}}{\overline{\text{TRS}}}$,
1 $\overline{\text{TR}\cdot\text{S}}$, 2 $\overline{\text{TRS}}$, 1 $\overline{\text{TRS}*}$, 2 $\frac{\text{Q}}{\overline{\text{TR}}\text{—}}$, 2 $\frac{\text{Q}}{\text{—}}$, 1 $\frac{\text{palm}}{\text{—}}$.

188 REPORTS OF THE SOCIETY OF ANTIQUARIES

5696-795. (= I 636-84). Middle module. Cohen 18,
 1 $\overline{\text{PLVG}}$, 25 $\overline{\text{PLG}}$, 6 $\bullet\overline{\text{PLG}}$, 2 $\cup\overline{\text{PLG}}$, 1 $\overline{\text{—LG}}$, 1 $\overline{\text{CLP}}$.
 1 $\overline{\text{Z15}}$, 1 $\overline{\text{PTR}}$, 8 $\overline{\text{TRP}}$, 3 $\overline{\text{TR}\bullet\text{P}}$, 4 $\overline{\text{TRS}}$, 3 $\overline{\text{TRS}}$, 2 $\overline{\Omega}$.

5796-887. (= I 636-84). Smallest module, Cohen 19: in-
 cluding many 3 $\overline{\text{Æ Q}}$. A few barbarous. 1 $\overline{\text{CON}}$,
 25 $\overline{\text{PLG}}$, 1 $\bullet\overline{\text{PLG}}$, 1 $\cup\overline{\text{PLG}}$, 1 $\overline{\text{—P}\bullet\text{LG}}$, 1 $\overline{\text{TRP}}$, 3 $\overline{\text{TRS}}$,
 2 $\overline{\text{TR—}}$. The three modules, Cohen 17-19, fade
 imperceptibly into one another. The largest
 module is much more characteristic of Trèves
 and the smallest of Lyon than in the case of the
 Constantinopolis types.

*5888-907. (= I 636-84). Various modules not classified by
 mints. Sizes in mm. 17 mm. (4), 16 (2), 15 (5),
 14 (3), 13 (5) 9 (1). 1 $\overline{\text{—CONST}}$, 4 $\overline{\text{PLG}}$ including
 the smallest, 2 $\bullet\overline{\text{PLG}}$, 1 $\overline{\text{TRP}}$, 4 $\overline{\text{TRS}}$, $\bullet\overline{\text{TRP}}$. One
 at least barbarous.

5908-9. Similar, but bust r. 3 $\overline{\text{Æ Q}}$. 1*.
 Cp. Cohen 16 for type.

5910. *Obv.* s. Head or bust of one of the Constantine
 family.
Rev. Similar $\overline{\text{RQ—}}$. 3 $\overline{\text{Æ Q}}$. Barbarous.

5911-17. Minims of type I, 636-84. Bust of one ornamented
 with dots. One $\overline{\text{TR—}}$.

5918. Similar to I 636-84, but wolf to r.
 Cohen 20.

Pop. Romanus

5919-23. (= I 694). 1 $\overline{\text{CONS}}$ _Z, 1 $\overline{\text{CONSA}}$. 1*.

5924-33. (= I 692-3). 2 $\overline{\text{CONSA}}$, 1 $\overline{\text{CONSB}}$, 1 $\overline{\text{CONSG}}$, 2 $\overline{\text{CONSZ}}$,
 1 $\overline{\text{CONSO}}$. 1*.

Fausta (wife of Constantine I, A. D. 307-326)

5934. *Obv.* FLAV MAX FAVSTA AVG. Bust with waved hair r.
Rev. SALVS REIPUBLICAE. Fausta standing to front
 looking l., holding in her arms the children
 Constantine II and Constantius. $\overline{\text{PLON}}$.
 Cohen 6.

5935. *Obv.* Similar.

Rev. SPES REIPUBLICAE. Similar. S∨T.

Cohen 15.

Crispus (Caesar A.D. 317-326)

5936-7. *Obv.* CRISPVS NOB CAES. Bust, laureate, cuirassed, l., holding spear and shield.

Rev. BEATA TRANQVILLITAS. On altar, which is inscribed VOTIS XX, a globe. Three stars above.

PTR. One uncertain.

Cohen 7.

5938. ? Similar, but bust helmeted and cuirassed r.

Cohen 8.

5939-40. *Obv.* CRISPVS NOBIL C. Bust, laureate and cuirassed, l., holding spear and shield.

Rev. Similar. One $\frac{F|B}{PLON}$.

Cohen 11.

5941-2. Similar, but helmeted and cuirassed l., without spear and shield. $\frac{P|A}{PLON}$.

Cohen 13.

*5943. *Obv.* CRISPVS NOB CAES. Bust, laureate and cuirassed, l., with shield and horse.

Rev. Similar. PTR.

Not in Cohen.

5944. *Obv.* IVL CRISPVS NOB C. Bust, laureate and cuirassed, r.

Rev. Similar. •STR∨.

Cohen 17.

5945. *Obv.* IVL CRISPVS NOB CAES. Bust, laureate, cuirassed, l., with spear and shield.

Rev. Similar STR. 1*.

Cohen 22.

*5946. *Obv.* CRISPVS NOBIL C. Bust, laureate and cuirassed l., with shield and spear, seen from behind.

Rev. BEAT TRANQLITAS (*sic*). Similar. $\frac{F|B}{PLON}$.

Cohen 27.

190 REPORTS OF THE SOCIETY OF ANTIQUARIES

5947. (= I 717). $\overline{\text{AQS}}$.

5948-9. *Obv.* IVL CRISPVS NOB C. Head, laureate, r.
Rev. CAESARVM NOSTRORVM. In laurel wreath VOT X.
 $\overline{\text{PCON}}$, $\overline{\text{STR}}$.

Cohen 44.

5950. Similar, but bust, laureate, cuirassed, r. $\overline{\text{STR}}$ •.
 Cohen 45.

5951. *Obv.* FL IVL CRISPVS NOB CAES. Similar.
Rev. CLARITAS REIPUBLICAE, Sun god, radiate, standing l., raising r. hand and holding globe in l.
 Cohen 52.

5952. *Obv.* CRISPVS NOB CAES. Bust, laureate, cuirassed, l.
Rev. PROVIDENTIAE CAESS. Camp gate crowned by two towers, between which a star.
 Cohen 117.

5953. *Obv.* CRISPVS NOB CAES. Bust, helmeted, cuirassed, r.
Rev. VIRTVS EXERCIT. Standard with captives seated at foot, the one to l. in attitude of dejection, the one to r. with hands bound behind back.
 Cohen 172.

5954. Unclassified.

Delmatius (Caesar, A. D. 335-7)

5955-6. *Obv.* FL DELMATIVS NOB C. Bust, laureate, draped or cuirassed, r.
Rev. GLORIA EXERCITVS. Two soldiers helmeted standing, each holding a spear and resting hand on shield; a military standard between them with a banner at the top of the staff.

Cohen 4.

5957-8. (= I 718). I ✠ on banner, and $\overline{\text{SCONST}}$; I ✠ $\overline{\text{PLG}}$.

Constantine II (Caesar, A. D. 317; Augustus, A. D. 337-40)

5959. *Obv.* CONSTANTINVS IVN N C. Bust r.
Rev. BEAT. TRANQVILLITAS. Type I 719 (altar and globe).

Cohen 5-7.

*5960. (= I 719). $\overline{\text{PLON}}$.

5961. Similar, but bust l. . . . QLTAS. PLON.
Cp. Cohen 10.
5962. *Obv.* Similar, but bust, laureate and draped, r.
Rev. BEATA TRANQVILLITAS. Same type. $\frac{C|R}{PLG}$.
Cohen 11.
5963. Similar, but bust, radiate, draped, l. $\frac{P|A}{PLON}$.
Cohen 16.
5964. CONSTANTINVS IVN NOB C. Bust, laureate, l., with
imperial mantle, holding sceptre surmounted by
eagle.
Rev. Similar. $\overline{\bullet PTR}$.
Cohen 22.
- 5965-6. *Obv.* Same legend. Half-length bust, laureate, l., with
imperial mantle, holding globe surmounted by
Victory and *mappa*.
Rev. Similar. \overline{LON} , $\overline{\bullet STR}$.
Cohen 23.
5967. Similar, but bust, helmeted and cuirassed, r. \overline{PTR} .
Cohen 25.
- 5968-70. (= I 720). One \overline{PLON} , one \overline{PTR} .
5971. Similar, but bust, laureate and cuirassed, r. $\overline{—TR}$.
Cohen 39.
5972. Similar, but laureate head, and NOB CAE. \overline{TVA} .
Not in Cohen.
5973. ? Similar, but *rev.* VOT XX.
Cp. Cohen 43.
- 5974-6043. *Obv.* CONSTANTINVS IVN NOB C.
Rev. Soldiers guarding two standards. (= I 721-34).
11*.
1 $\overline{—MAQ—}$, 1 \overline{CON} , 12 \overline{PLG} , 2 $\overline{\bullet PLG}$, 1 $\overline{\smile PLG}$, 1 $\overline{PLG\bullet}$,
2 $\overline{\bullet SLG}$, 1 $\overline{—SIS}$, 1 \overline{CSIS} , 1 \overline{RFT} , 1 \overline{TSP} , 2 \overline{TRP} ,
1 \overline{TPP} , 2 $\overline{TR\bullet P}$, 1 \overline{TRS} , 2 $\overline{TRS\bullet}$, 2 $\overline{TR—}$, and 5 others
Trèves.
Cohen 122. Small 3 Æ, but very few 3 Æ Q.

192 REPORTS OF THE SOCIETY OF ANTIQUARIES

6044. *Obv.* CONSTANTINO NO. Similar bust l.

Rev. Similar. 3 Æ Q.

?Cohen 123, blundered.

6045-104. *Obv.* CONSTANTINVS IVN N C. Some variants of end of legend, IVN NO C, IV NOB C, IV N C, I NOB C IIIINI. Bust, laureate and cuirassed, r.

Rev. Similar. (= I 721-34). All small module down to many 3 Æ Q.

Cohen 124. 4*.

14 $\overline{\text{PLG}}$, 1 $\overline{\bullet\text{PLG}}$, 1 $\overline{\text{—LG}}$, 1 $\overline{\text{R}\ast\text{P}}$, 1 $\overline{\text{—RQ}}$, 1 $\overline{\text{SISC}}$, 2 $\overline{\text{TRP}}$,
1 $\overline{\text{TR}\ast\text{P}}$, 1 $\overline{\text{TRP}\bullet}$, 3 $\overline{\text{TRS}}$, 1 $\overline{\text{TR—}}$.

*6105. *Obv.* CONSTANTINVS IVN N C. Bust similar.

Rev. Similar. ? $\overline{\text{TRS}}$.

6106. Similar, but ? emblem in field between standards. $\overline{\text{SCONST}}$.
?Cohen 126.

6107-9. Similar, but NOBC and wreath (2 $\overline{\text{TRP}}$) or palm branch
(1 $\overline{\text{PCONST}}$) between standards.

Cohen 127.

6110. *Obv.* FL IVL CONSTANTI[NVS NOB C]. Bust, ?laureate and draped, r.

Rev. Similar, but no emblem.

?Cohen 129.

6111. *Obv.* [CO]NNTIIIIIIIIIS.

Rev. Similar.

6112-19. *Obv.* CONSTANTINVS IVN N C. Bust, laureate, draped, r. One legend ends IVNB.

Rev. Similar, but one standard. (= I 736-7). 1 $\overline{\text{PLG}}$,
1 $\overline{\text{TRP}}$, 1 $\overline{\text{TRP}\bullet}$, 1 $\overline{\text{—TR}}$. 1 3 Æ Q.

Cohen 113.

6120-34. *Obv.* CONSTANTINVS IVN NOB C. Bust, draped or cuirassed.

Rev. Similar. (= I 736-7). 2 $\overline{\text{PLG}}$, 1 $\overline{\ast\text{PLG}}$, 1 palm
 $\overline{\text{PLG}}$, 1 $\overline{\text{TRP}}$, 3 $\overline{\bullet\text{TRS}}$, 1 $\overline{\text{—TR}\ast}$, 1 $\overline{\text{TR—}}$.

Cohen 114.

6135-7. (= I 736-7). 1 $\overline{\text{—TR}}$, 1*.

6138-41. *Obv.* CONSTANTINVS IVN N C. Bust, laureate and cuirassed, r.

Rev. Similar, but ✱ on banner. I —MPL, I TRP, I TRS.
Cohen 119.

6142-3. *Obv.* CONSTANTINVS IVN NOB C. Similar.

Rev. Similar. One TRP.
Cohen 120.

6144. *Obv.* . . . STANT! . . .

Rev. Soldiers and one standard. Minim.

6145-6. (= I 738). Both PTR[∩].

Cohen 165.

6147. *Obv.* CONSTANTINVS IVN NOB C. Bust, laureate, draped, r.

Rev. Victory l., with l. on rim of shield [holding palm in r., at her feet prow of ship].

Cp. Cohen 281.

6148. *Obv.* CONSTANTINVS IVN NOB C. Bust, laureate and cuirassed, r.

Rev. Wolf suckling twins. Two stars above. TRS.
Cohen 284.

As Augustus

*6149-50. *Obv.* CONSTANTINVS AVG. Bust, diademed and draped, r.

Rev. GLORIA EXERCITVS. One standard between soldiers. CON, TRP[✱]. X on standard.

Cp. Cohen 117.

Constantius II (Caesar A.D. 323, Augustus A.D. 337-61)

As Caesar

6151-67. (= I 743). Soldiers guarding two standards. I PLG,
I RRT, I TR—, I TR•P, 2 TRS, I TRS. One with blundered legend, perhaps overstruck.

6168. Similar, but *Obv.* CONSTANTIVS N C.

6169. Similar, but CONTANTIVS NOB C. TR.

6170. Similar, but *Obv.* ?CONSTANTIVS IV NOB C.

Rev. . . . EXEROIS.

6171. Similar, but CONSTATIVS (*sic*). Broken, ?NOB C or AVG.

194 REPORTS OF THE SOCIETY OF ANTIQUARIES

6172-9. Similar to I 744-5, but emblem between standards.

1 $\frac{*}{\text{SCON—}}$, 1 $\frac{\Omega}{\text{SCONST}}$, 2 $\frac{\text{palm}}{\text{SCONST}}$, 1 $\frac{\cup}{\text{PLG}}$, 1 $\frac{\Omega}{\text{—}}$
Cohen 105.

6180. Similar, or as I 743.

6181. (= I 744-5). *Obv.* twice struck.

6182-97. *Obv.* Similar, but eight illegible and possibly P F AVG and I 770. Bust, laureate, draped, and cuirassed, r., or one at least cuirassed only.

Rev. Similar, but one standard. 1 $\overline{\text{CON}}$, 1 $\overline{\text{SCON}}$, 2 $\overline{\text{TRP}}$.
Cohen 92.

6198. *Obv.* Similar.

Rev. PROVIDENTIAE CAES. Camp gate open, crowned by two towers: a star above. $\overline{\text{STR*}}$.
Cohen 167.

6199. *Obv.* Similar. Bust, laureate and draped, l., holding shield.

Rev. PROVIDENTIAE CAESS. Similar. $\overline{\text{STRE}}$.
Variant of Cohen 170.

6200. *Obv.* Similar. Bust, laureate, draped, r.

Rev. SECVRITAS REIPVB. Securitas standing to front with legs crossed, looking r., holding sceptre and leaning on column. $\overline{\text{R}\Phi\text{S}}$.
Cohen 183 var.

As Augustus

6201-3. *Obv.* D N CONSTANTIVS P F AVG. Bust, diademed, draped, and cuirassed, r. A behind head on one.

Rev. FEL TEMP REPARATIO. Constantius, laureate, in military dress, standing on a vessel moving l., holding a Victory. To r. Victory seated l. and holding the helm. Two of large module (Mionnet 6), both TRP, have no A behind head.

6204. Barbarous imitation of preceding.

6205. *Obv.* CONSTANTIVS P F AVG. Bust, diademed and draped, r. Without A.

Rev. Similar. $\overline{\text{AQP}}$.
Cohen 34.

6206-7. D N CONSTANTIVS P F AVG. Same bust.

Rev. Similar, but Constantius holds phoenix instead of Victory.

Cohen 36. One 2 Æ large, one 3 Æ.

FEL TEMP REPARATIO types

Obv. Bust, diademed and draped, r.

Rev. Legionary l., spearing falling horseman who raises l. arm.

6208-18. (= I 753-8). I $\overline{\text{CONST}}$, I $\overline{\text{CPLG}}$, I $\overline{\text{PLG}}$, I $\overline{\text{—SLG}}$,
I $\overline{\text{CSLG}}$, I $\overline{\text{TRP}}$, I $\overline{\text{TR—}}$. I*. 3 Æ Q.

6219. Large module.

Cohen 44.

6220-92. (= I 763-5). Thirty-one probably Cohen 45, fourteen Cohen 48.

I $\overline{\text{AQT}}$, I $\overline{\text{SCON}}$, I $\overline{\text{CON}}$, I $\overline{\text{PLG}}$, I $\overline{\bullet\text{PLG}}$, I $\overline{\sim\text{PLG}}$, I $\overline{\text{RPLG}}$,
2 $\overline{\text{CSLG}}$, I $\overline{\text{CS—}}$, I $\overline{\text{LVG}}$, I $\overline{\text{TR—}}$, I $\overline{\text{TRP}}$, I
 $\overline{\text{—TR}}$. Four 2 Æ, sixteen 3 Æ Q, the remainder
3 Æ, mostly small.

6293. Similar. *Obv.* . . CONSTIIV—TIVS P . . .

Rev. . . LTEM. Barbarous. [Plate xxxvii, 21.]

6294. Similar. *Obv.* D N CNSTANTI . . and blundered *rev.* legend. The *rev.* type is l. to r., the legionary being on l., facing r., and legend OITARA to l.

6295. Similar. *Obv.* . . . ANTIV, no letters after.

6296. Similar. *Obv.* . . . TIVS AG.

Rev. . . . RAT ends, $\overline{\text{TRS}}$.

6297. Similar. *Obv.* D N COSTANTIVS P F AVG.

Rev. $\overline{\text{PLG}}$.

6298. Similar. *Obv.* IV P F AVG.

6299. Similar. *Rev.* REPARTIO.

6300. Similar. *Obv.* D N CONSTATIVS . . .

Rev. in rather high relief.

6301. Similar. *Obv.* D N CONT—. . .

Rev. . . . PARATIO, $\overline{\text{—LG}}$. Barbarous.

6302. Similar. *Obv.* . . . TIVS P F I.

Rev. REPARA r. of type. [Plate xxxvii, 22.]

6303. Similar. *Obv.* CONSTA—TVS P F AVG.

Rev. PLG.

6304. Apparently similar types, but very barbarous.

6305-6. Barbarous imitations with horseman only on flan.

6307. Barbarous minim of type Cohen 48 with *obv.* D N COSTNTS
P F, and *rev.* C—.

6308-10. Similar types. Minims.

*6311. *Obv.* D N CONSTANTIVS P F AVG. Bust same.

Rev. Emperor standing l. with labarum in r. hand and l.
resting on shield: before him two captives.

Large 3 Æ. Cohen 40.

6312. *Obv.* CONSTANTIVS P F AVG. Bust, diademed and
draped l., holding a globe.

Rev. Helmeted soldier striding r., looking back and
dragging a captive out of his hut. The soldier
holds a transverse spear. Behind the hut is a tree.

Cohen 55. 2 Æ.

6313. Similar. 3 Æ.

6314. *Obv.* D N CONSTANTIVS P F AVG. Bust, diademed,
draped, and cuirassed, l., holding a globe.

Rev. Similar. 2 Æ. TRS.

Cohen 56, without N behind head.

6315-20. (= I 766). 1 S•LG.

6321-5. Similar, but Phoenix on funeral pile. 1 TRS•.
Cohen 58.

GLORIA EXERCITVS types

*6326-31. (= I 768-9). 2 TRP, 1 TRP✂, 1 TRS•, 1 TRS✂.

6332-61. (= I 770). 1 SLG, 1 LVG, 8 TRP, •TRP, 1 •TRP✂,
2 TRS, 1 TRS•.

6362-4, *Obv.* CONSTANTIVS AVG. Details obscure.

Cohen 95 foll. 2 TRP, 1 TRS.

6365. Similar. Bust, laureate, draped, r.

6366-9. (= I 773). 1 SLG. 2 ✂ on standard. 2*.

6370. Barbarous imitation of preceding. 3 Æ Q.

6371-84. (= I 774-6). I ? $\overline{\text{TR}}$ — and G on standard, I $\overline{\text{AQP}}$,
 I $\overline{\text{PLG}}$, I $\overline{\text{TRP}}$, I $\overline{\text{TRS}}$, I $\overline{\text{TRS}}$ ∪, I $\frac{\text{II}}{\text{TRS}}$ ∪, 2 $\frac{\text{M}}{\text{TRS}}$,
 I $\frac{\text{G}}{\text{?TR}}$ —, I \otimes . I*.

6385. Similar but bust, laureate and draped, r.
 Cohen 101.

6386-400. (= I 777-9). I $\overline{\text{SIS}}$. I*.

6401. Similar, but *obv.* . . . IVS P F AVG: *rev.* type l. to r. and
 legend retrograde. $\frac{\text{N}}{\text{DIA}}$. [Plate xxxvii, 23].

6402-82. (= I 780-2). Bust, laureate or diademed, draped and
 cuirassed, r. I $\frac{\text{M}}{\text{PARL}}$, I $\frac{\text{M}}{\text{PARL}}$, I $\frac{\text{M}}{\text{PARL}}$, I — $\overline{\text{ARL}}$,
 I $\frac{\text{M}}{\text{M}}$, 4 $\frac{\text{M}}{\text{M}}$, I $\overline{\text{PLG}}$, 2 $\frac{\text{S}}{\text{SLG}}$, 2 $\frac{\text{S}}{\text{T}}$, 2 $\frac{\text{S}}{\text{SLG}}$, I $\frac{\text{D}}{\text{LVG}}$,
 2 $\frac{\text{C}}{\text{LG}}$, 2 $\frac{\text{C}}{\text{SMR}}$, I $\frac{\text{C}}{\text{T}}$, I $\frac{\text{C}}{\text{PTR}}$, I $\frac{\text{C}}{\text{TRP}}$, I $\frac{\text{D}}{\text{TRP}}$, I $\frac{\text{D}}{\text{TRP}}$,
 2 $\frac{\text{leaf}}{\text{TRP}}$, 2 $\frac{\text{leaf}}{\text{TRP}}$, I $\frac{\text{leaf}}{\text{TRS}}$, I $\frac{\text{leaf}}{\text{TRS}}$, I $\frac{\text{leaf}}{\text{TR}}$ —, 3 $\frac{\text{D}}{\text{S}}$, I $\frac{\text{S}}{\text{S}}$,
 4 $\frac{\text{leaf}}{\text{S}}$. 5*.

6483-5. *Obv.* FL IVL CONSTANTIVS AVG. Bust, laureate and
 cuirassed, r.

Rev. VIRTVS AVGG NN. Virtus standing to front looking
 r., holding a reversed spear and resting hand on
 shield. I TRS.

Cohen 303.

6486. [D N CONSTANTIVS P F AVG]. Head, diademed, r.

Rev. VOT. XV. MVLTVS XX. in a laurel wreath. Cp. Tac.
 A. xv, 23, 2: Senatus . . . commendaverat (sc.
 Poppaea in confinement) dis votaue publice
 susceperat, quae multiplicata exsolutaue.

6487-90. Similar, but VOT XX MVLTVS XXX. One each, $\overline{\text{SMAN}}[\text{?S}]$,
 $\overline{\text{SMAN}}\Delta$, $\overline{\text{CON}}\Sigma$. *Obv.* legends all clear.

6491-7. Similar, but *obv.* legends uncertain.

6498-501. Unclassified.

Constans (Caesar A.D. 333, Augustus A.D. 337-50)

As Caesar

- Reverses: GLORIA EXERCITVS. Soldiers guarding two standards.*
6502. *Obv.* CONSTANS[NOB CAES]. Bust, laureate and draped,
r. PLG.
Cohen 69 var., bust.
6503. *Obv.* CONST[ANS IVN] NOB C. Bust, cuirassed, r. TR•P.
6504. Similar. Bust ? draped.
- 6505-6. *Obv.* FL CONSTANS NOB CAES. Bust, laureate,
draped, r. •TR—, PLG.
Cohen 71.
6507. *Obv.* CONSTA . . . Youthful, laureate, draped bust, l.
Rev. Similar. 3 Æ Q.
- 6508-10. *Obv.* FL IVL CONSTANS NOB C. Bust, laureate,
draped, and cuirassed, r. One each PLG, *PLG,
PTR.
Cohen 75.
- One Standard*
- 6511-19. *Obv.* FL CONSTANS NOB CAES or varieties. Bust,
diademed, or laureate and draped, or cuirassed, r.
PLG (1), TRP (1).
Cohen 46-52.
- 6520-2. *Obv.* FL IVL CONSTANS NOB C. Bust, diademed,
draped, or cuirassed, r. One *SLG, one TR—.
Cohen 50.
- 6523-5. *Obv.* FL IVL CONSTANS NOB CAES. Head, laureate,
r. One each TR—, TRS.
Cohen 51.
- *6526. *Obv.* [FL IVL CONST]ANS NOB C. Bust, laureate,
cuirassed, r. CA 3 Æ Q imitation.
Cp. Cohen 52.
- 6527-32. One of preceding three types. One PLG and star on
banner.
6533. Similar: minim.

As Augustus

FEL TEMP REPARATIO types.

Busts, diademed and draped, r.

6534-50. (I 783-4). Legionary spearing horseman. Eight
3 $\overline{\text{Æ Q}}$, including one $\overline{\text{SLG}}$, one $\overline{\text{SI[S]}}$, one $\overline{\text{TR—}}$.
1*.

6551. Similar, but *obv.* $\overline{\text{CONSTANS P AVG}}$, *rev.* $\overline{\text{LVG}}$.

6552. Similar, but *obv.* r. of head $\overline{\text{TAN . .}}$, *rev.* $\overline{\text{FELICITAS}}$.

6553. Similar types, but barbarous.

6554-71. (= I 786-8). Phoenix on globe. 4 $\overline{\text{TRP}}$, 2 $\overline{\text{TRP}}$,
1 $\overline{\text{TRS}}$, 2 $\overline{\text{TR—}}$. 1 * on globe.

6572-90. (= I 789-95). Phoenix on pyre. 2 $\overline{\text{PLG}}$, 2 $\overline{\text{TRP}}$, 2 $\overline{\text{TRP}}$,
1 $\overline{\text{TRP}}$ *, 2 $\overline{\text{TRS}}$ *, 2 $\overline{\text{TR—}}$. 4*.

6591-3. (= I 796, but 2 $\overline{\text{Æ}}$). 1 without A behind head and
 $\overline{\text{PFG}}$, 1 $\overline{\text{SLG}}$.

6594-6. (= I 796). 1 * $\overline{\text{PLG}}$, 3 $\overline{\text{Æ}}$ small, 1 $\overline{\text{—LG}}$, and one
barbarous. 3 $\overline{\text{Æ Q}}$. 1*.

6597. Similar, but Constans holds a globe surmounted by a
Victory in place of a phoenix. 2 $\overline{\text{Æ}}$. A left of
head and $\overline{\text{TR—}}$.

Cohen 11.

6598-602. (= I 797). Two of the larger module, Cohen 18,
 $\overline{\text{BSISAM}}$, $\overline{\text{BSISAP}}$; three smaller, Cohen 19, 1 $\overline{\text{AQS}}$,
1 $\overline{\text{R*Q}}$. 1* large 3 $\overline{\text{Æ}}$.

GLORIA EXERCITVS. *One Standard only*

6603-8. *Obv.* $\overline{\text{CONSTANS AVG}}$. Bust, diademed and draped, r.
One * $\overline{\text{SMANT}}$, one $\overline{\text{PLG}}$, and * on standard, one
 $\overline{\text{SLG}}$.

Cohen 53.

6609. Similar, but $\overline{\text{IMP CONSTANS AVG}}$ and $\overline{\text{PCON}}$.

6610. Similar, but $\overline{\text{CONSTS AVG}}$.

6611-41. *Obv.* $\overline{\text{CONSTANS P F AVG}}$. Bust, laureate or dia-
demed and draped, r.

1 $\overline{\text{AQS}}$, 1 $\overline{\text{SARL}}$, 1 $\overline{\text{PLG}}$, 1 $\overline{\text{TRP}}$, 1 $\overline{\text{TRP}}$ ∩, 4 $\overline{\text{TRS}}$, 2 $\overline{\text{TRS}}$ ∩.
Cohen 54-5. Three 3 $\overline{\text{Æ Q}}$ (one ∩ $\overline{\text{LQ}}$). 1*.

6642-3. One of preceding types.

6644-50. As 6611-43. Cohen 54 foll. One $\overline{\bullet\text{ARL}}$, two $\overline{\text{TRP}}$.

6651-64. (=I 805, but not smaller module). Cohen 57.
 1 $\overline{\text{PARL}}$, 2 $\overline{\text{TRP}}$, 1 $\overline{\text{TRP}\bullet}$, 1 $\bullet\overline{\text{TRP}}$, 1 $\overline{\text{TRP}\cup}$, 3 $\overline{\text{TRS}}$,
 1 $\overline{\text{TRS}\cancel{\text{P}}}$, 1 $\overline{\text{TR}\text{—}}$.

6665-6. (=I 805).

6667-70. Similar, but detail obscure. Cohen 57, foll. 1 $\overline{\text{TRP}}$,
 1 $\overline{\text{TRS}}$.

6671. *Obv.* D N CONSTANS P F AVG. Head, diademed, r.
 $\overline{\text{TRP}\text{—}}$.
 Cohen 60.

6672. *Obv.* D N FL CONSTANS AVG. Bust, diademed and
 draped, r. $\overline{\text{TRS}\cancel{\text{P}}}$.
 Cohen 62.

6673-83. (=I 799-804). 1 $\overline{\text{PLG}}$ and M on standard, 1 $\overline{\text{T}}$
 $\overline{\text{PLG}}$,
 1 $\overline{\text{R}\cancel{\text{Q}}}$, 1 $\overline{\text{M}}$
 $\overline{\text{TRP}}$, 2 $\cancel{\text{P}}$, 1 $\overline{\text{I}}$, 1 $\overline{\text{II}}$. 5*.

6684-5. Similar, 3 $\overline{\text{ÆQ}}$, one —TR .
 Cohen 66.

*6686. ? I 798.

6687. *Obv.* IMP CONS. . . . Diademed bust, r.
Rev. One standard type, $\cancel{\text{P}}$ on standard. $\overline{\text{S CONST}}$.
 Not in Cohen.

6688. Similar, but *obv.* C SAVGGG.
 Not in Cohen.

6689-95. *Obv.* D N FL CONSTANS AVG. Bust, diademed and
 draped, r.

Rev. SECVRITAS REIP. Security standing to front with
 legs crossed, turning r., holding a sceptre and
 leaning on a column.







One $\overline{\text{R}\cancel{\text{P}}\text{—}}$.
 Cohen 102.

6696-702. *Obv.* D N CONSTANS P F AVG. Bust, diademed and draped, r.

Rev. SPES REIPVBLICE. Constans in military dress, standing l., holding globe in r. and reversed spear in l.

One TRP.

6703-873. (= I 808-35). But some are perhaps Cohen 176 without the emblem in the field.

I M SARL, I ARL, I D CON, 3 PLG, I , I T PLG, I LG,
 I , I ROP, I R*E, I SIS, I D TRP, 5 E TRP,
 I M TRP, 5 , I , 9 Φ TRP, I ⚡ TRP, 2 * TRP,
 3 TRP, I TRP, 4 D TRS, I P TRS, 4 , 3 Φ TRS,
 I TRS, I E TR, I M TR, 2 TR, 3 D, I E, 4 N,
 Φ
 I P, I S, 9 , 2 Φ, I , I *, and about twenty more Trèves TRP or TRS marks with various letters in field.

6874. *Obv.* CONSTANS P F AVG. Bust, diademed and draped, r.

Rev. VIRTVS AVGG NN. Helmeted soldier standing r., holding spear and resting hand on shield. TRP.

3 Æ. Cohen *obv.* of 182 with *rev.* and module of 183.

6875-6. Unclassified.

Constantius II or Constans

FEL TEMP REPARATIO types

6877-7414. (= I 839-50). Legionary spearing falling horse-
 man.

6877-901. Large module 3 Æ. I SLG, 2 TRP, 3 bar-
 barous, of which 1 *rev.* TR. 4*.

6902-7095. Small module 3 Æ grading down to 3 Æ Q.
 I PCON, I CON, I C, I LVG, I LVG, 2 PLG, 2 SLG,
 I LG, I ?SISC in barbarous letters, I TRP, I STR,
 I TR, I TRSO and barbarous legend l. of head.
 One overstruck with CON l. of *obv.* 6*.

7096. *Obv.* CON . . in large letters l. of barbarous bust.
Rev. Horseman in middle of field. Same module.
7097. *Obv.* Barbarous legend r. of head imitating VS AVG.
7098. *Obv.* YHI r. of bust.
Rev. Horseman in upper part of flan. [Plate xxxvii, 24].
7099. *Obv.* Very barbarous head with legend of curved strokes to r.
Rev. Horseman to r. on r. of type, legionary to l. [Plate xxxvii, 25].
- 7100-102. Horseman in mid *rev.* field.
- 7103-320. 3 Æ Q. 17*. 1 ALEΔ, 2 LVG, 1 PLG, 1 ·PLG, 1 —LG, 1 CL, 1 R^l—, 1 H, 1 TR—, 1 apparently TR.

Nearly all are more or less barbarous, often parts of obverse and reverse types are off the flan, some have only the legionary or more frequently only the horseman on the reverse.

The following nine coins are of the same module.

7321. *Obv.* . . SP F AG. Wedge-shaped, draped bust, r.
Rev. REPAR r. of type. Legionary in middle of flan. [Plate xxxvii, 26].
7322. *Obv.* Broad, wedge-shaped, draped bust, r.
Rev. Ɱ (or ? ϣ) H T on l. Horseman in mid field, with extended arms which look as if feathered. [Plate xxxvii, 27].
7323. *Obv.* —TVS OVG.
7324. *Rev.* r. ATO.
7325. *Obv.* Long head with high forehead.
Rev. AVAIHC r. of type. Legionary in mid field. [Plate xxxvii, 28].
7326. *Obv.* SA—PV.
7327. *Obv.* D N CON. . . *Rev.* ? retrograde legend.
7328. Very barbarous, scarcely more than minim, *obv.* type with thick lips. [Plate xxxvii, 29].
7329. Very thick flan.
- 7330-414. Minims. 1*. 1 PLG, 2 TR. These include:
- (a) *Obv.* D N CON . .
 - (b) *Obv.* COI . . .
 - (c) *Obv.* NT l. of head: *rev.* [? C]PLG.
 - (d) *Obv.* DN . . : *rev.* Horse and rider only, TR.
 - (e) *Obv.* ? DOMIN r. of head.
 - (f) *Obv.* DINO (? for Domino).

7415. *Rev.* Legionary on l. facing r. SLCC, the L not certain.
Small 3 Æ. [Plate xxxvii, 30].

7416. *Obv.* CON . . : *rev.* legionary on l. facing r. minim.

*7417. Emperor on vessel: Victory at helm. 3 Æ.

*7418. (= I 856-7). $\overline{\text{TRS}}$. 3 Æ small.

7419-552. (= I 859-86). VICTORIAE DD AVGG Q NN.

3 Æ (6). I $\overline{\text{TRP}}$, I $\overline{\text{M}}$. 2*.

3 Æ small (96). I $\overline{\text{SMAL}}$ ^{*}, I $\overline{\text{SARL}}$ ^{NE}, I $\overline{\text{ARL}}$ ^M, I $\overline{\text{ARLQ}}$,
I $\overline{\text{ARL}}$, 3 $\overline{\text{PLG}}$, 2 $\overline{\text{LG}}$, I $\overline{\text{TRP}}$ ^D, I $\overline{\text{TRP}}$ ^M, I $\overline{\text{TRP}}$ ^ϕ, I $\overline{\text{TRP}}$ [☿].
2 $\overline{\text{TRP}}$, I $\overline{\text{TRS}}$ ^M, I $\overline{\text{TR}}$ [☿], I $\overline{\text{TR}}$ ^{*}, I $\overline{\text{TR}}$, 2 $\overline{\text{M}}$, I $\overline{\text{palm}}$.
13*.

3 Æ Q (30), I $\overline{\text{TRP}}$, I $\overline{\text{M}}$. 3*.
Minim (1).

7553. *Obv.* Diademed and draped bust, r., overstruck crosswise
on *rev.* of preceding type, of which is visible
VICTOR . . . and $\overline{\text{TR}}$. Initial DIN of legend of
overstrike.

Rev. Bust of original coin, r., with final AVG of legend
visible.

7554-5. (= I 851-2).

House of Constantine

Uncertain Attribution

7556-9. *Rev.* As I 556. Two $\overline{\text{PTR}}$.

7560-679. *Rev.* GLORIA EXERCITVS. Two standards. 15*.

I $\overline{\text{CONST}}$ ^{palm}, I $\overline{\text{CONST}}$, I $\overline{\text{CON}}$, I $\overline{\text{LVG}}$,
I $\overline{\text{ATC}}$, I $\overline{\text{PLG}}$, I $\overline{\text{PLG}}$, I $\overline{\text{LG}}$, I $\overline{\text{TRP}}$, I $\overline{\text{TRP}}$ [✕],
3 $\overline{\text{TRP}}$, 4 $\overline{\text{TRS}}$, I $\overline{\text{TRS}}$, I $\overline{\text{TRS}}$, I $\overline{\text{TR}}$, 2 $\overline{\text{TR}}$,
2 $\overline{\text{Q}}$, and four others of Trèves.

The coins range from 3 Æ down to 3 Æ Q and include the following :

(a) *Obv.* [D] N CONTANTINVS I . S . Laureate and mailed bust, r.

Rev. Visible part of legend normal.

(b) *Obv.* C]ONSTANTIN left of head in rather large letters.

(c) *Obv.* . . . TA . l. of small head. 3 Æ Q.

(d) *Obv.* ? CON NOB C retrograde : bust, diademed and mailed, l.

Rev. [GLORIA EXERC]ITVS, 099C.

(e) *Obv.* CONSTANTINOINI. Helmeted and mailed bust, l.

Rev. GLORIA [EXERCITVS], TRP.

7680-8028. *Rev.* GLORIA EXERCITVS. One standard.

3 Æ small (237). 1 SCONST, 2 —CONST, 1 PCON, 4 —CON, 2 —PLG, 1 PLG, 4 SLG, 2 others Lyon ; 2 PTR, 6 TRP, 1 $\frac{C}{—RP}$, 1 $\frac{M}{TRS}$, 9 TRS, 1 TR•S, 1 TRS•,

7 TR—, 1 *T, and six others Trèves. 10*.

3 Æ Q (78), 1 PLG, 1 ? TRP, and the following :

(a) *Obv.* CONTA . . .

(b) *Rev.* ?—ITI and PLG.

(c) *Obv.* r. of head SIV□—, *rev.* above standard XH□X.

(d) *Obv.* CON2LVIIII retrograde with base of letters outwards. Diademed and draped bust, r.

Rev. III . . r. of type, and *ΓVC. [Plate xxxvii, 31].

(e) *Obv.* IIIIIIIITSMOIIIVII9. Bust, l.

Rev. ?V79.

(f) (g) * on standard, and crossbar half-way up pole. [Plate xxxvii, 32].

Minims (34). 1 PLG, 1 RP, 2 TRP. 2*.

They include :

(h) *Obv.* . . . ANTVS N G.

(i) CONS l. of head.

(j) *Obv.* Diademed head, l.

Rev. ITN, ? retrograde above type.

(k) Similar.

(l) Bust r. with waved hair.

- 8029-30. *Rev.* PROVIDENTIAE AVGG. Camp gate crowned by two towers. A star above. Type of Constantine I, Cohen 454 ff. 1 —TRP.
8031. *Obv.* Legend blundered.
Rev. PROVIDENTIAE CAESS. Gate of camp. CON^s.
- *8032. *Obv.* CONST. . . . Bust, laureate and draped, l.
Rev. . . . IIT . . . Securitas standing facing with olive branch in r. hand and transverse sceptre in l. (Type borrowed from Helena?). 3 Æ Q.
Hybrid. Barbarous.
- 8033-77. *Rev.* SPES REIPVBLICE. Type = I 777-9.
I CON, I LVG, I R*~~T~~, I SMRE. Fourteen 3 Æ Q.
- 8078-101. *Rev.* Victories supporting inscribed votive shield, on which three have VOT V MVLX legible. One PLG. One with a heavy jowled bust, r., and VOT V MVLX on shield is perhaps a barbarous Magnentius, Cohen 69. Ten 3 Æ Q.
8102. Similar, but *Obv.* Diademed head, r., back off flan.
Rev. Heads of Victories off flan. Below shield ✕. TI∩.
[Plate xxxvii, 33].
- 8103-9. Victories supporting shield on column or altar.
8110. *Rev.* [VIRTVS] AVGVSTI. Emperor standing to front in military dress, looking r., holding reversed spear and resting hand on rim of shield. Type of Constantine I, Cohen 677.
8111. *Rev.* VOT XV MVLX XX in wreath.
- 8112-14. *Rev.* VOT XX MVLX XXX in wreath.
- Unclassified*
- 8115-61. 3 Æ to 3 Æ Q. 8*.
8162. Thick flan: *Obv.* apparently two lines crossing with marks in angles.
Rev. ? Victory. [Plate xxxvii, 34].
8163. 3 Æ Q, very barbarous with *rev.* WII in very large letters, or IIM retrograde.
8164. Minim. *Obv.* STAN . .
Rev. . . IN . .

206 REPORTS OF THE SOCIETY OF ANTIQUARIES

8165. Minim. *Obv.* CONSTA. Diademed bust, r. (back of head only).

Rev. HSAṬ.

8166-7. Brockage. Axis of both impressions the same, at least in one.

Magnentius (A.D. 350-3)

8168-9. *Obv.* IM CAE MAGNENTIVS AVG. Bust, bare-headed and draped, r.

Rev. FELICITAS REIPVBLICE. Magnentius standing l. in military dress, holding globe surmounted by Victory and labarum.

One $\frac{|A}{TRP\curvearrowright}$.

Cohen 5.

8170-3. *Obv.* D N MAGNENTIVS AVG. Similar.

Rev. Similar. One $\frac{|A}{TRP}$. Æ 2.

Cohen 6.

8174-5. (= I 1022). But bust, diademed and draped, r., and ✠ on standard. \overline{RPLG} , $\overline{P\cdot PL[G]}$. Æ 2.

Cohen 7.

8176. (= I 1022).

8177. (= I 1023). ? $\overline{[A]MI}$.

*8178. *Obv.* DN MAGNENTIVS P F AVG. Bust, bare-headed and draped, r.

Rev. SALVS DD NN AVG ET CAES. Monogram of Christ between A and ω in a laurel wreath. \overline{TRP} .

Cohen 29.

8179-80. Similar, without wreath. 1 Æ. One \overline{AMB} .

Cohen 30.

8181-5. Similar. 2 Æ.

Cohen 31.

8186. Similar. 3 Æ.

Cohen 32.

8187. *Obv.* Similar.

8188. *Obv.* ?[D N MAGNENTIVS C]. Same bust.
Rev. ?[VICTOR DD NN ETC]. Two Victories holding
wreath in which VOT V MVL T X. SLG.
Cp. Cohen 42.
- 8189-200. (= I 1026-9). I AMB∞, I AMB, I ANB, I TR—,
I •TRS•, I* has BV.
- 8201-17. (= I 1030). 2 AMB, I PLG, I P•PLG, I •RPLG
(3 Æ Q), I VL
SLG (3 Æ Q barb.), I N[? S]LG.
One has *obv.* SNVI r. of head.
8218. Similar, but *obv.* legend blundered, and *rev.* an emperor's
name, ?Constantine. VOT V MVL X in wreath.
8219. *Obv.* . . . TIVS D (or P) at end, leaving no room for
further letters. Bare-headed bust, r.
Rev. . . . DD NN AV . . . Victories supporting wreath on
which VOT MVL X.
- 8220-5. (= I 1031). One *obv.* . . . MNGN . . ., one A behind
head, one AM, two barbarous with blundered
legends, of which one is 3 Æ Q.
8226. *Obv.* Bare-headed bust r. DNNI—N ∞ ΛVC.
Rev. Victories resting wreath on short pillar. Above,
IIIOO ; in wreath ^oI•II. [Plate xxxvii, 35].
8227. As I 1033, but *obv.* . . . MMAG.
8228. Unassigned.
- Decentius* (Caesar A.D. 351-3)
- 8229-30. As I 1033, but no cippus below wreath. 2 Æ.
Cohen 33.
- 8231-2. (= I 1033), one RSLG, one (3 Æ Q) —TR.
8233. Similar, but bust cuirassed and *rev.* VICTORIAE DD NN
AVG ET C.
8234. Types of Magnentius I 1026-9, RSLG.
8235. Barbarous 3 Æ Q imitation of Magnentius.
Cohen 32 (✱ *rev.*).

? *Constantius Gallus* (Caesar A.D. 351-4).

8236. *Obv.* D N CONSTANTI[VS NOB C]. Apparently bare-headed bust, r. A behind head.

Rev. FEL TEMP REPARATIO. Legionary spearing horseman. Æ 2. TRP.

8237. *Obv.* . . . CONSTANTI . . . l. of head.

Rev. Victories holding wreath between them. TR. 3 Æ Q.
Cp. Cohen 37.

Julian (Caesar 355 A.D., Augustus A.D. 361-3)

8238. *Obv.* . . . NVS PF AV. Bust, bare-headed and draped, r.

Rev. FEL TEMP REPARATIO. Legionary spearing horseman. TRP.

Cp. Cohen 9 foll.

8239. *Obv.* D N CL IVLIANVS N C. Bust, bare-headed and cuirassed, r.

Rev. Similar.

Cohen 18.

8240. *Obv.* D N CL IVLIANVS NOB CAES. Bust, bare-headed and draped, r.

Rev. Similar. SMTR.

Cohen 19.

8241. *Obv.* Head of Julian overstruck obliquely on PAX PVBLICA reverse of Helena: l. of head and belonging to it D N IVL, r. of Pax • • BLICA, and below her CONST.

Rev. Legionary and horseman reverse struck over obverse of Helena, but only the horseman appears, the r. of the field being occupied by the front of Helena's head and the legend . . . LENAЕ AVG. Three hardly decipherable letters, apparently FIL, above rider of horse are probably FEL copied unskilfully in the wrong place. Dotted border l. of head and one dot over it belong to the overstrike.

8242. *Obv.* D N CL IVLIANVS NOB CAES. Bust, bare-headed and draped, r.

Rev. As I 1042-6.

Cohen 45.

8243-6. Similar, but details obscure, Cohen 42-4. Two 3 Æ Q.

- *8247. *Obv.* . . . IANVS P F AVG. Bearded bust, diademed, draped, and cuirassed, r.
Rev. Similar. $\overline{\text{PLG}}$.
8248. Victory reverse. Obscure.
- *8249. *Obv.* . . . IVL . . . Bust, r.
Rev. VOT V MVLV in wreath.
 Æ. Cp. Cohen 139-42.
- 8250-1. (= I 1041).
8252. *Obv.* Same legend. Bust, cuirassed, with diademed helmet, l., holding spear and shield.
Rev. As I 1041.
 Cohen 151.
8253. *Obv.* D N CL IVL . . . Diademed and draped bust, r.
Rev. VOTIS V MVLTV X in wreath. Siliqua.
 Cohen 158 foll.
8254. Unclassified.
Helena (wife of Julian)
8255. *Obv.* ISIS FARIA. Diademed bust of Helena, r., with lotus-flower on head.
Rev. VOTA PVBLICA. Isis standing r., on ship, looking l. and holding veil in both hands.
 Details as given uncertain. ?Cohen 20.
- Jovian* (A. D. 363-4)
8256. (= I 1047).
8257. Similar, but 3 Æ. $\overline{\text{A SIRM}}$.
 Cohen 35.
8258. Unclassified.
Carausius II
8259. The following coin is placed here on account of the derivation of its types from those of the Constantine family and Magnentius.
Obv. Bare-headed, draped bust, r. The flan rather smaller than the die, so that the back of the head and the left half of the legend do not appear. The right half of the legend is apparently the end of the name *Carausius*.
Rev. Legionary spearing horseman. Only left half of legend on flan CONTATI.

Æ 3, wt. 26½ grains. Sir Arthur Evans's coin of the same Emperor weighs 42¼ grains.

The two coins are discussed and figured in *Antiq. Journ.*, July 1926, pp. 312-13. A coin from the same *obv.* die as the new Richborough piece is in the possession of the Rev. E. A. Sydenham. The *obverse* is overstruck on a GLORIA EXERCITVS reverse with soldiers guarding one standard (large banner), the left hand soldier and the banner of the standard being visible obliquely across the bust. The *reverse* is a legionary spearing a horseman overstruck on an obverse of Constantine II, the front of whose face is visible and the legend . . . NVS IVN N C. The coin is figured by Mr. Sydenham's courteous permission. [Plate xxxvi, 1.]

Valentinian I (A. D. 364-75)

8260-352. (= I 1048-63). *Rev.* GLORIA ROMANORVM. 6*.

$\overline{\text{SMAQP}}$ (2), $\overline{\bullet\text{SMAQP}}$ (2), $\overline{\text{SMAQS}}$ (1), $\frac{\text{R}}{\overline{\text{SMAQ}}}$ (1), $\overline{\text{SMAQ}}$ (1).

$\overline{\text{PCON}}$ (3), $\frac{\text{OF|I}}{\overline{\text{CON*}}}$ (1), $\frac{\text{OF|I}}{\overline{\text{CON}}}$ (1), $\overline{\text{SCON}}$ (2),

$\frac{\text{OF|II}}{\overline{\text{CONST}}}$ (1), $\overline{\text{TCON}}$ (2), $\frac{\text{OF|III}}{\overline{\text{CONST}}}$ (2), $\overline{\text{CON}}$ (2),

$\overline{\text{CON}}^{\smile}$ (1), $\overline{\text{CON}}^{\text{III}}$ (1), $\overline{\text{CONST}}$ (1).

$\frac{\text{OF|I}}{\overline{\text{LVG}}}$ (1), $\frac{\text{OF|II}}{\overline{\text{LVGP}}}$ (1), $\frac{\text{OF|II}}{\overline{\text{LVGP}}}$ (1), $\frac{\text{OF|II}}{\overline{\text{LVGSP}}}$ (1),

$\frac{\text{OF|II}}{\overline{\text{LVGSD}}}$ (1), $\frac{\text{OF|II}}{\overline{\text{LVGS}}}$ (1), $\frac{\text{OF|II}}{\overline{\text{LVG}\bullet\text{S}}}$ (1), $\frac{\text{OF|II}}{\overline{\text{LVG}}}$ (1),

$\frac{\text{OF|II}}{\overline{\text{LVGS}}}$ (1), $\frac{\text{OF|II}}{\overline{\text{LVGS}}}$ (2), $\frac{\text{OF|II}}{\overline{\text{LVGS}[?A]}}$ (1), $\frac{\text{OF|II}}{\overline{\text{LVGS}\bullet}}$ (1),

$\frac{\text{OF|II}}{\overline{\text{LVG}}}$ (1), $\frac{\text{OF|II}}{\overline{\text{RS}}}$ (1), $\frac{\text{OF|II}}{\overline{\text{C}}}$ (1), $\frac{\text{OF|II}}{\overline{\text{PLVG}}}$ (1),

$\overline{\text{LVG}}$ (1).

$\overline{\text{SM}\Phi\text{RP}}$ (1).

$\frac{H|}{ASISC}$ (1), $\frac{FR}{BSISCS}$ (1), $\frac{FA}{BSISC}$ (1), \overline{BSISC} (1),
 $\frac{R}{SISCT}$ (1), $\frac{FA}{R}$ (1), $\frac{Q|}{SISCV}$ (1).
 $\overline{TRS fulmen}$ (1), \overline{TRS} (1).
 $\overline{OF|II}$ (4), $\overline{OF| \cdot}$ (1), $\overline{OF|II}$ * (1), $\overline{OF|II}$ \neq (1), $\overline{OF|II}$ (1),
 $\overline{OF|}$ (1).

8353-447. (=I 1064-87). *Rev.* SECVRITAS REIPVBLICAE.
2*.

$\frac{*|}{SMAQS}$ (1), \overline{SMAQS} (2), \overline{SMAQ} — (3).
 \overline{PCON} (11), $\frac{OF|I}{CON}$ (4), $\frac{OF|I}{CONSP}$ (1), $\frac{\cdot|}{PCON}$ (2),
 $\frac{\cdot|}{CON}$ (1), $\frac{N|}{SCON}$ (1), \overline{SCON} (3), \overline{TCON} (1),
 $\frac{OF|III}{CON}$ (4), $\frac{OF|III}{CONS[T]}$ (2), \overline{CON} (4), $\frac{Y|A}{CON}$ (1).
 \overline{LVGP} (1), $\frac{OF|I}{LVGP}$ (1).
 $\overline{SM\Phi RB}$ (1), \overline{RPRIMA} (3), $\overline{RSECVNDA}$ (1),
 $\overline{RTERTIA}$ (2), $\overline{RQVARTA}$ (2).
 $\frac{R}{R}$ (1), $\frac{R}{R|F}$ (2), \overline{FSISC} — (1), $\frac{R}{R|F}$
(1), $\frac{R|F}{\cdot SISC\Sigma}$ (1), $\frac{G|F}{\cdot SISC}$ (1), $\frac{RF}{R}$ — (2),
 \overline{SISC} — (2).
 $\frac{D|}{TRP}$ (1), ? \overline{TR} — (1).
 $\overline{OF|II}$ (5), $\overline{OF|}$ (1).

212 REPORTS OF THE SOCIETY OF ANTIQUARIES

8448-50. *Obv.* [D N VALENTINIANVS P F AVG]. Bust, diademed and draped, r.

Rev. [VRBS ROMA]. Roma, seated l., holding Victory on globe, and sceptre.

Cohen 81, but clipped of legends and mint marks.

8451. *Obv.* ALENTIN. Only back of head on flan. Minim, perhaps imitating I 1048.

Valens (A.D. 364-78)

*8452. *Obv.* D N VALENS P F AVG. Bust, diademed and draped, r.

Rev. GLORIA ROMANORVM. Victory advancing l. with wreath and palm branch. TRS? 3 Æ, small.

Cohen 4.

8453-97. (= I 1088-95). Cohen 11. 5*.

$\overline{\text{SMAQP}}$ (1), $\overline{\text{SMAQP}}$ (1), $\overline{\text{SMAQ—}}$ (2).

$\overline{\text{ANT}}$ (1) small module.

$\overline{\text{PCON}}$ (1), $\frac{\text{OF|I}}{\text{CON}}$ (1), $\frac{\text{E|G}}{\text{PCON}}$ (2), $\overline{\text{PCONST}}$ (1),

$\frac{\text{OF|II}}{\text{CON}}$ (1), $\overline{\text{SCON}}$ (1), $\frac{\text{OF|II}}{\text{CON—}}$ (1), $\overline{\text{—CON}}$ (3),

$\overline{\text{OF|III}}$ (2).

$\frac{\text{OF|I}}{\text{LVG}\cdot\text{S}}$ (1), $\frac{\text{O|}}{\text{LVG}\cdot\text{S}}$ (1).

$\overline{\text{RQVARTA}}$ (1), $\overline{\text{SM*RP}}$ (1).

$\overline{\text{OF|I}}$ (1), $\overline{\text{OF|II}}$ (1).

One ? overstruck on a coin of the Trèves mint $\frac{\text{OF|III}}{[\text{TRS}]}$.

8498-9. *Obv.* Similar.

Rev. RESTITVTOR REIP. Valens, in military dress, stands to front, looking r., holding a standard and a Victory on a globe.

$\overline{\text{LVG—}}$ (1), $\overline{\text{SMRP}}$ (1).

Cohen 29.

8500-671. (= I 1096-1134). 17*.

$\overline{\text{SMAQP}}$ (6), $\frac{*|}{\text{SMAQS}}$ (1), $\overline{\text{SMAQS}}$ (5), $\overline{\text{SMAQS}}$ (1),
 $\overline{\text{SMAQ—}}$ (2).

$\overline{\text{PCON}}$ (12), $\overline{\text{PCONS}}$ (1), $\overline{\text{N|PCON}}$ (1), $\overline{\text{•|PCON}}$ (1),
 $\overline{\text{OF|I}}$ (2), $\overline{\text{OF|I}}$ (1), $\overline{\text{OF|I}}$ (3), $\overline{\text{S|I}}$ (1), $\overline{\text{OF|I}}$
(1), $\overline{\text{SCON}}$ (6), $\overline{\text{OF|II}}$ (2), $\overline{\text{TCON}}$ (3), $\overline{\text{FCON}}$ (1),
 $\overline{\text{OF|III}}$ (1), $\overline{\text{OF|III}}$ (1), $\overline{\text{OF|Γ}}$ (1), $\overline{\text{C|CON}}$ (1),
 $\overline{\text{OF|CON}}$ (1), $\overline{\text{CON}}$ (6), $\overline{\text{CON}}$ (8), $\overline{\text{CONST}}$ (1).
 $\overline{\text{OF|I}}$ (10), $\overline{\text{OF|I}}$ (1), $\overline{\text{OF|I}}$ (2), $\overline{\text{OF|I}}$ (2),
 $\overline{\text{S|LVGP}}$ (1), $\overline{\text{S|LVGP}}$ (1), $\overline{\text{C|LVGP}}$ (1), $\overline{\text{OF|I}}$ (1), $\overline{\text{LVGP}}$
(3), $\overline{\text{PLVG}}$ (2), $\overline{\text{OF|I}}$ (1), $\overline{\text{OF|II}}$ (1), $\overline{\text{OF|II}}$ (1),
 $\overline{\text{OF|LVG}}$ (1), $\overline{\text{LVG}}$ (2).
 $\overline{\text{SMN}}$ (1).
 $\overline{\text{SMΦRP}}$ (2), $\overline{\text{SMΦRA}}$ (1), $\overline{\text{SMΦRB}}$ (1), $\overline{\text{SMΦRT}}$ (1),
 $\overline{\text{SMΦRQ}}$ (1), $\overline{\text{SMΦR}}$ (2).
 $\overline{\text{RPRIMA}}$ (2), $\overline{\text{RTERTIA}}$ (3), $\overline{\text{RQVARTA}}$ (1).
 $\overline{\text{R|F}}$ (1), $\overline{\text{R|F}}$ (1), $\overline{\text{R|F}}$ (1), $\overline{\text{P|F}}$
 $\overline{\text{ASISCP}}$ (1), $\overline{\text{RSISC}}$ (1), $\overline{\text{SISCV}}$ (1), $\overline{\text{SISCVE}}$
(1), $\overline{\text{R|F}}$ (1), $\overline{\text{ASISCVE}}$ (1).
 $\overline{\text{TRP}}$ (1), $\overline{\text{?TRP}}$ (1), $\overline{\text{TRSX}}$ (1), $\overline{\text{TRS}}$ (1).
 $\overline{\text{OF|I}}$ (7), $\overline{\text{OF|II}}$ (2), $\overline{\text{*|I}}$ (1), $\overline{\text{A|I}}$ (1).

8672. *Obv.* ? Similar.

Rev. [? VICTORIA AVGGG]. Victory advancing l. with wreath and palm.

? Cohen 56, but very worn.

8673. *Obv.* Similar.

Rev. VOT X MVLTV in wreath. $\overline{\text{TRP}}$. Silique.

8674. *Obv.* Similar.

Rev. VRBS ROMA. Rome seated l., holding Victory on a globe, and a sceptre. $\overline{\text{TRPS}}$. $\overline{\text{AR}}$.

Cohen 109.

8675-6. Unclassified.

Gratian (A. D. 367-83)

8677. *Obv.* D N GRATIANVS P F AVG. Bust, diademed and draped, r.

Rev. CONCORDIA AVGGG. Rome seated to front, looking l., holding globe and reversed spear. 3 $\overline{\text{AE}}$.

Cohen 3.

8678. *Obv.* Similar.

Rev. FEL TEMP REPARATIO. Gratian, in military dress and diademed, standing l., raising a kneeling woman and holding a globe surmounted by a Victory. 2 $\overline{\text{AE}}$. $\overline{\text{SCON}}$.

Cohen 9.

8679. *Obv.* Similar.

Rev. FELICITAS ROMANORVM. Victory advancing l. and holding wreath and palm. $\overline{\text{SMAQP}}$.

Cohen 11.

8680-748. (= I 1135-46). 3*.

$\overline{\text{PCON}}$ (2), $\overline{\text{SCON}}$ (3), $\frac{\text{N}|}{\text{SCON}}$ (1), $\frac{\text{OF}|II}{\text{CON}}$ (1), $\overline{\text{TCON}}$

(15), $\overline{\text{TCON}}$ (1), $\frac{\text{N}|}{\text{TCON}}$ (2), $\frac{\text{N}|}{\text{CON}}$ (1), $\frac{\text{OF}|III}{\text{CON}}$ (2),

$\overline{\text{OF}|III}$ (2), $\overline{\text{CON}}$ (6).

8749-50. Two minims.

*8751. *Obv.* D N GRATIANVS P F AVG. Bust, diademed and draped, r.

Rev. Similar. $\frac{\text{OF}|III}{\text{CON}}$. 3 $\overline{\text{AE}}$.

Not in Cohen.

8752-72. (= I 1147-55). Cohen 23 (not 16).

$\overline{\text{TCON}}$ (I), $\overline{\text{CON}}$ (I).

$\frac{\text{OF|II}}{\text{LVGP}}$ apparently (I), $\frac{\text{OF|II}}{\text{LVGS}}$ (I), $\frac{\text{OF|II}}{\text{LVG}}$ (I),

$\frac{\text{R|S}}{\text{LVGS}}$ (I), $\overline{\text{LVGS}}$ (I), $\overline{\text{RPRIMA}}$ (I), $\overline{\text{C|?R}}$ (I),

$\frac{\text{OF|II}}{\text{LVGS}}$ (I).

8773-5. (= I 1156).

$\frac{\text{OF|II}}{\text{LVGS}}$ (I), $\frac{\text{O F II}}{\text{LVGS}}$ (I), $\frac{\text{S}}{\text{LVGS}}$ (I), $\frac{\text{P|S}}{\text{LVGS}}$ (I).

*8776. (= I 1147 or 1156). $\overline{\text{PCON}}$.

8777-84. (I 1157).

$\frac{\text{S}}{\text{LVGP}}$ (I), $\overline{\text{LVGP}}$ (I), $\overline{\text{LVGS}}$ (I), $\overline{\text{SMTRP}}$ (2).

8785-812. (= I 1158-64). 3*.

$\overline{\text{SMAQP}}$ (I), $\overline{\text{SMAQS}}$ (I).

$\frac{\text{V|I}}{\text{PCON}}$ (I), $\overline{\text{PCON}}$ (I), $\frac{\text{V|N}}{\text{SCON}}$ (I), $\overline{\text{SCON}}$ (4),

$\overline{\text{TCON}}$ (I), $\overline{\text{CON}}$ (I).

$\frac{\text{OF|I}}{\text{LVGP}}$ (2), $\frac{\text{OF|I}*}{\text{LVGP}}$ (I), $\frac{\text{OF|I}}{\text{LVG}}$ (I), $\overline{\text{LVG}}$ (I).

$\overline{\text{SMΦRT}}$ (I), $\overline{\text{SMΦRQ}}$ (I).

$\frac{\text{OF|I}}{\text{S}}$ (I), $\frac{\text{OF|I}}{\text{S}}$ (I), $\frac{\text{OF|I}}{\text{S}}$ (I).

8813-15. *Obv.* D N GRATIANVS AVGG AVG.

Rev. Similar.

$\frac{\text{OF|I}}{\text{LVGP}}$ (I), $\frac{\text{O R}}{\text{LVGP}}$ (I), $\frac{\text{OF|I}}{\text{LVGP}}$ (I), $\overline{\text{LVGP}}$ (I).

8816-17. *Obv.* [D N GRATIANVS P F AVG]. Same bust.

Rev. VIRTVS ROMANORVM. Rome seated on cuirass, looking l., holding globe and reversed spear. One 3 Æ Q. Cp. Cohen 57.

8818-21. *Obv.* Similar.

Rev. VOT X MVLT XX in laurel wreath. $\overline{\text{LVG}}$ (I).
Cohen 71.

216 REPORTS OF THE SOCIETY OF ANTIQUARIES

8822-53. (=I 1165-71).

$\overline{\text{PCON}}$ (5), $\overline{\text{TCON}}$ (1), $\overline{\text{LVGP}}$ (5), $\overline{\text{LVG—}}$ (2),
 $\overline{\text{LVG}}$ (2).

8854-61. *Obv.* Similar.*Rev.* VOT XX MVL T XXX in wreath. $\overline{\text{SMNB}}$ (1).

Cohen 77.

8862-6. *Rev.* VOT— MVL T—.

8867-9. Unclassified.

*House of Valentinian I.*8870-968. (=I 1172-91). Many of small 3 Æ module.
Eight 3 Æ Q. 2*.

$\overline{\text{PLG}}$ (1), $\overline{\text{LVGP}}$ (1), $\overline{\text{OF|I}}$ (2), $\overline{\text{OF|II}}$ (1), $\overline{\text{OF|II}}$ (3),

$\overline{\text{OF|II}}$
 $\overline{\text{LVG}}$ (1), $\overline{\text{OF|II}}$
 $\overline{\text{LVGS}}$ (1), $\overline{\text{OF|II}}$
 $\overline{\text{E}}$ (1), $\overline{\text{OF|II}}$ (1), $\overline{\text{—TR}}$ (1).

One small 3 Æ bust has a very thin neck.

8969. Similar, but barbarous, and legends on both sides ending
○○○○. 3 Æ Q.8970. Similar, but ? *rev.* type facing l. 3 Æ Q.8971-2. Similar types to I 1172, but one with blundered legends,
the other *obv.* NO and *rev.* type much off flan.
Minims.8973-9154. (=I 1192-1217). Many small 3 Æ, some 3 Æ Q.
13*.

$\overline{\text{ALE}}$ (1), $\overline{\text{ALEB}}$ (1), $\overline{\text{PCON}}$ (3), $\overline{\text{SCON}}$ (2), $\overline{\text{OF|II}}$
 $\overline{\text{CON}}$ (1),

$\overline{\text{TCON}}$ (1), $\overline{\text{CON}}$ (6), $\overline{\text{OF|}}$
 $\overline{\text{CON}}$ (1), $\overline{\text{OF|III}}$ (1), $\overline{\text{OF|I}}$
 $\overline{\text{LVGP}}$.

(1), $\overline{\text{OF|I}}$ (1), $\overline{\text{OF|—}}$ (1), $\overline{\text{O|I}}$ (1), $\overline{\text{PLVG}}$ (1),

$\overline{\text{LVG—}}$ (1), $\overline{\text{OF|I}}$ (1), $\overline{\text{OF|II}}$ (1), $\overline{\text{SMΦRP}}$ (1),

$\overline{\text{—SIS}}$ (1), $\overline{\text{TRP}}$.

One 3 Æ Q is barbarous with *rev.* C| and blundered legend.

9155-8. *Rev.* [VRBS ROMA]. Rome seated l. on cuirass, holding Victory on globe in r. hand and reversed spear in l. Æ siliquae. All clipped.
Cp. Gratian, Cohen 86. 3*.

*9159-60. *Rev.* VOT XV MVLT XX in wreath.
LVGS (1), SMRT (1). 3 Æ Q.

9161-6. Unclassified.

3 Æ from late third century to c. A. D. 383

9167-514. Unassigned to emperors.

House of Theodosius I

Valentinian II (A. D. 375-92)

9515. *Obv.* D N VALENTINIANVS P F AVG. Bust, diademed and draped, r.

Rev. GLORIA REIPUBLICAE. Camp gate crowned by two towers.

Cohen 12. 3 Æ Q.

9516. *Obv.* D N VALENTINIANVS IVN P F AVG. Similar bust.

Rev. REPARATIO REIPVB. Valentinian, in military dress, standing l., holding a Victory, and raising a turreted woman from her knees. 2 Æ.

Cohen 26.

9517-748. *Rev.* SALVS REIPUBLICAE. Victory dragging captive, l. = I 1299-1325, but Cohen 30. 15*.

—AQP (12), —AQS (10), —AQ— (4), —SMAQ— (? 1).

—CONSP (3), —CONSB (1), —CON— (1).

—RP (8), —R•P (4), —Ṛ•P̣ (1), —Ṛ•P̣ (2), —RS (1),

—R•— (1), —R— (5), —R (1).

—TESA (1).

—TR (1).

9749. *Uncertain.* ? 'Spes Reipublicae' type of soldier, l., dragging kneeling captive.

Cp. Cohen 34. 3 Æ Q.

218 REPORTS OF THE SOCIETY OF ANTIQUARIES

9750. *Obv.* D N VALENTINIANVS IVN P F AVG. Bust, diademed and draped, r.

Rev. VICTORIA AVGGG. Victory advancing l. with wreath and palm. Clipped.

Æ (*siliqua*). The letters NP in monogram.

Cohen 40.

9751-10039. Similar, but NP not in monogram, and 3 Æ Q. (= I 1725-89). 21*.

† ANT (1). †

† AQP (2). †

PCON (68), SCON (5), TCON (4), —CON (16).

PLVG (1), LVGP (16), LVGS (2), LVG∩ (1),

LVG— (10).

† —SIS (1). †

† TRS (1), TR— (1) † (? reduced 'Securitas' types of Valentinian I).

10040-55. *Rev.* Two Victories facing. (= I 2418-23). 2*.

SMAQP (2), SMAQ— (2), LVG• (1), RT (1), $\frac{\cdot}{\text{RP}}$ (1),

$\frac{\cdot}{\text{—}}$ (1).

*10056. *Obv.* Similar.

Rev. VOT V MVLT X in laurel wreath.

SMAQP. 3 Æ Q.

Cohen 68.

10057-62. *Rev.* VOT X MVLT XX in wreath. 3 Æ Q.

CONS— (1), ? SMT— (1).

Cohen 73.

10063-4. *Rev.* VOT XV MVLT XX. (= I 2452-3, or Cohen's type 74 with the longer *obv.* legend).

10065-6. *Rev.* VOT XX MVLT XXX.

Cohen 75.

10067-74. Unclassified.

Theodosius.

10075-6. *Obv.* D N THEODOSIVS P F AVG. Bust, diademed and draped, r.

Rev. CONCORDIA AVGGG. Rome seated to front, holding globe in r. hand and reversed spear in l.

3 Æ. Cohen 14. 1* uncertain.

10077. *Obv.* Similar.
Rev. GLORIA ROMANORVM. Theodosius in military dress, advancing r., looking back and dragging captive by the hair, and holding a labarum.
 3 Æ. Cohen 23.
- *10078. *Obv.* Similar.
Rev. As Valentinian II 9516.
 Cohen 27.
- 10079-313. *Rev.* SALVS REIPVBLICAE. Victory dragging captive l. (= I 1263-98). 12*.
 AQP (10), AQS (25), A*Q (1) [?R*Q],
 AQ— (9).
 CONS (1), CONSA (1).
 SMKB (1), SMKΔ (1), SMK— (2).
 R•P (2), RS (2), RT (5), R•T (4), R*T (1),
 RQ (4), R•Q (1), R*Q (1), R— (4), R*— (1).
 TR (1), but both legends doubtful.
 One rev. type ?left to right: one obv. apparently
 . . THEIODO.
- 10314-615. *Rev.* VICTORIA AVGGG. Victory advancing left.
 (= I 1651-1724). 27*.
 ?AQS (1).
 PCON (12), SCON (38), TCON (6), —CON (27).
 LVGP (16), LVGS (1), LVG— (7).
 † R•T (1), RQ (1). †
 † ASIS (1). †
 TR (9).
 One barbarous, with type half off flan, perhaps belonging here.
- *10616. *Rev.* VICTORIA AVG. Two Victories standing facing, each with wreath and palm branch.
 [T]ESB. 3 Æ Q.
 Not in Cohen.
- *10617. As I 1651, but a long bar, knobbed at the ends, passes through the wreath, apparently developed from the ends of the wreath, transitional stages sometimes occurring.

10618-55. *Rev.* VICTORIA AVGGG. Two Victories meeting one another.

(= I, 2411-15).

$\overline{\text{SMAQP}}$ (2), $\overline{\text{SMAQS}}$ (1), $\overline{\text{SMAQ}}$ — (1).

$\overset{\cdot}{\text{RP}}$ (1), $\overset{\cdot}{\text{RP}}$ (1), $\overset{\cdot}{\text{RB}}$ (1), $\overset{\cdot}{\text{RE}}$ (1), $\overset{\cdot}{\text{RE}}$ (1), $\overset{\cdot}{? \text{RT}}$ (1),

$\overset{\cdot}{\text{R}}\text{---}$ (1), $\overline{\text{R}}$ — (1), $\overset{\cdot}{\text{---}}$ (8), $\overset{\cdot}{\text{---}}$ (2). The single dot in field is quite certain in the coins given.
† $\overset{\cdot}{? \text{TRS}}$ (1). †

10656. *Rev.* VIRTVS ROMANORVM. Rome seated on cuirass, holding globe surmounted by a Victory, and a sceptre.

Cohen 57. *R.* Siliqua.

10657-60. *Rev.* VOT V MVLT X in wreath. 3 *Æ* Q.

$\overline{\text{ASIS}}$ — (1), $\overline{\text{SMT[?R]}}$ (1).

Cohen 65.

10661-76. *Rev.* VOT X MVLT XX. (= I 2442-4). 1*.

$\overline{\text{SMAQ}}$ — (1), $\overline{\text{CON}}$ (1), $\overline{\text{SMKA}}$ (2), $\overline{\text{SMKB}}$ (1),
 $\overline{\text{SMK}}$ — (1), $\overline{\text{TES}}$ (1).

10677. (= I 2451). But VOT X·V MVLT XX.

10678-81. Other votive reverses.

10682-9. Unclassified.

Alia Flaccilla (wife of Theodosius)

10690-1. *Obv.* AEL FLACCILLA AVG. Bust, diademed, r.

Rev. SALVS REIPVBLICAE. Victory seated r., writing P on a shield set on a cippus.

One $\overline{[? \text{SM}] \text{NE}}$. 3 *Æ* Q.

Cohen 5.

Magnus Maximus (A.D. 383-8)

10692-3. (= I 1218). $\overline{\text{SMTRP}}$ (1).

10694-800. *Rev.* SPES ROMANORVM. Camp gate. (= I, 1219-38). 8*.

$\overline{\text{T} \cdot \text{AQP}}$ (1), $\overline{\text{SMAQP}}$ (2), $\overline{\text{SMAQS}}$ (2), $\overline{\text{SMAQ}}$ — (2).
 $\overline{? \text{AR}}$ (1).

$\overline{\text{PCON}}$ (13), $\overline{\text{SCON}}$ (4), $\overline{\text{TCON}}$ (5), $\overline{\text{—CON}}$ (10).

$\overline{\text{LVGP}}$ (6), $\overline{\text{LVGS}}$ (2), $\overline{\text{LVG—}}$ (3).

$\overline{\text{RP}}$ (1), $\overline{\text{RT}}$ (1), $\overline{\text{R—}}$ (3).

$\overline{\text{SMTR}}$ (6), $\overline{\text{TR}}$ (1).

10801-2. *Obv.* D N MAG MAXIMVS P F AVG.

Rev. VICTORIA AVGG. Victory l. with wreath and palm.

$\overline{\text{LVGP}}$ (1), $\overline{\text{LVGS}}$ (1).

Cohen 11.

10803. *Rev.* VICTORIA AVGGG. Two Victories facing one another.

Cohen 13.

10804-5. (= I 1239) $\overline{\text{SCON}}$.

Victor (A.D. 383-8).

10806-45. *Rev.* SPES ROMANORVM. (= I 1241-51). I*.

$\overline{\text{SMAQP}}$ (3), $\overline{\text{SMAQS}}$ (2), $\overline{\text{SMAQ—}}$ (1).

$\overline{\text{PCON}}$ (6), $\overline{\text{SCON}}$ (1).

$\overline{\text{LVGP}}$ (3), $\overline{\text{LVGS}}$ (2), $\overline{\text{LVG—}}$ (1).

$\overline{\text{SMTR}}$ (2).

10846. *Obv.* D N LF [*sic*] VICTOR P F AVG.

Rev. Similar.

$\overline{\text{PCON}}$.

10847. *Obv.* D N FL VICTOR P F AVG.

Rev. VIRTVS ROMANORVM. Rome seated to front, looking l., holding globe and reversed spear.

$\overline{\text{MDPS}}$.

Cohen 6.

Magnus Maximus or *Victor*

10848-70. (= I 1252-6). $\overline{\text{SMAQ—}}$ (1), $\overline{\text{—CON}}$ (1).

Eugenius (A.D. 392-4).

10871. *Obv.* D N EVGENIVS P F AVG. Bust, diademed and draped, r.

Rev. SALVS REIPVBLICAE. Victory l., carrying trophy and dragging captive by hair.

$\overline{\text{LVGP}}$.

Cohen 3.

222 REPORTS OF THE SOCIETY OF ANTIQUARIES

- 10872-7. (= I 2487-8). $\overline{\text{AQ—}}$ (2), $\overline{\text{AQS}}$ (2), $\overline{\text{RP}}$.
- 10878-909. (= I 2489). $\overline{\text{LVGP}}$ (1), $\overline{\text{LVG—}}$ (2), $\overline{\text{TR}}$ (3). The common reading is *VICTORIA AVGGG*. On only one coin is *AVGG* probable, and on none certain.
- 10908-9. *Rev.* *SPES ROMANORVM*. Type of I 10315. $\overline{\text{AQS}}$, $\overline{\text{RP}}$.
- 10910-12. *Rev.* *VIRTVS ROMANORVM*. Rome seated l. on cuirass, holding globe surmounted by *Victory* in r. hand, and reversed spear in l. One $\overline{\text{TRPS}}$.
Cohen 14.
Arcadius (A.D. 383-408)
10913. *Obv.* *D N ARCADIVS P F AVG*. Diademed and draped bust r.
Rev. *GLORIA ROMANORVM*. Type of I 1259.
Not in Sabatier.
- 10914-11275. *Rev.* *SALVS REIPVBLICAE*. (= I 1326-55).
29*.
 $\overline{\text{ANTΓ}}$ (1).
 $\overline{\text{AQP}}$ (42), $\overline{\text{AQS}}$ (18), $\overline{\text{AQ—}}$ (8).
 $\overline{\text{CONS—}}$ (2), $\overline{\text{CONST}}$ (1).
 $\overline{\text{SMKΓ}}$ (1), $\overline{\text{SM[?N]B}}$ (1).
 $\overline{\text{RP}}$ (3), $\overline{\text{RT}}$ (1), $\overline{\text{RQ}}$ (1), $\overline{\text{RE}}$ (3), $\overline{\text{R—}}$ (1).
- 11276-2561. *Rev.* *VICTORIA AVGGG*. *Victory* advancing l. (= I 1790-1933). 77*.
 $\overline{\text{AQP}}$ (1).
 $\overline{\text{PCON}}$ (45), $\overline{\text{SCON}}$ (30), $\overline{\text{TCON}}$ (96). $\overline{\text{—CON}}$ (91).
 $\overline{\text{LVGP}}$ (81), $\overline{\text{LVG—}}$ (23), $\overline{\text{[L]V?}}$ (1).
 $\overline{\text{RP}}$ (2), $\overline{\text{•RP}}$ (1), $\overline{\text{R—}}$ (2). None of the Roman marks is quite certain.
 $\overline{\text{TRP}}$ (2), $\overline{\text{TR—}}$ (1), $\overline{\text{TR}}$ (27).
 $\overline{\text{V|}}$ (2).
- 12562-83. *Rev.* *VICTORIA AVGGG*. Two *Victories* facing one another (type of I 2411-33).
Not in Sabatier.
 $\overline{\text{RP}}$ (1), $\overline{\text{RT}}$ (1), $\overline{\text{RQ}}$ (1).
- 12584-93. (= I 2434). $\overline{\text{—LDP}}$ (1), $\overline{\text{?TRS}}$ (1), $\overline{\text{TRPS}}$ (1).

- 12594-99. (= I 2438-9). $\overline{\text{SMHA}}$ (1), $\overline{\text{SMKA}}$ (1), $\overline{\text{TR}}$ (1).
 12600. *Rev.* VOT V MVLX in wreath. Clipped siliqua.
 12601. *Rev.* VOT X MVLX XX in wreath. 3 Æ Q. $\overline{\text{ANΔ}}$.
 Sabatier 48.
 *12602. *Rev.* VRBS ROMA. Roma seated l., holding globe sur-
 mounted by Victory, and reversed spear.
 Clipped siliqua. Sabatier 25.
 12603-21. Unclassified. 3 Æ Q. 1*.

Honorius (A.D. 393-423)

- 12622-737. *Rev.* SALVS REIPVBLICAE (= I 1356-68). 7*.
 $\overline{\text{AQP}}$ (3), $\overline{\text{AQS}}$ (4), $\overline{\text{AQ—}}$ (3).
 † $\overline{\text{TCON}}$ (1), $\overline{\text{—CON}}$ (1). †
 † $\overline{\text{LVGP}}$ (1). †
 $\overline{\text{RP}}$ (2), $\overline{\text{R•P}}$ (1), $\overline{\text{R•—}}$ (1).

Ten of the above coins, one from the Roman mint, have the obverse legend D N ONORIVS P F AVG. One coin apparently begins HONORIVS . . .

12738. Minim with *obv.* [N]ORI in rather large letters, and perhaps *Salus Reipublicae* reverse.
 12739-952. *Rev.* VICTORIA AVGGG. Victory advancing l.
 (= I 1934-56). 12*.
 $\overline{\text{PCON}}$ (4), $\overline{\text{TCON}}$ (16), $\overline{\text{CON}}$ or $\overline{\text{—CON}}$ (16).
 $\overline{\text{LVGP}}$ (4), $\overline{\text{LVG—}}$ (6), $\overline{\text{—LVG}}$ (1).
 $\overline{\text{?R—}}$ (1).
 $\overline{\text{TR}}$ (3), $\overline{\text{TRP}}$ (1).

Three, one apparently of the Roman mint, read D N ONOR . . ., and one D N ONRI . . .

- 12953-8. (= I 2435). 1*.
 $\overline{\text{MDPS}}$ (2), $\overline{\text{MDP—}}$ not clipped! (1).
 One coin reads D N HONRIVS.

- 12959-66. Unclassified. 2*.

House of Theodosius (unassigned)

12967. *Rev.* CONCORDIA AVGGG. Rome seated facing, holding globe in r. hand and reversed spear in l. Type as Theodosius.
 Cohen 14. 3 Æ Q.

224 REPORTS OF THE SOCIETY OF ANTIQUARIES

*12968. *Rev.* GLORIA ROMANORVM. Emperor dragging captive with r. hand and holding labarum in l.

AQS. 3 Æ, small.

Type as Theodosius, Cohen 23.

12969-5523. *Rev.* SALVS REIPVBLICAE. (= I 1377-1650).
I 17*.

ANT (2).

AQP (36), $\frac{T|}{AQP}$ (1), AQS (16), † AQT (2) †,

AQ— (20).

† PCON (2), TCON (1), —CON (3) †, SMHA (1).

LVG— (2), —LG (1).

RP (11), R•P (7), R•B• (1), RB (2), R•S (1),
RT (4).

R T (1), R*T (1), R•T (2), RQ (3), R•Q (2),

RE (3), R— (1), R— (8), R (3), *R (1),

R*— (1).

SIS— (1).

† TRP (2), TRS (2). †

Eight are minims. A few are barbarous, one having *obv.* bust l. One of the Roman mint appears to be overstruck on a *Victoria Auggg* reverse. One reverse type is left to right. On another, which perhaps has *obv.* DNHO . . . the † of the *rev.* becomes X. One *obv.* of Roman mint has a very thin neck.

15524. Similar, but *obv.* [?D]IVODO AVG.

15525-9057. *Rev.* VICTORIA AVGGG. Victory advancing l.
(= I 1960-2410). 153*.

† AQM (1). †

PCON (37), SCON (17), TCON (45), CON or
—CON (93), various Arles officinae (63).

LVGP (61), LVG— (45), LVG— or LVGP (20),

LG— (1).

R— (1), † R— (1), R (1). †

† TRP (1) †, TR (57), TR• (1).

? — — X (1) but ? double struck.

V| (2), S| (2).

The reverse of two coins ends AVGG, one having TR, the other ? NN. The obverse of another has P F AVG. One coin has both types nearly off flan. Several are barbarous; one is of lead; eleven are minims.

19058. Similar, but *Obv.* ? VI AV retrograde across the middle of the flan.

Rev. ? Victory, but head only, and most of legend off flan. Perhaps imitated from a coin of Victorinus.

19059-267. *Rev.* VICTORIA AVGGG. Two Victories meeting. (= I 2424-33.) 7*.

LVG (1).

RP (4), RT (2), $\frac{\cdot}{R \cdot T}$ (1), RQ (1), RE (1), R— (1),

$\frac{\cdot}{R \cdot}$ (1), $\frac{\cdot}{\cdot}$ (1).

One minim.

19268. *Rev.* VIRTVS ROMANORVM. Rome seated facing, holding globe and reversed spear.

Cp. Valentinian II, Cohen 60. *R.*

19269-73. Type as I 2434. *R.* CON (1).

19274-5. Similar, but spear replaced by sceptre. *R.*

Cp. Theodosius, Cohen 57.

Voivre Reverses (the legend in wreath). *R.*

Mostly clipped.

19276. VOT X.

19277. VOT X MVL T—. *R.*

19278-9. VOT X MVL T XV. ANT (1). *R.*

19280. VOT X MVL T XX. *R.*

19281-6. VOT XV MVL T XX. SMA— (1), LVG (1).

19287-8. VOT XX MVL T XXX.

19289-300. Illegible. One a minim.

VRBS ROMA *reverses* *R.*

*19301. (= I 2462-3).

19302-6. Similar, but sceptre replaced by reversed spear.

Undetermined.

19307. Illegible siliqua.
19308. *Obv.* Two busts, the left-hand one the less obscure.
19309. Double-struck. Head on both sides.
19310. *Obv.* Bust r.
Rev. HA—VL on either side of pattern of two crosses.
[Plate xxxvii, 36.]
19311. *Obv.* Apparently bust r.
Rev. Victory l. dragging captive with l. hand and holding erect staff with vexillum in r.
Scarcely above minim size.
19312. *Obv.* Draped bust r. Wedge-shaped bust.
Rev. Barbarous horse? to l. with fork pattern in front depending from the end of a bar above his back.
3 Æ Q. [Plate xxxvii, 37.]
19313. Similar, but bust not wedge-shaped. 3 Æ. [Plate xxxvii, 38.]

Constantine III (A. D. 407—11).

19314. *Obv.* D N CONSTANTINVS P F AVG. Bust, diademed and draped, r.
Rev. VICTORIA AAVGGG. Rome seated l. holding globe surmounted by Victory and a reversed spear.
SMAR. R. Not clipped.
Near Cohen 7, but only two initial A's of AAVGGG and three G's on rev. The British Museum has one with AAVGGG as our coin, and another AAVGGGG, but the fourth G is low down in the r. field immediately under the third G and in very slight relief.

? Pavunius (new Emperor)

19315. *Obv.* D N PAVVNIVS AVG. Diademed and draped bust, r.
Rev. VICTOR[IA] AVGGG. Victory l. holding wreath and palm. 3 Æ Q.
Mint mark barbaric.
The initial P of the emperor's name seems nearly certain: the reading of the remaining letters is not, I think, in any doubt. [Plate xxxvi, 2.]

Post-Roman Coins

By G. C. BROOKE, F.S.A.

Sceattas

1. *Obv.* Radiate head to r.
Rev. Degraded standard type. \mathfrak{R} 18.9 grs.
 Cf. B. M. C. I, pl. 1, 5, but this coin is different in style. The head, which bears the usual form of radiate crown, is composed of a straight line forming the nose, below which are four pellets, arranged 2, 1, 1, forming the mouth and chin. In addition to the pellet for the eye, a cluster of three pellets on the face seems to represent the ear. Two pellets at the lower edge of the coin mark the line of the neck. Behind the head is V and in front A (?).

2. *Obv.* Bust facing, with hair shown as a network of crossed lines bound with a fillet which terminates in a long double streamer knotted at each side of the face. The face has a negroid appearance due to the oval shape of the eyes and mouth.
Rev. An arabesque pattern of the interlaced curves forming a kind of cross with a trefoil as each limb. A pellet in centre and a rosette between each pair of limbs. \mathfrak{R} 15.6 grs.
 This coin is similar to B. M. C. I, pl. IV, 18, but on the Museum specimen the features are worn away and the reverse pattern has pellets in place of the rosettes. The reverse design and the execution of the obverse figure are interesting as examples of early Anglo-Saxon work.

- 3, 4. *Obv.* Bust r. with cable border.
Rev. Bird to r., pellet in front, in plain and beaded circles.
 Similar to B. M. C. I, pl. IV, 1, but on these two specimens there is no cross in front of the bust, and a pellet takes the place of the cross on the reverse. \mathfrak{R} 18.2, 15.4 grs.

Pennies of Offa, King of Mercia 757-796

1. *Obv.* + OFF $\bar{\text{A}}$ REX in two lines divided by a beaded line across the field; a cross above and below. Pellets profusely.

Rev. + δ ∪ δ between leaves of a large quatrefoil which has a trefoil of pellets on long stem on each leaf and between each pair. Pellets profusely. *R* 21·0 grs.

The reverse of this coin is similar to that of B. M. C. I, pl. v, 7, which has a portrait obverse.

The obverse type and the style of ornament used in the reverse design mark this coin as belonging to the earlier group of Offa's coins, that is to say it was probably struck in the period between the battle of Otford (774) and the death of Archbishop Jaenberht (790). See *Num. Chron.*, 1920, pp. 57 ff.

2. *Obv.* ⬠FFÆ REX in two lunettes between which are two crosses connected by a beaded line.

Rev. EPEL N◊P in two lines divided by a beaded bar with moline ends. Cross above and below. *R* 20·5 grs.

Similar to B. M. C. I, pl. vii, 10.

This coin is, like the last, attributable to the earlier group of Offa's coins (say 774-90).

3. *Obv.* + O FFÆR EX between limbs of a cross with trefoil ends; four 'trefoil on stem' ornaments springing from centre of cross.

Rev. ◊ SM ◊ δ between limbs of a cross with a trefoil ends which has circular voiding in the centre. Pellets profusely. *R* 20·0 grs.

Similar to B. M. C. I, pl. vii, 14.

This coin again may be assigned to the approximate date 774-90.

Eadwald, King of the East Angles

Obv. REX + EÆDVÆ LD in three lines separated by beaded lines. Trefoil of pellets before and after REX, rosette before and after LD.

Rev. ·+··L· √ ·L· on leaves of quatrefoil; four rosettes in field. *R* 22·1 grs. (pl. xxxvi, 3).

Eadwald is a king unknown to history and he has been supposed, from the evidence of coins alone, to have been king of East Anglia at some time in the period 820-30.

This is the third variety of his coins at present known and it adds important evidence for the dating of this unknown king. The two varieties previously known are :

(1) Struck by the moneyer Eadnoth, of the same design as this new coin (B. M. C. I, pl. xiv, 3, and Rashleigh sale, Sotheby, 21 June 1909, lot 108).

(2) Struck by the moneyer Wihtred (sometimes misread as Regniht), of similar design to the Offa coin figured in *Num. Chron.*, 1920, pl. xii, 4.

Of the three moneyers, Eadnoth, Lul, and Wihtred, the first is known to us on coins of Aethelstan I of East Anglia (date unknown, but from his coins evidently contemporary with Beornwulf 823-5, and Wiglaf, 827-39) and of Beornwulf of Mercia. Lul and Wihtred both overlapped the reigns of Offa and Coenwulf. Lul was also the moneyer of the East Anglian Ethelberht who was put to death by order of Offa in 794. The Wihtred coin of Eadwald has a reverse identical, but for die difference, with that of Offa, whose coin like Eadwald's has been misread as Regniht. The Richborough coin of Lul has a reverse identical, but for die difference, with one of Coenwulf; this differs from the reverse of other Lul coins of Coenwulf and of Offa only in the use of rosette ornaments.

We have therefore in the Lul and Wihtred coins of Eadwald an identity of style and moneyers with a coinage which must clearly have been very late in the reign of Offa and very early in the reign of Coenwulf, and from this we may conclude that Eadwald was reigning at the end of the eighth century, perhaps a few years before 800. The connexion of the name Eadnoth with coins of Aethelstan I of East Anglia and of Beornwulf of Mercia may show an identity of moneyer, but in that case the wide difference of style requires a lapse of time between the Eadwald coin and those of Athelstan and Beornwulf. In style and type the Eadnoth coin of Eadwald is identical with the coinage which overlaps the reigns of Offa and Coenwulf.

We must therefore place the reign of Eadwald from about the death of Offa to a date short of 823-5, the reign of Beornwulf of Mercia, whose East Anglian contemporary was Aethelstan I. That Eadwald was an East Anglian king need not be doubted, though there is none but negative evidence on this question. In fact it is impossible to assign 'Eadwald Rex' at this date to any other kingdom. The affinity of his coinage with that of Mercia is explained by the little we know of the relations of Mercia and East Anglia. There seems no doubt that a distinct suzerainty of Mercia over East Anglia is indicated by the order of Offa for Ethelberht to be beheaded in 794 (see Hodgkin, *Polit. Hist. of England*, vol. i, p. 250) and that it continued until the East Angles transferred their allegiance to Ecgberht of Wessex and defeated Beornwulf of

Mercia and put him to death in 825-6. East Anglia was during this period, like Kent, a subject state of Mercia, and therefore its coinage like that of Kent has a counterpart in the coinage of Mercia. Apart from the coins of Offa and Coenwulf which have the names of Archbishops of Canterbury or the mint-name Dorovernia, there are reverse designs and moneyers' names on Offa's and Coenwulf's coins which are undoubtedly Kentish. Similarly other of their coins are East Anglian. It is not certain how this identity of coinage between subject-states should be explained; but it seems reasonable to suppose that the overlord either seized the mint of the subject-state but allowed the sub-king to retain a share in it, or made the subject-state issue part of its coinage in his name and for his profit.

Whatever the cause, it is quite evident that both the Kentish and East Anglian mints devoted part of their service to the Mercian overlord, and the work of Lul and Wihtred, Eadwald's moneyers, for Offa and Coenwulf establishes a date shortly before 800 for the accession of Eadwald to the throne of East Anglia. He may well have been the successor to the unfortunate Ethelberht who died in 794 and whose only known moneyer, Lul, is now found on the new coin of Eadwald.

Cnut

Hildebrand, type H (B.M.C. xvi) of Chester (Gunleof), E. of Plat-form by Chapel.

Richard II

Penny of York.

Henry V

Penny of York. *Obv.* ✠ HENRIQVS REX ANGLIE
Rev. ✠ CIVITATIS EBORACI

Miscellaneous English

Edward IV: York penny.
Elizabeth: Sixpence, 1565.
James I: Harrington farthing.
William and Mary: farthing, 1692-4?
George III. Counter imitating spade guinea.
" " Forgery of shilling, 1817.
" " Halfpenny.
" " Farthing.
George IV. Farthing.

Portugal

Dinheiro of D. Diniz, 1279-1325. *Texeira* I, pl. III, 2.

France

Two doubles tournois of Philip IV.

Obv. + PHILIPPVS REX. Cross with fleur de lis in one angle.

Rev. + MON · DVPLEX · REGAL ·. Châtel tournois between two fleurs. Cross above.

Brabant

Double mite of Marie de Bourgogne (1477-82). See Engel et Serrure, *Numismatique du Moyen Âge*, p. 1167, cp. fig. 1773.

Poland

Grosso of Stanislas Augustus, 1765 (?).

Knights of Malta

One grano of Emmanuel de Rohan, 1776 (?).

Nuremberg Counters

Three fifteenth-century counters.

One counter by Hans Krauwinckel, 1588-1612.

Unidentified (lead token ?)

Rev. Four diverging spokes with a pellet near margin in each sector.

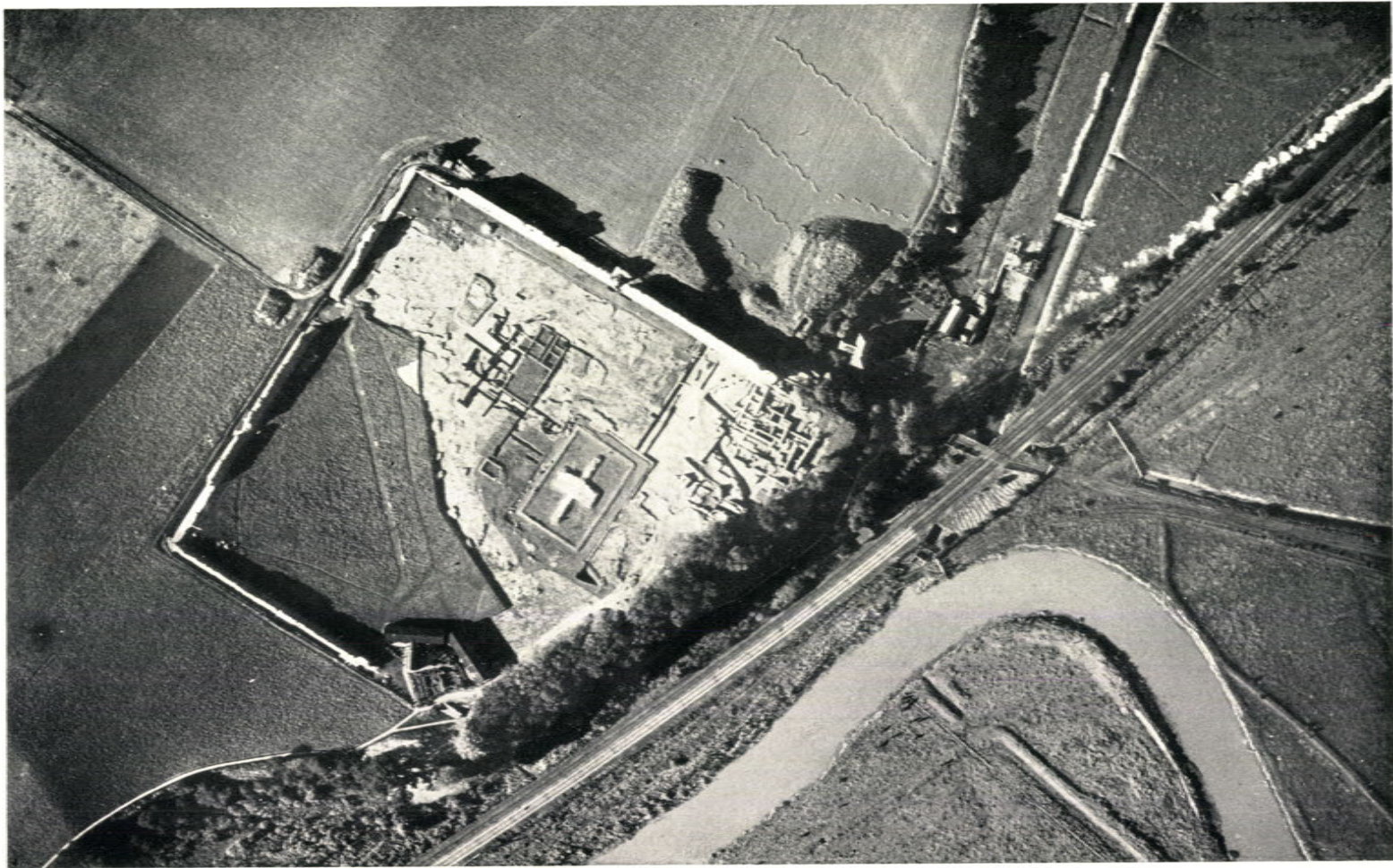

Aerial photograph of the Site

Royal Air Force, Official—Crown Copyright reserved

Published by the Society of Antiquaries of London, 1928

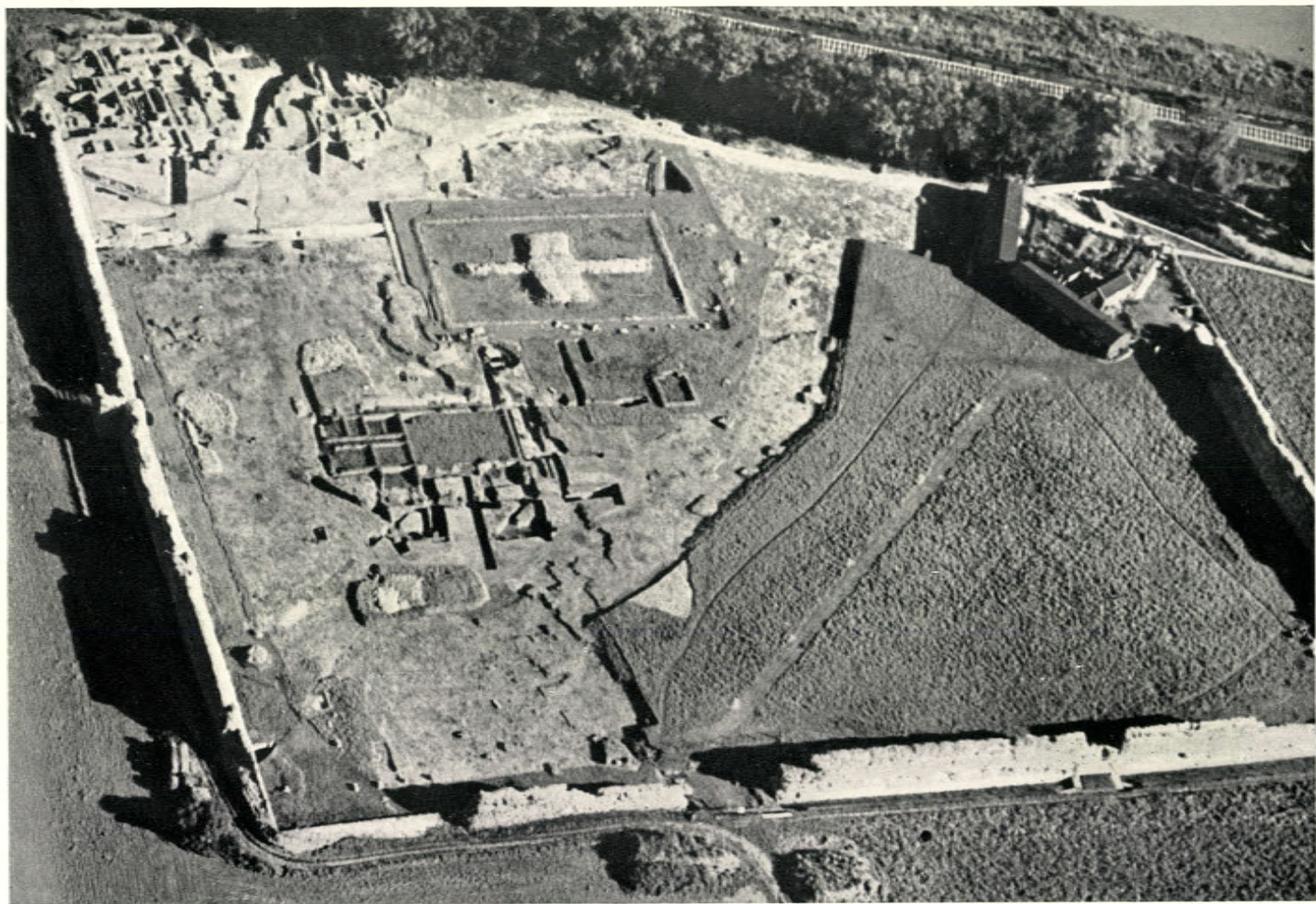

Aerial photograph from the west, showing area from which the surface soil has been removed, pp. 1-9

Royal Air Force, Official—Crown Copyright reserved

Published by the Society of Antiquaries of London, 1928



Fig. 1. General view of N.E. corner of fort. A. Site III, p. 13; B. chapel, p. 34; C. concrete foundation, p. 10; D. outer ditch, p. 18; E. mixing floor, p. 10; F. inner ditch, p. 18



Fig. 2. Site III. A. W. wall of 1st house; B. W. wall of 2nd house; C. S. wall of 1st house; D. S.W. angle of 2nd house; E. E. end of chapel; F. outer ditch; G. inner ditch; H. foundation of E. wall of fort. Cf. plan, pl. XXXIX



Fig. 1. Site III. A. S. wall of room 15, 1st house, p. 13; B. W. wall of room 16, 2nd house, p. 15; C. wall of room 1, bath building, p. 24



Fig. 2. Site III. A. wall of hypocaust of 1st house, p. 14; B. E. wall of room 6, 2nd house, p. 15; C. E. wall of room 4 of bath building, p. 24; D. foundation of E. wall of fort, p. 23



Fig. 1. Site III. A, opus signinum floor of room 5, 1st house, p. 15; B, B. walls of 2nd house; C, foundations of 1st house, p. 13



Fig. 2. Site III. A, A, doorways into room 7, 2nd house, p. 17; B, inserted opening in N. wall of room 8, 2nd house, p. 17



Fig. 1. Site III. Jamb of doorway between rooms 7 and 8, 2nd house, showing recess for sill, p. 17



Fig. 2. Site III. E. wall of room 6, 2nd house. A. ground level when wall was built; B. double lacing course of tiles, p. 16



Fig. 1. Site III. Inserted opening in N. wall of room 8,
2nd house, p. 17

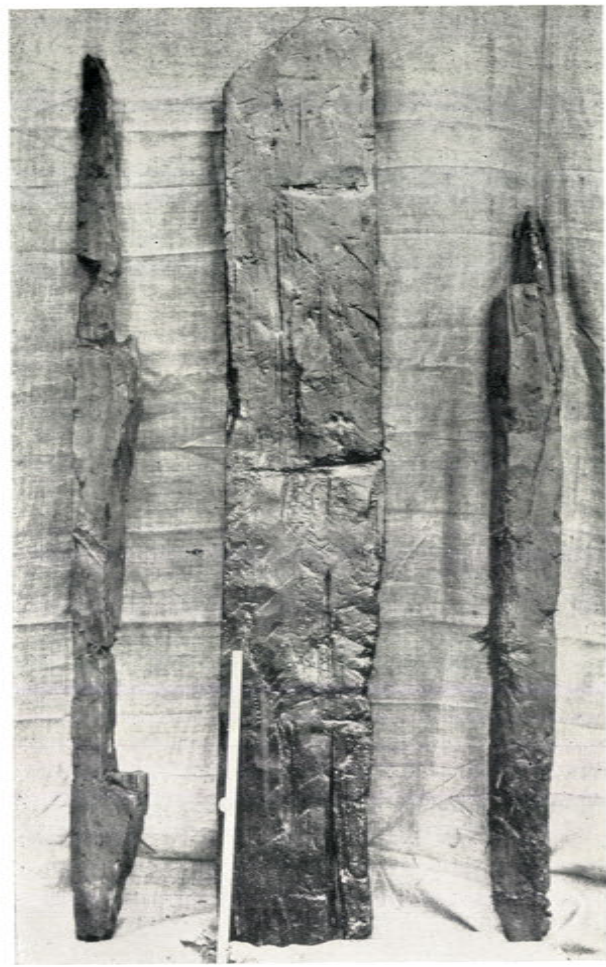

Fig. 2. Wood from pit 17, p. 28



Fig. 1. Site III. Foundations under line of N. wall of fort. A, A, A. foundations of 1st house; B, B. foundations of 2nd house; D. broken end of N. wall of fort; E. portion of N. wall of fort, p. 18. Cf. plan, Pl. XLV



Fig. 2. A. S.W. angle of 2nd house, Site III; B. foundation of E. wall of fort, passing over inner ditch, pp. 19, 23; C. N.E. angle of chapel, p. 34; D. mixing floor, p. 10

PLATE IX



Fig. 1. Outer ditch west of Site III. The full width of the upper part of the filling was not removed, p. 20

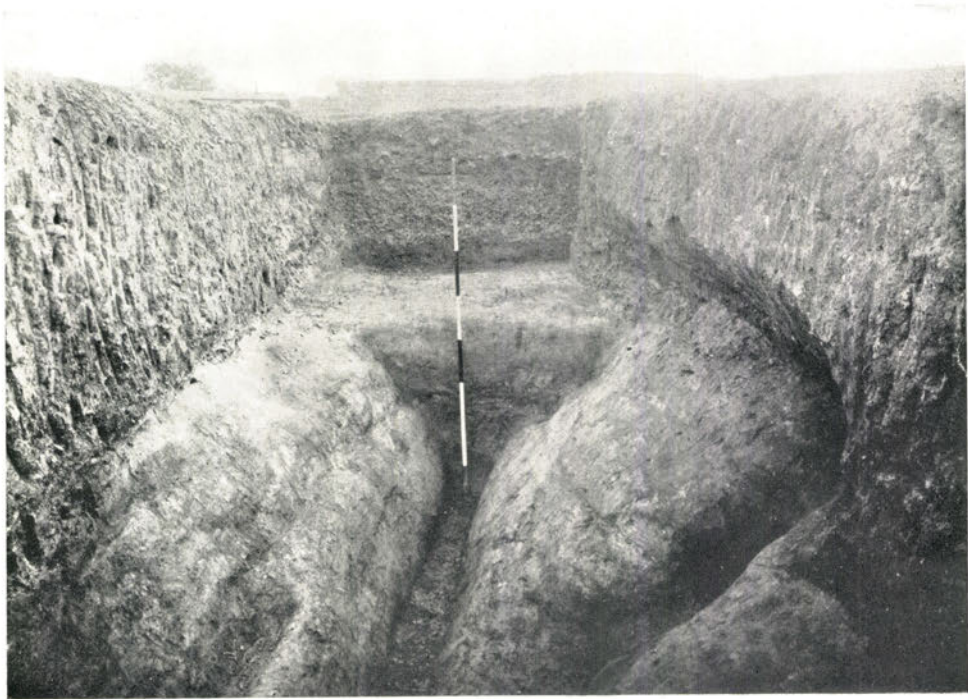

Fig. 2. End of inner ditch on N. side of E. and W. road, p. 18



Fig. 1. Foundation of E. wall of fort looking S., p. 23. A. N. wall of chapel; B. S. bank of inner ditch, p. 20; C. pit 26, p. 33



Fig. 2. Foundation of E. wall of fort looking N., p. 23. A. pit 26, p. 33; B. S. wall of 2nd house, Site III; C. surface of foundation of E. wall of fort at higher level, p. 23; D. N. side of inner ditch, p. 20



Fig. 1. Site III. A. E. wall of 2nd house, room 13; B. S. wall of 1st house, room 19; C. partially cut away foundation of E. wall of fort, looking S. in room 13 of 2nd house, showing post-holes, p. 23



Fig. 2. Site III. Bath building. A. room 3, B. room 4; C. room 2; D. room 1; E. furnace, p. 24



Fig. 1. Apse of chapel, p. 38

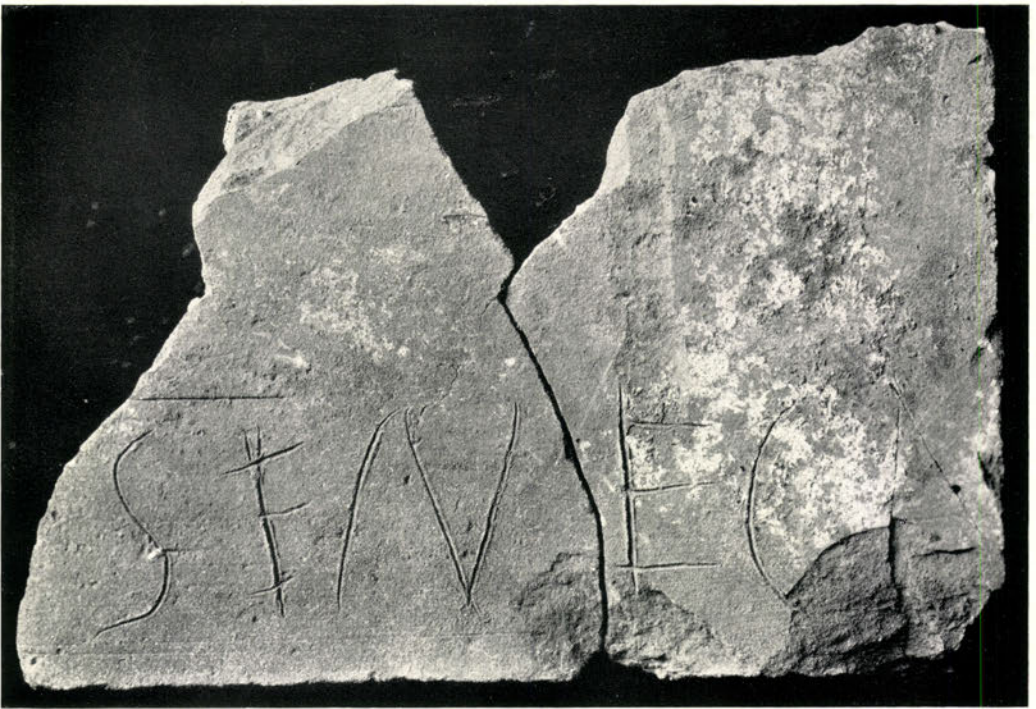
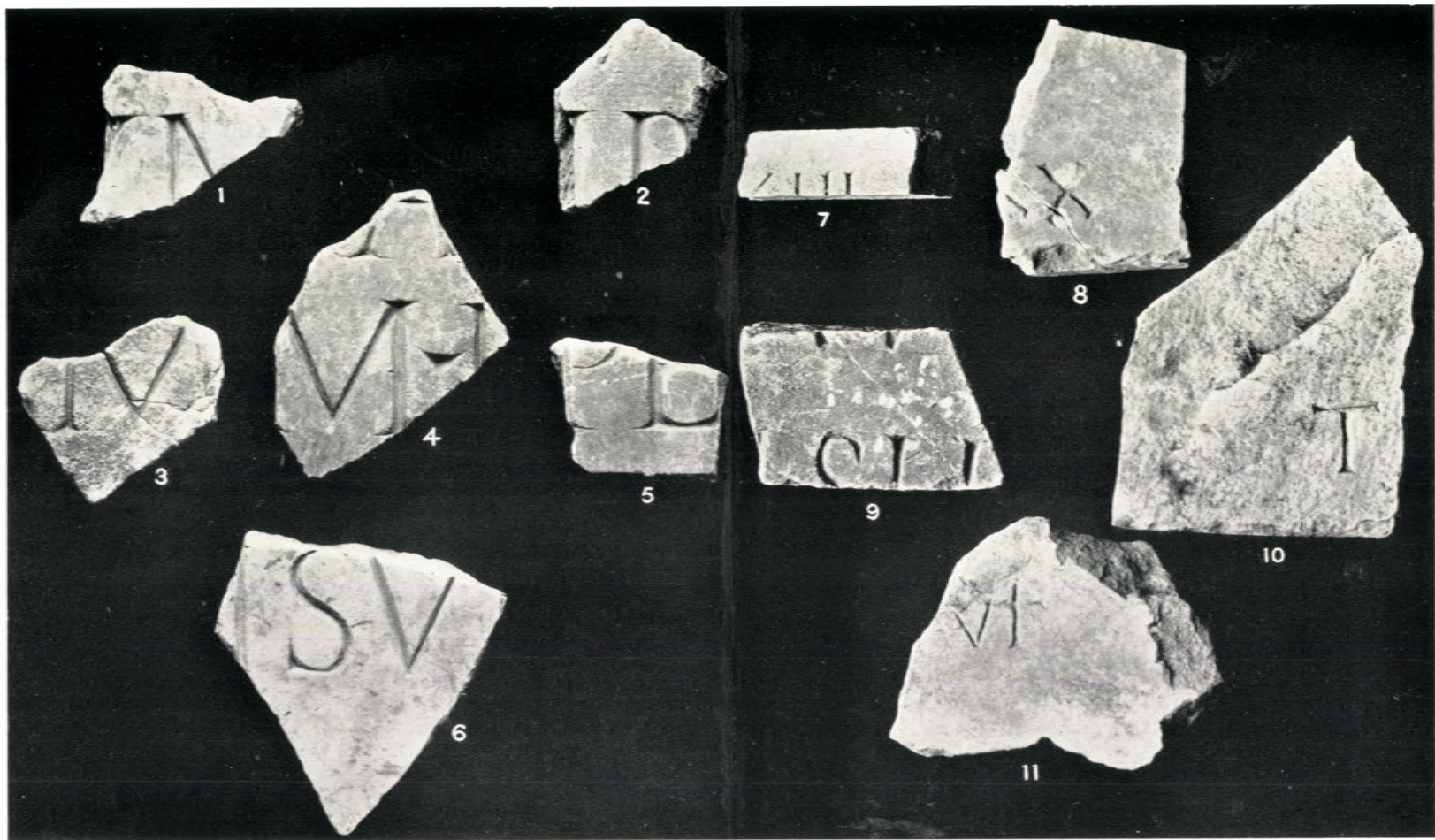

Fig. 2. Tile with graffito Seneca ($\frac{1}{2}$), p. 96



1-6. Fragments of an inscription on marble. 7-11. Various inscribed fragments of the marble casing ($\frac{1}{4}$), p. 12

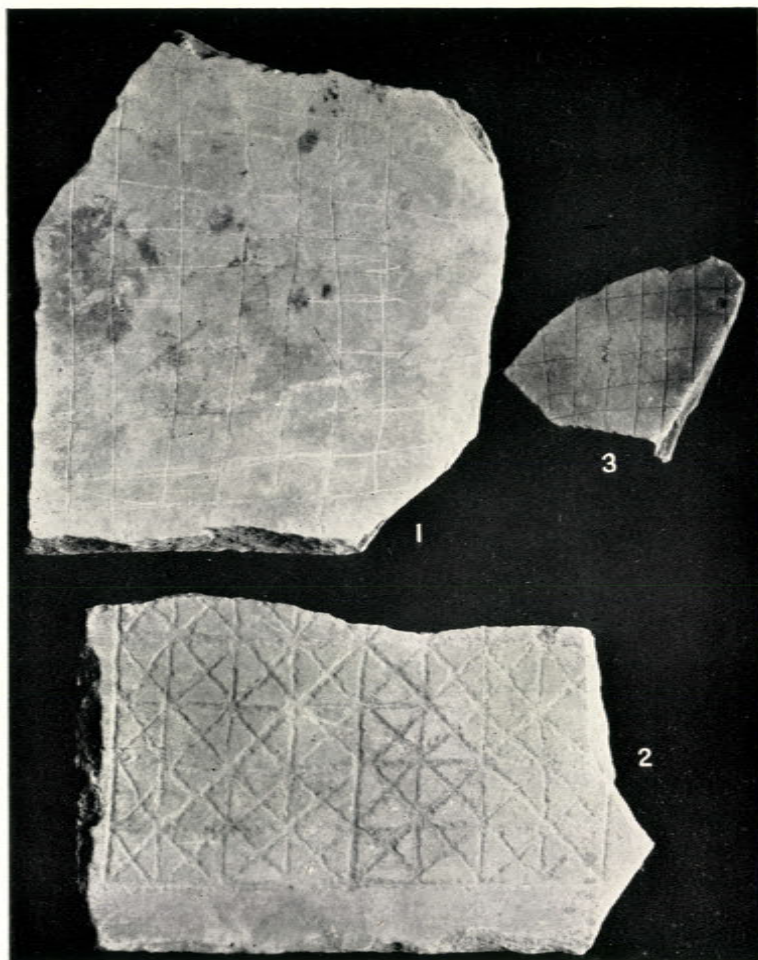

Fig. 1. 1, 2. Draught-boards on marble casing. 3. Draught-board fragment on Lower Greensand fragment ($\frac{1}{4}$), p. 13

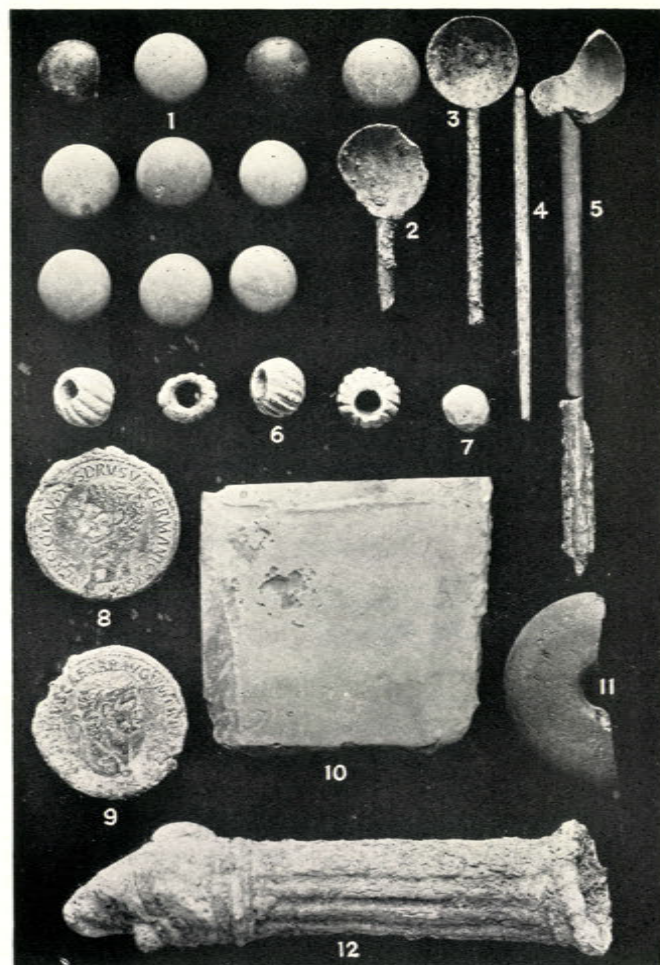

Fig. 2. Objects from pit 20 ($\frac{5}{8}$), p. 31

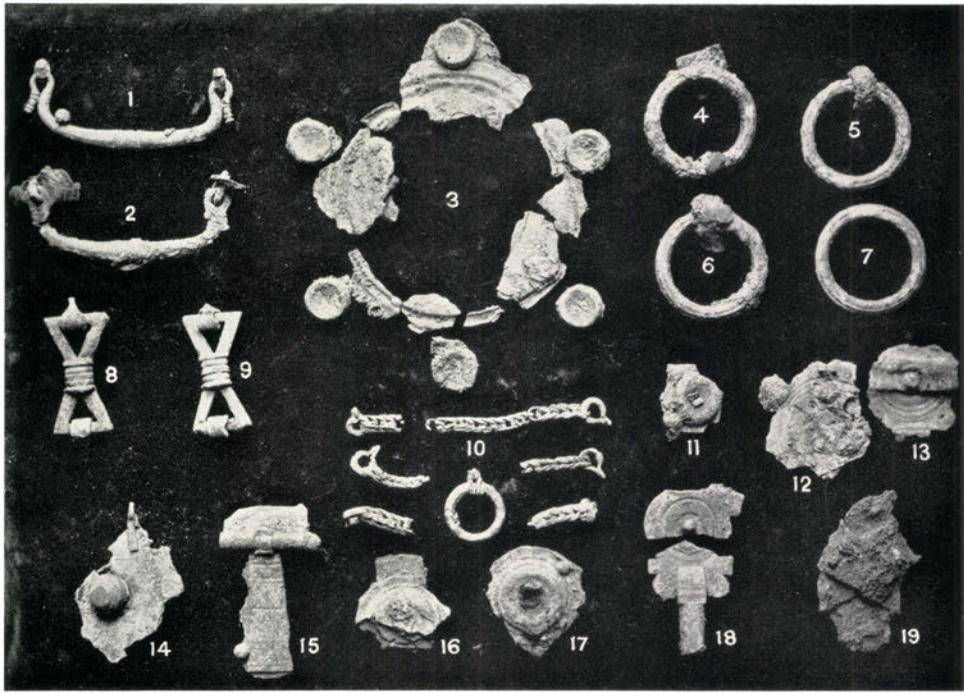

Fig. 1. Objects from pit 20 ($\frac{1}{3}$), p. 30

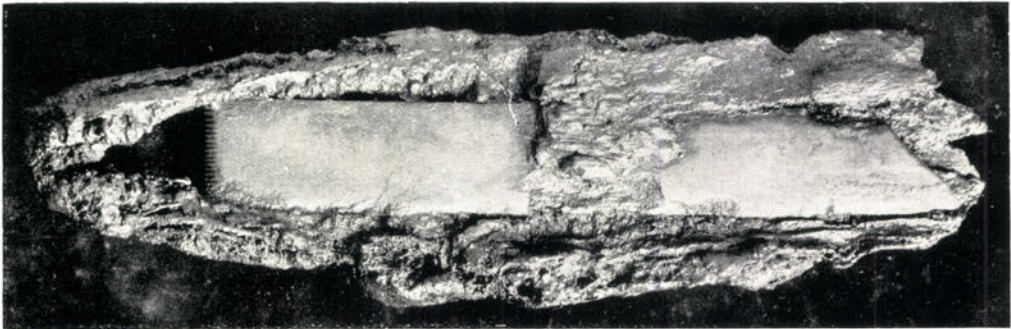
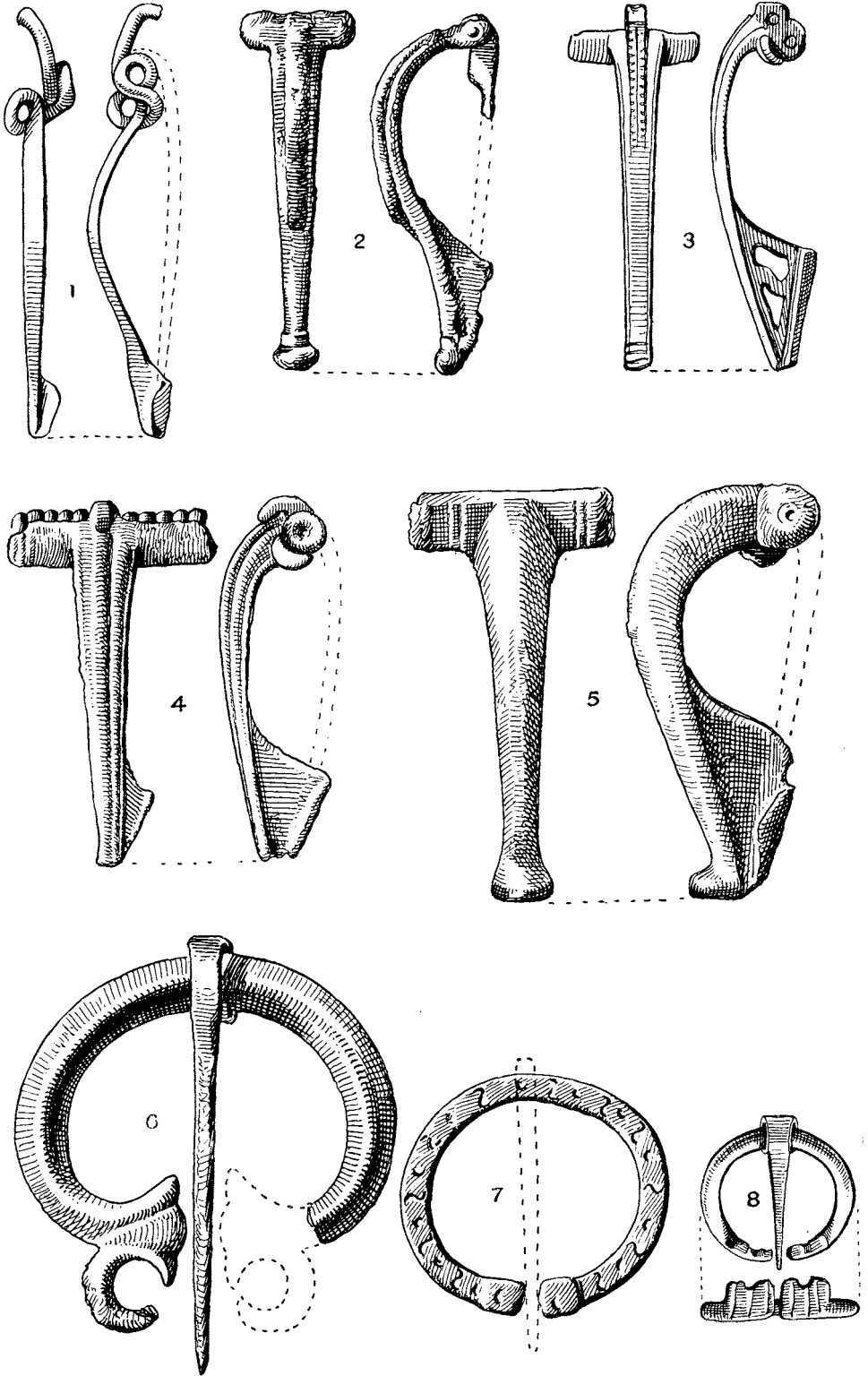

Fig. 2. Comb and shears in case from pit 20 ($\frac{1}{2}$), p. 31

PLATE XVI



Brooches ($\frac{1}{2}$), pp. 40-42

PLATE XVII

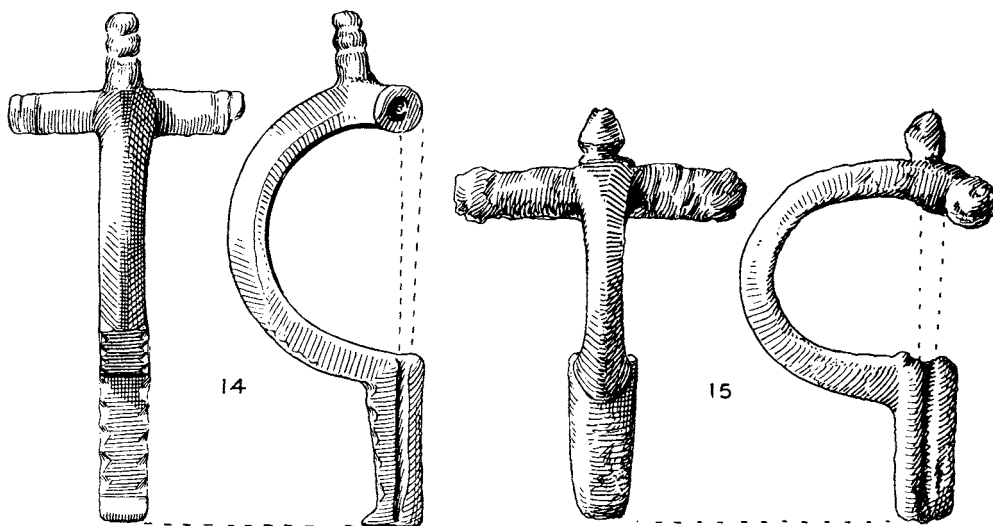
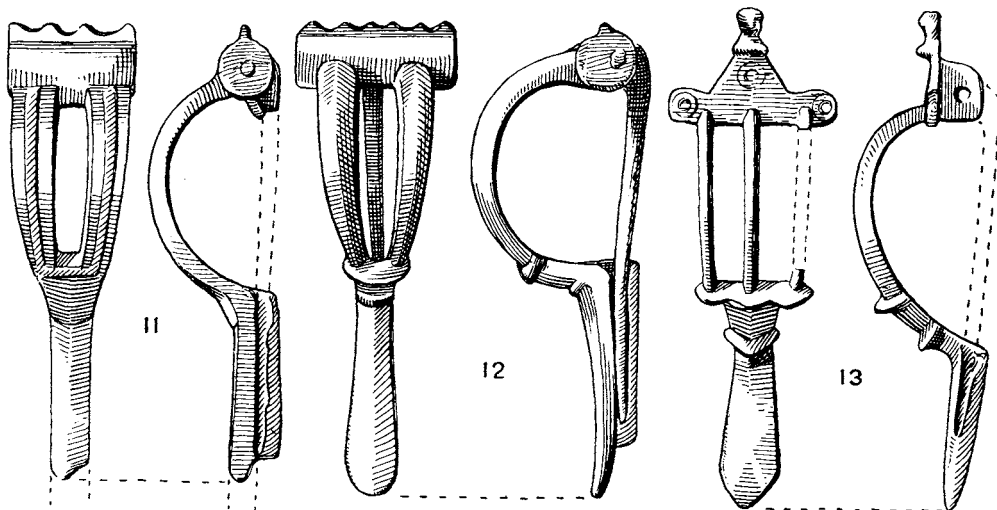
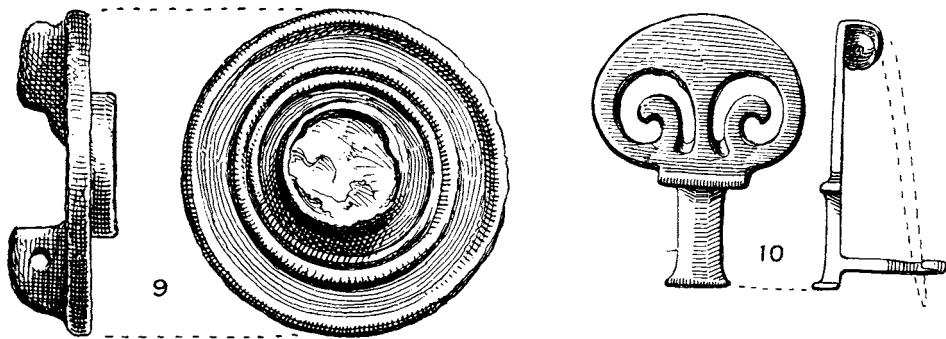

Brooches ($\frac{1}{2}$), pp. 42-3

PLATE XVIII

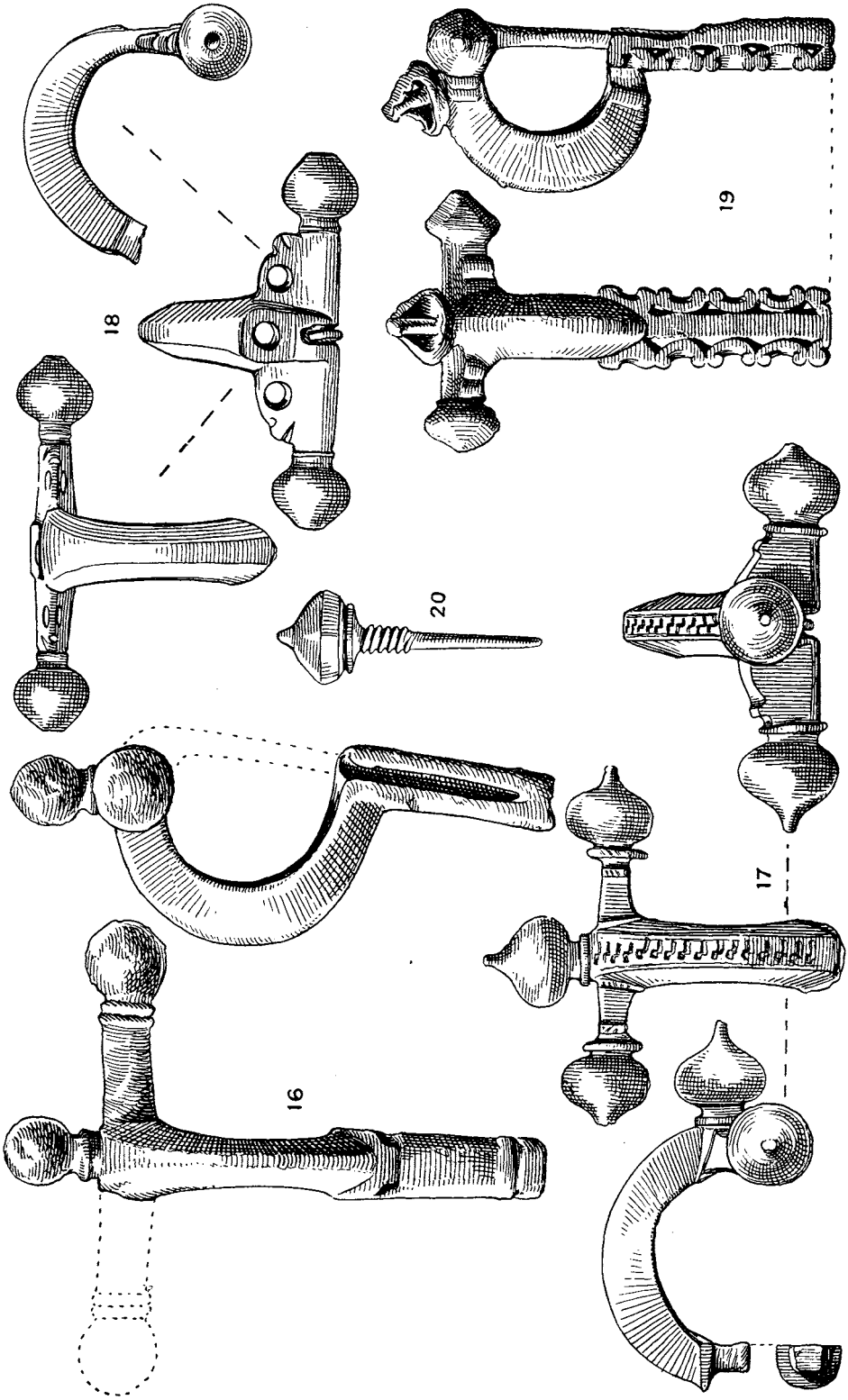

Brooches ($\frac{1}{2}$), pp. 44-5

PLATE XIX

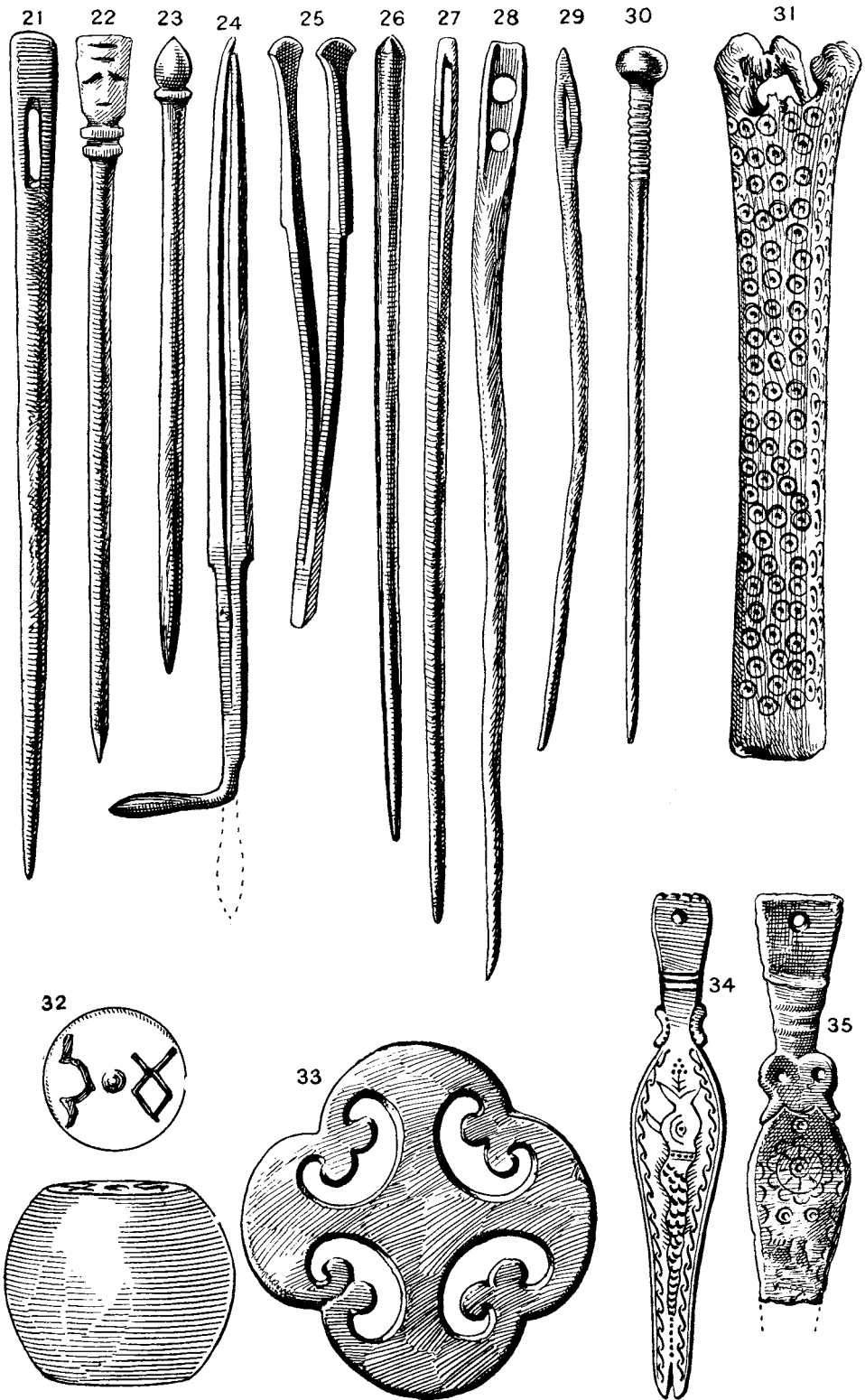

Various small objects ($\frac{1}{2}$), pp. 45-6

PLATE XX

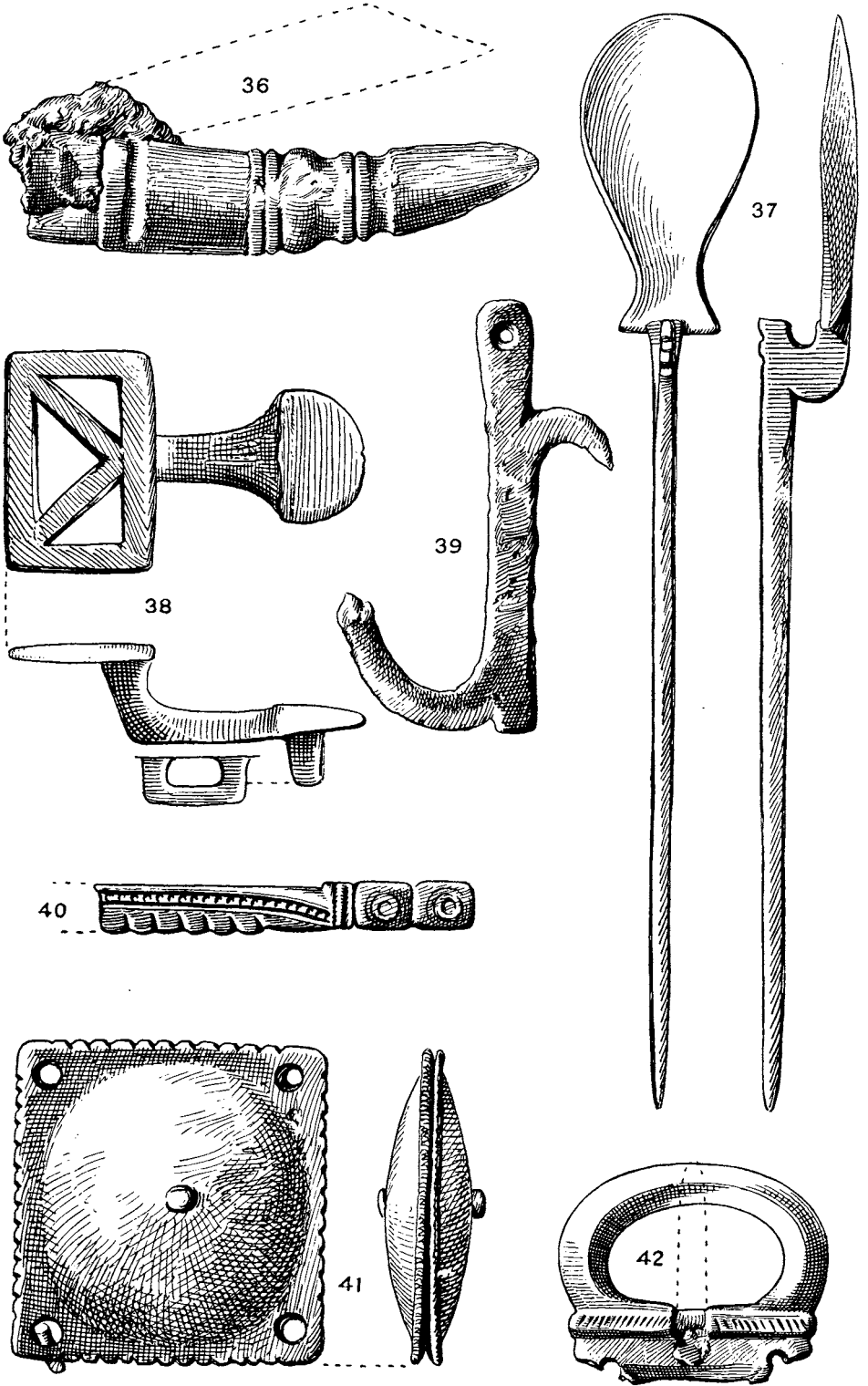

Various small objects ($\frac{1}{2}$), pp. 46-7

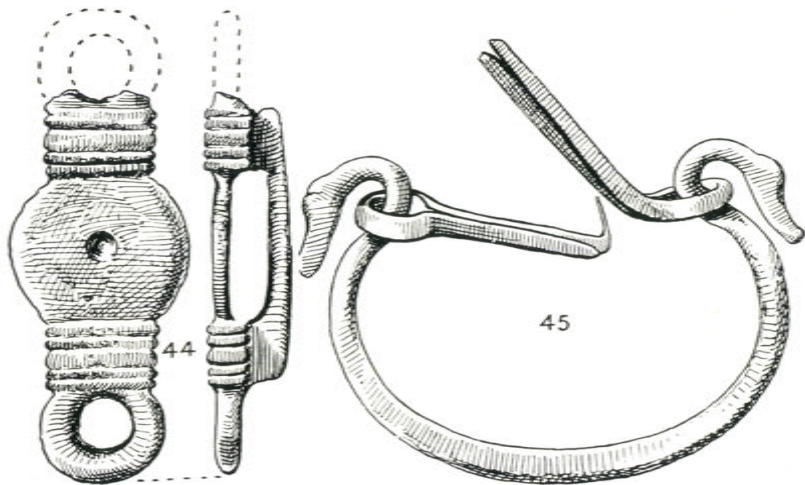
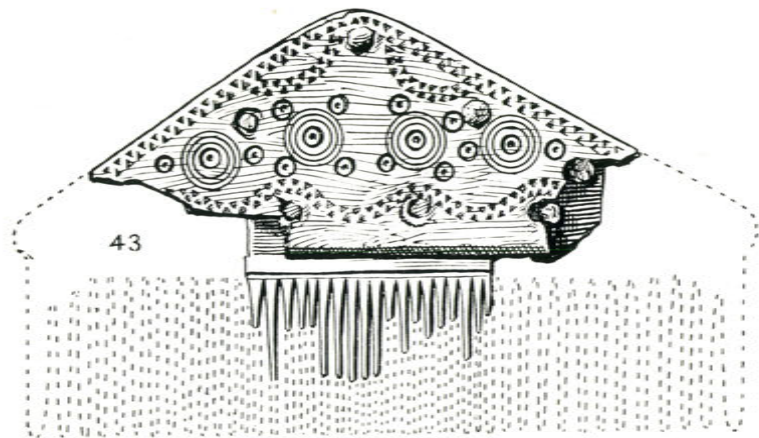

Fig. 1. Small objects ($\frac{1}{3}$), p. 47

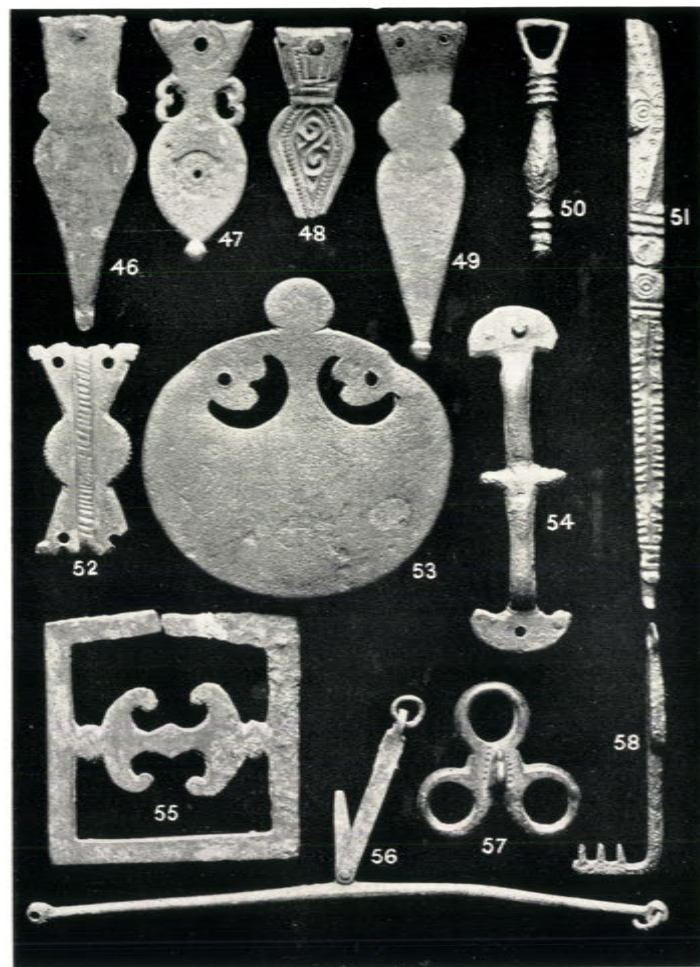
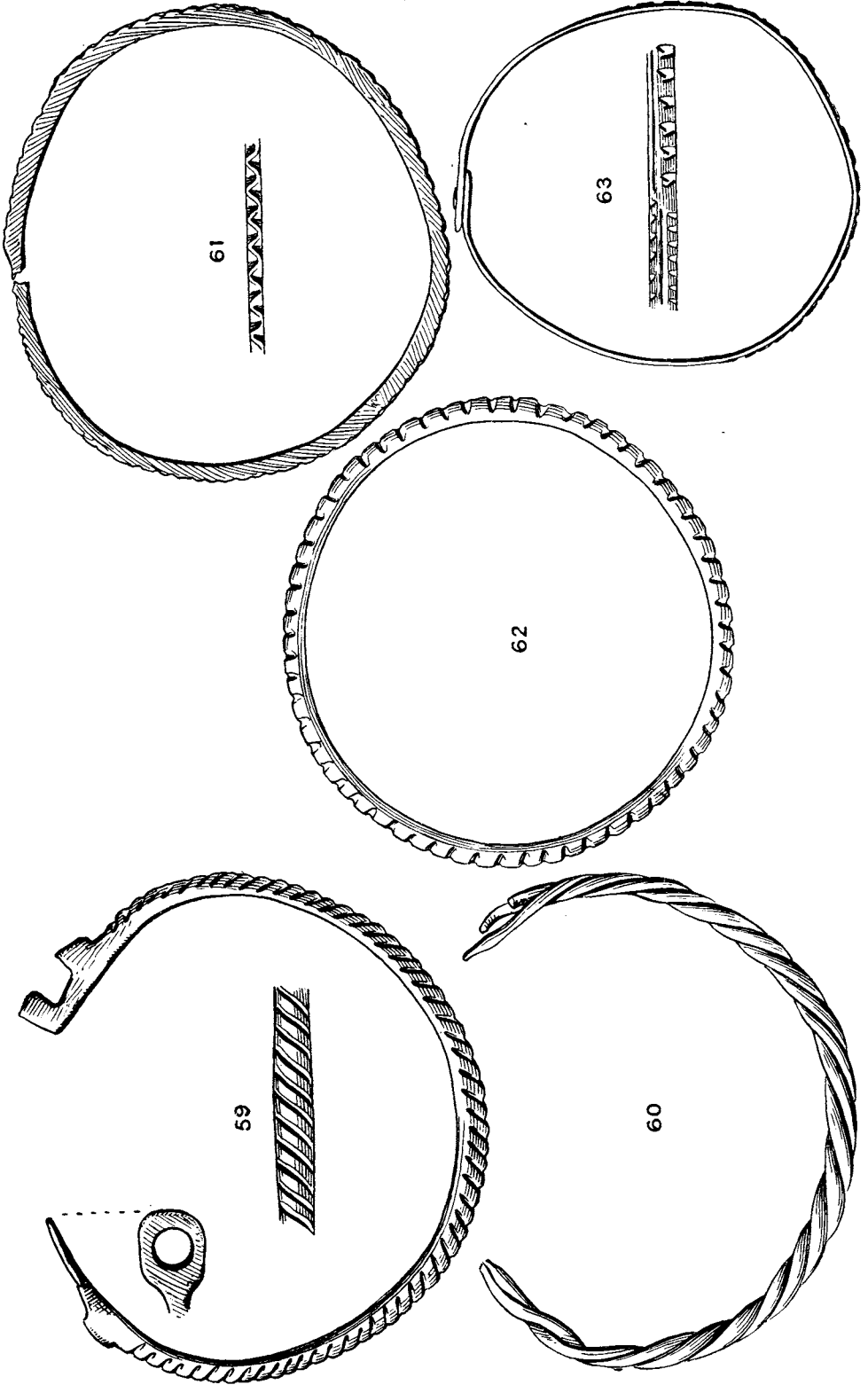
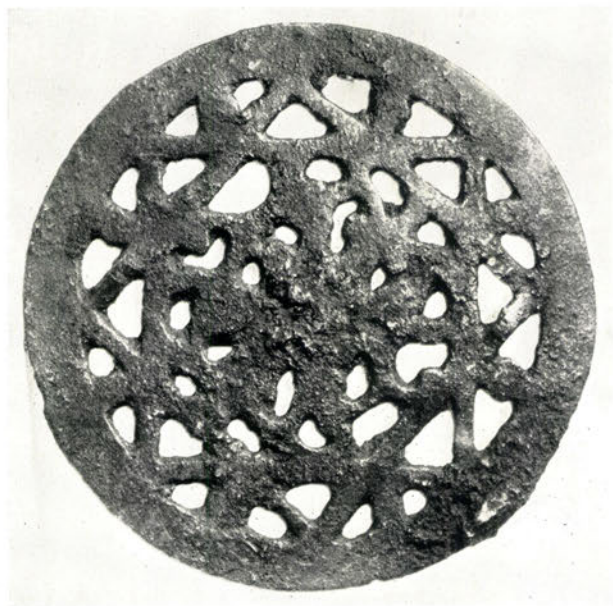

Fig. 2. Various small objects ($\frac{2}{3}$), pp. 47-9

PLATE XXII



Bronze bracelets ($\frac{1}{4}$), pp. 49-50



64



65

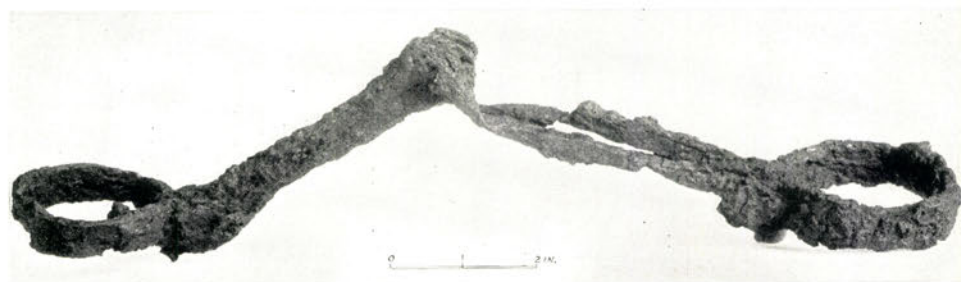

66

64, 65. Bronzes ($\frac{1}{4}$); 66. Iron shackles ($\frac{3}{8}$), pp. 50-1

PLATE XXIV

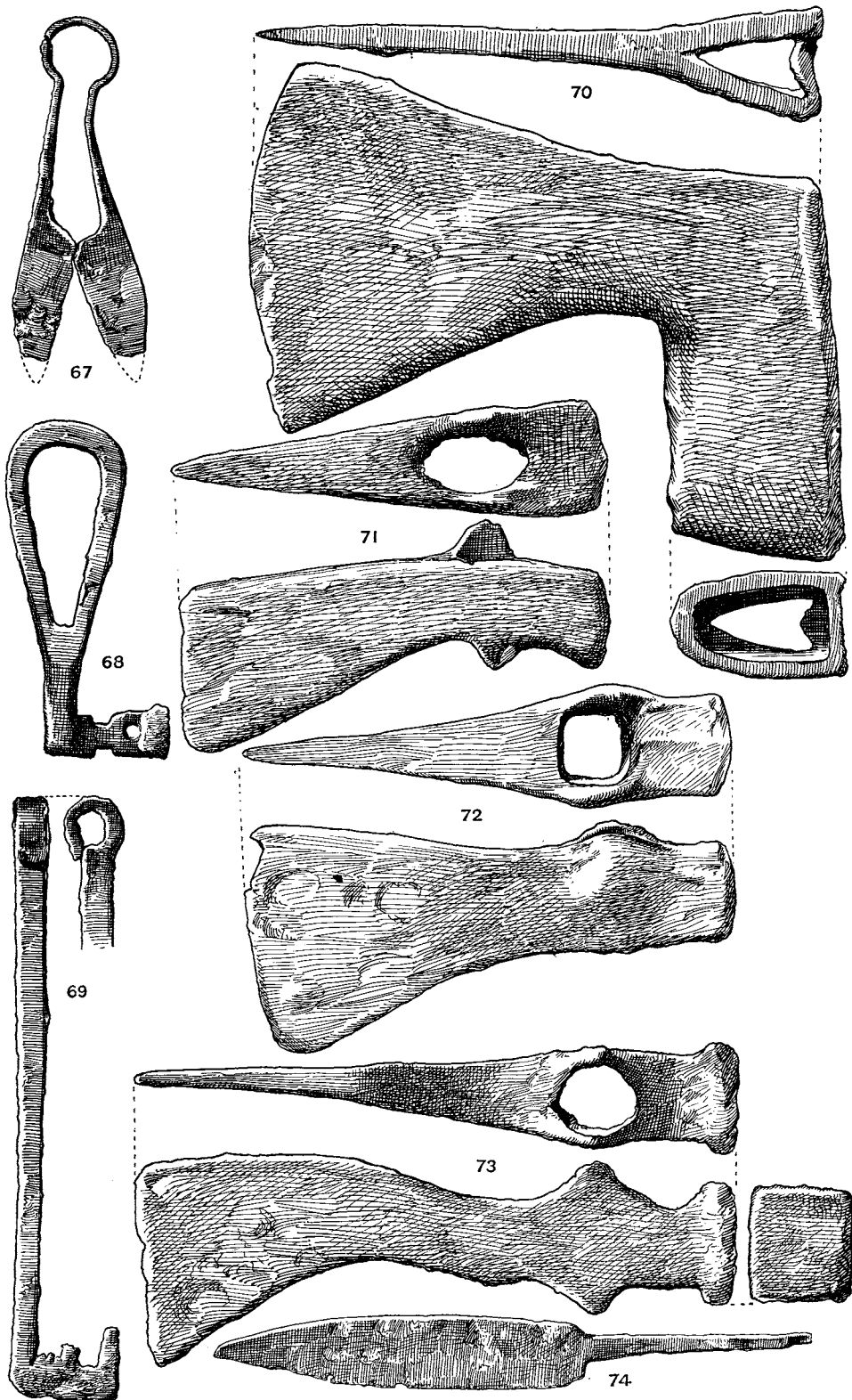

Iron objects ($\frac{1}{2}$), pp. 51-2

PLATE XXV

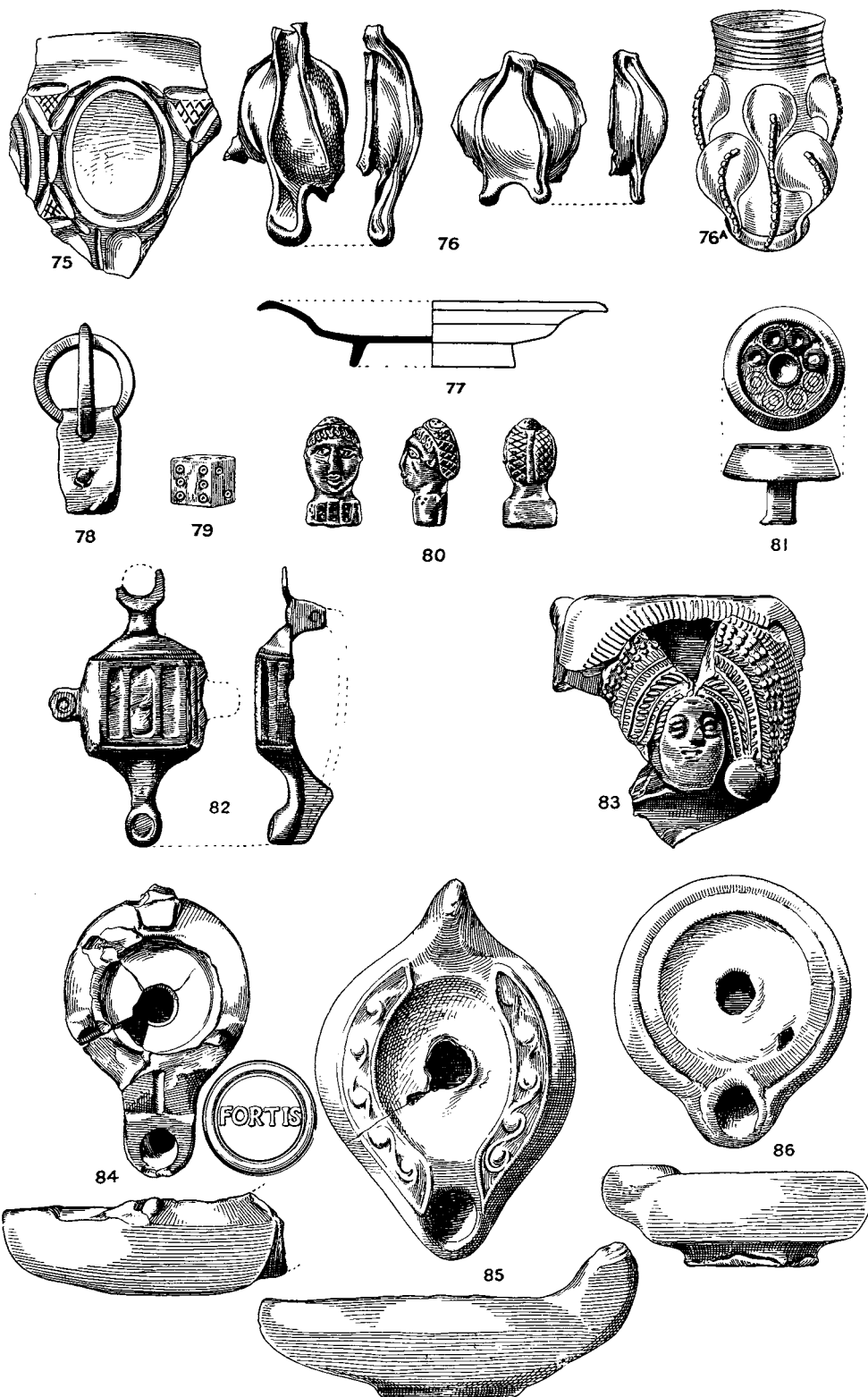

Various objects in glass, metal, and pottery: 75, 76 ($\frac{1}{2}$), p. 52; 77 ($\frac{1}{2}$), p. 52; 78-82 ($\frac{1}{2}$), p. 53; 83 ($\frac{1}{2}$), p. 105; 84-6 ($\frac{1}{2}$), pp. 92, 97

PLATE XXVI

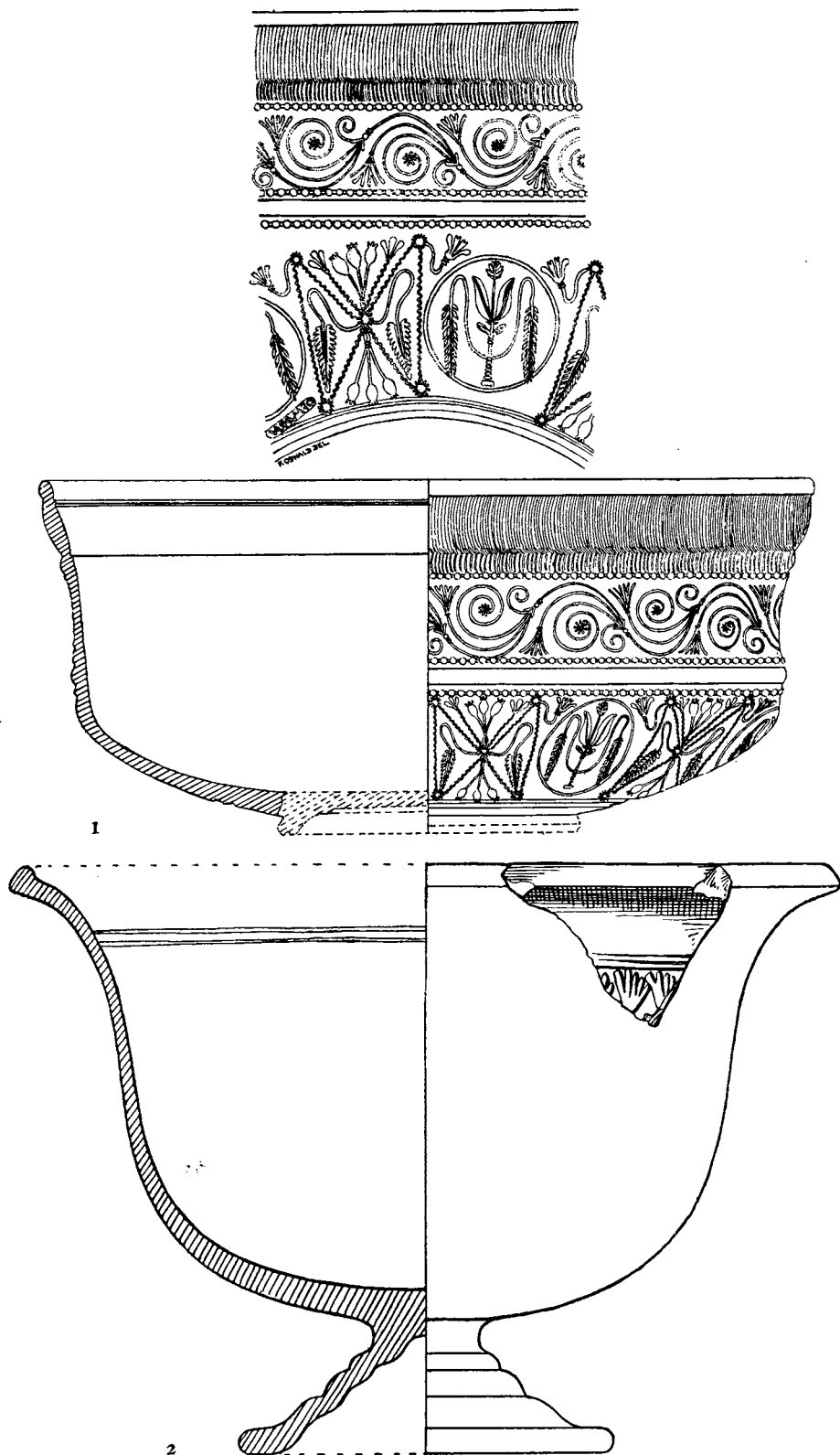

Decorated Samian: 1 ($\frac{1}{2}$), p. 70; 2, p. 54

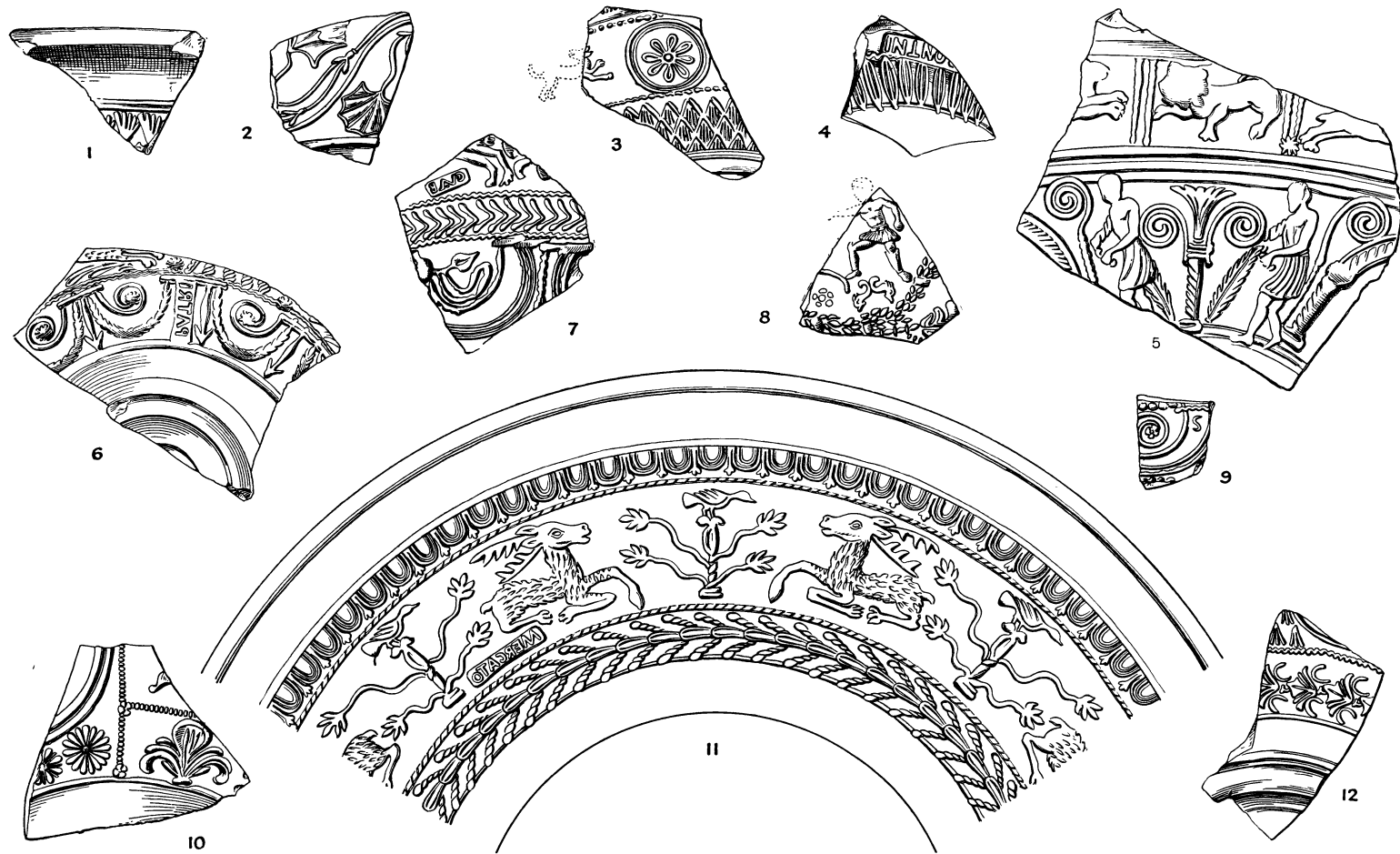

Decorated Samian ($\frac{1}{2}$), I, p. 54; 2, 3, p. 55; 4, p. 64; 5, p. 56; 6, p. 66; 7, p. 67; 8, p. 57; 9, pp. 64, 72; 10, p. 57; 11, p. 69; 12, p. 57

Published by the Society of Antiquaries of London, 1928

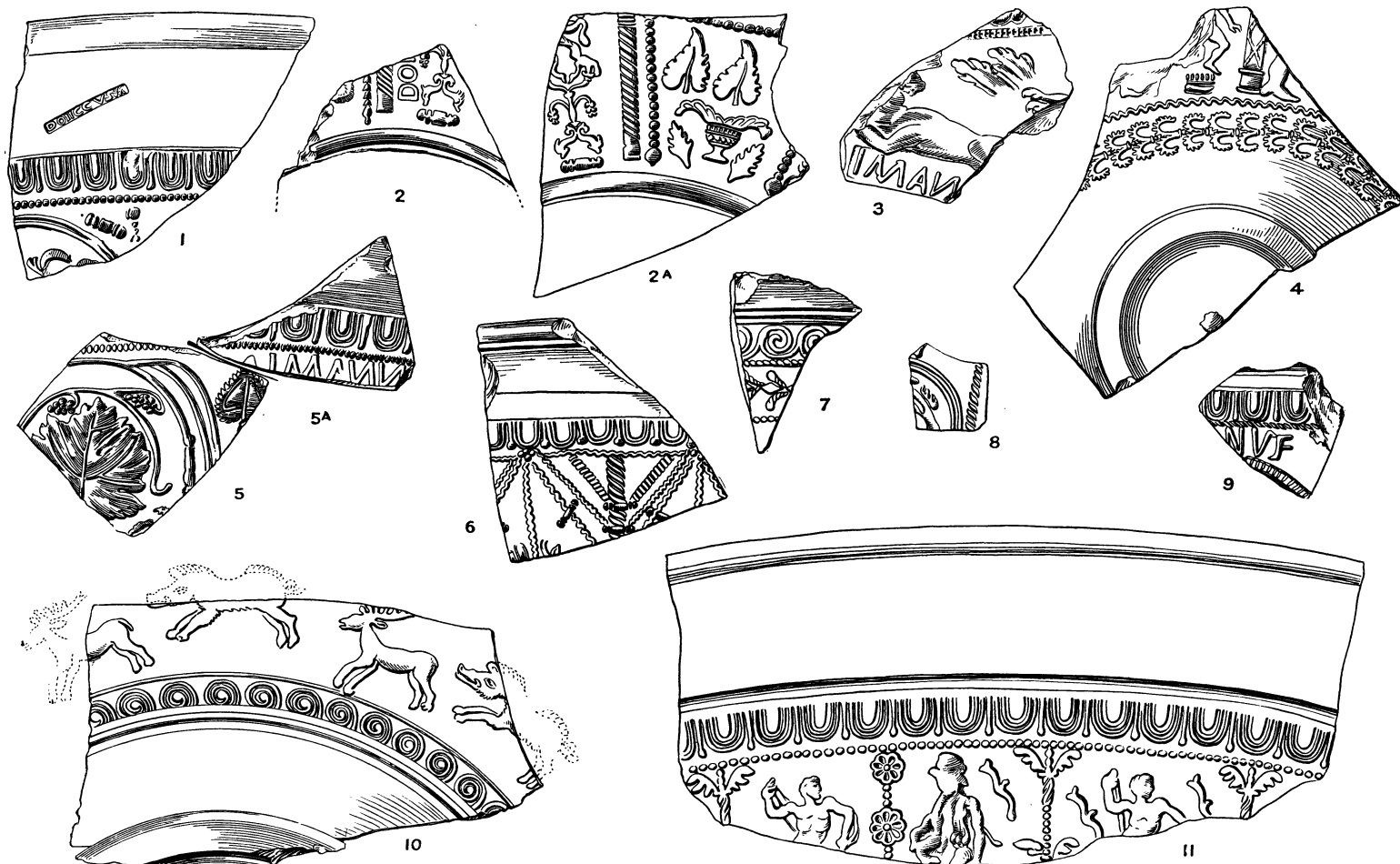

Decorated Samian ($\frac{1}{2}$), 1, 2, p. 68; 3, p. 63; 4, p. 57; 5, p. 62; 6, pp. 58, 66; 7, pp. 59, 67; 8, p. 59; 9, p. 64; 10, 11, p. 60



Fig. 1. Furrowed bead-rim olla, p. 99

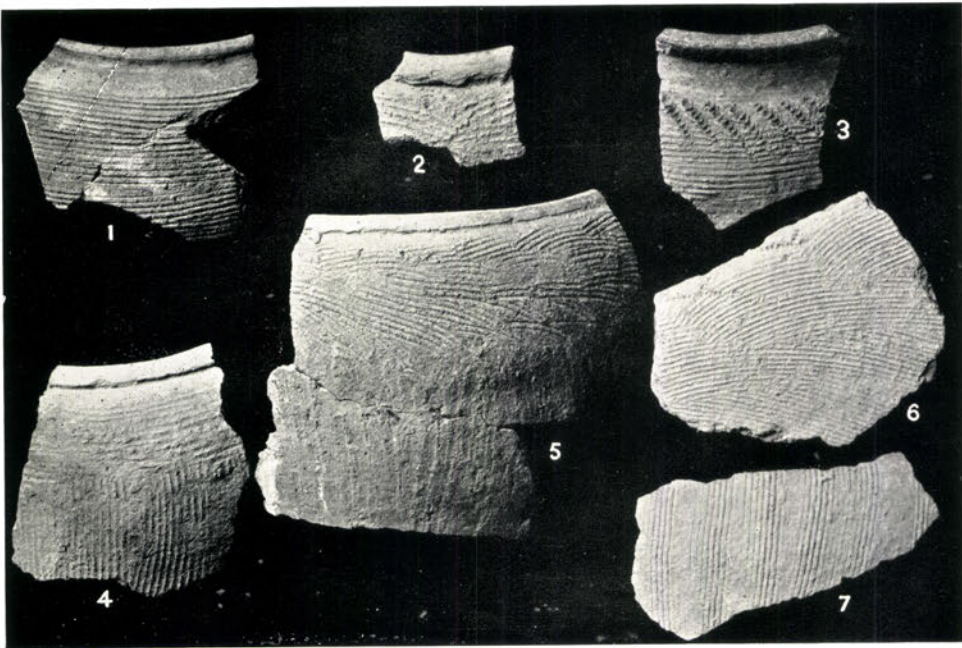
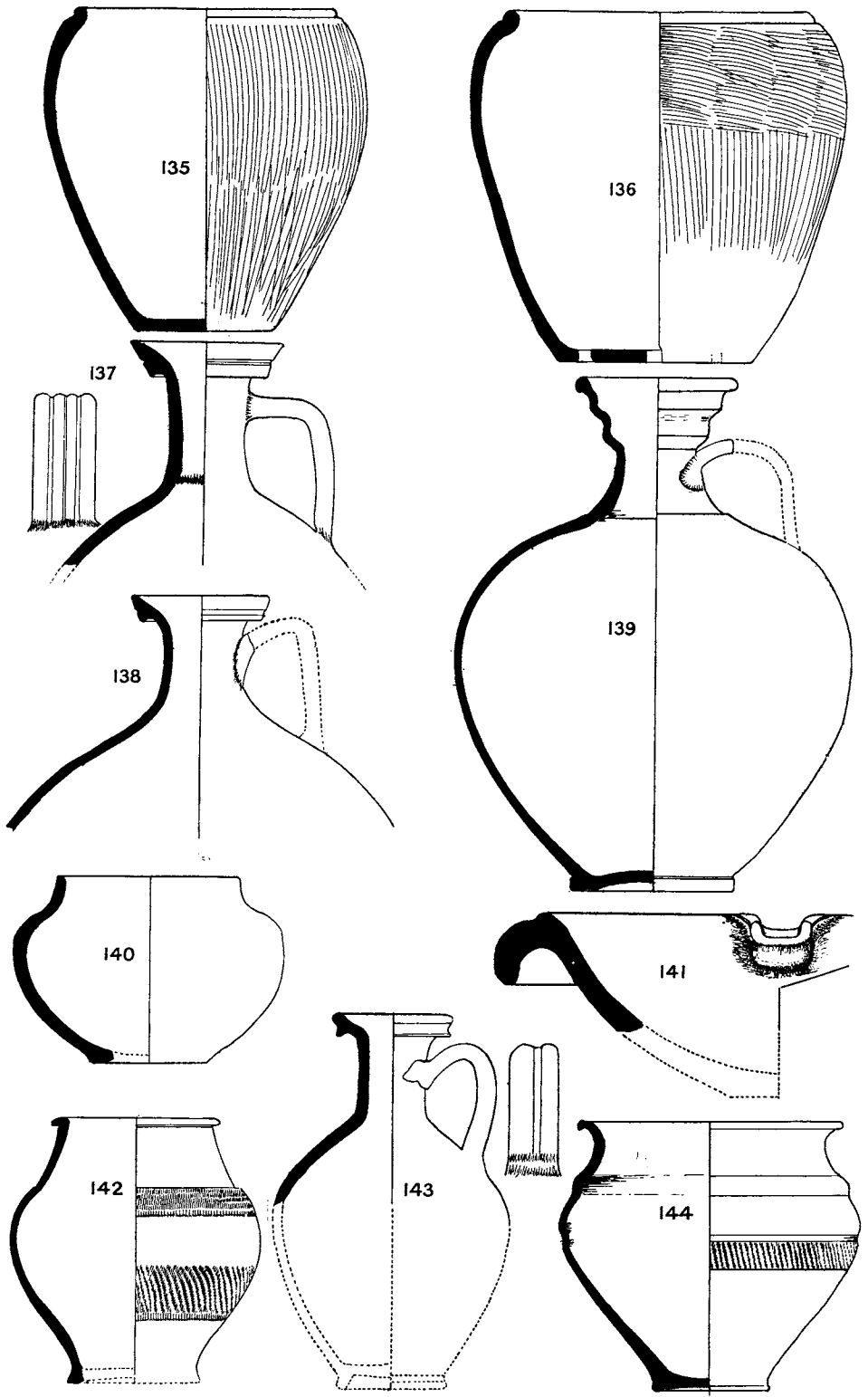

Fig. 2. Examples of furrowed ware, p. 98

PLATE XXX



Coarse pottery ($\frac{1}{4}$), pp. 99-100

PLATE XXXI

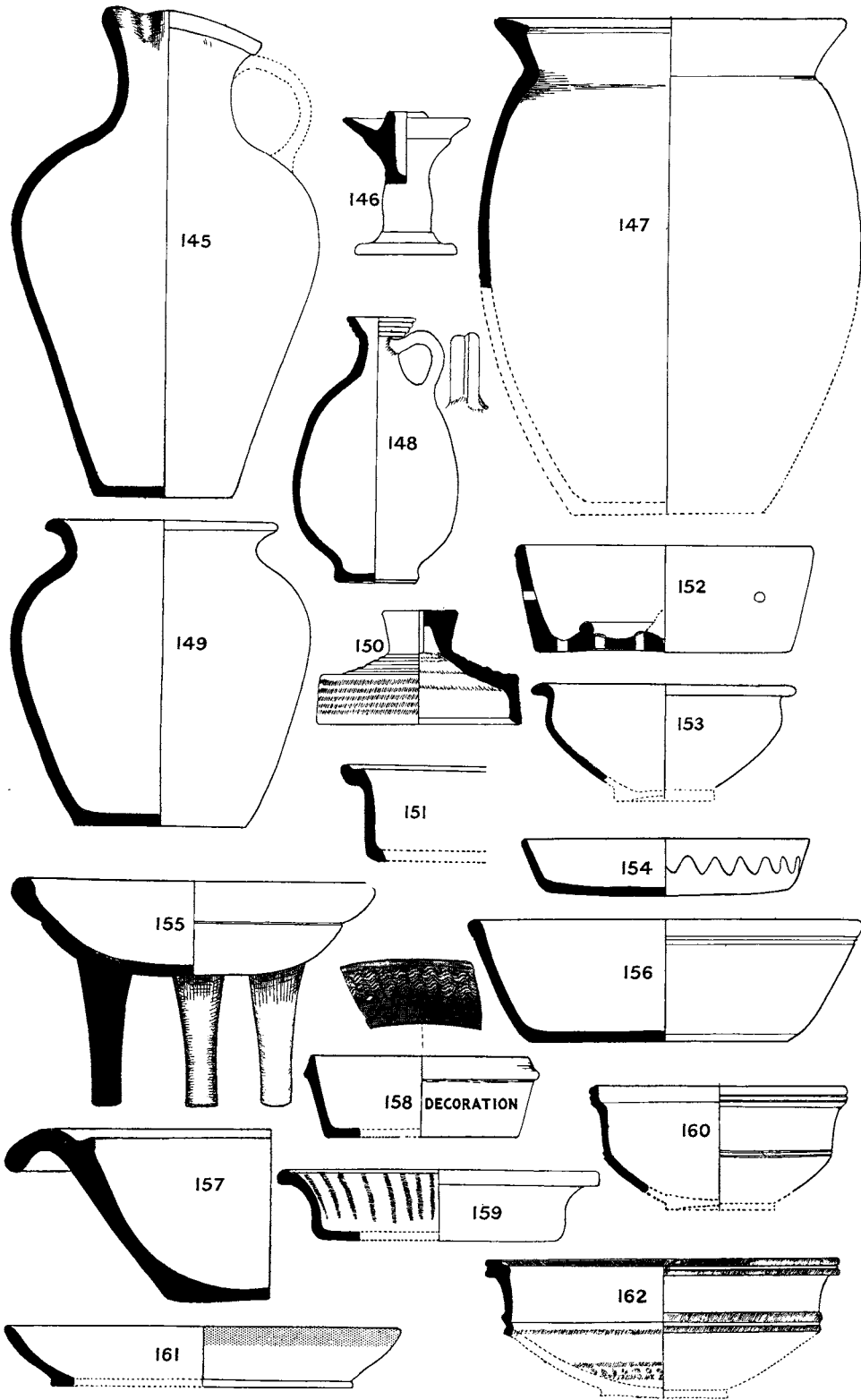

Coarse pottery ($\frac{1}{4}$), pp. 100-102

PLATE XXXII

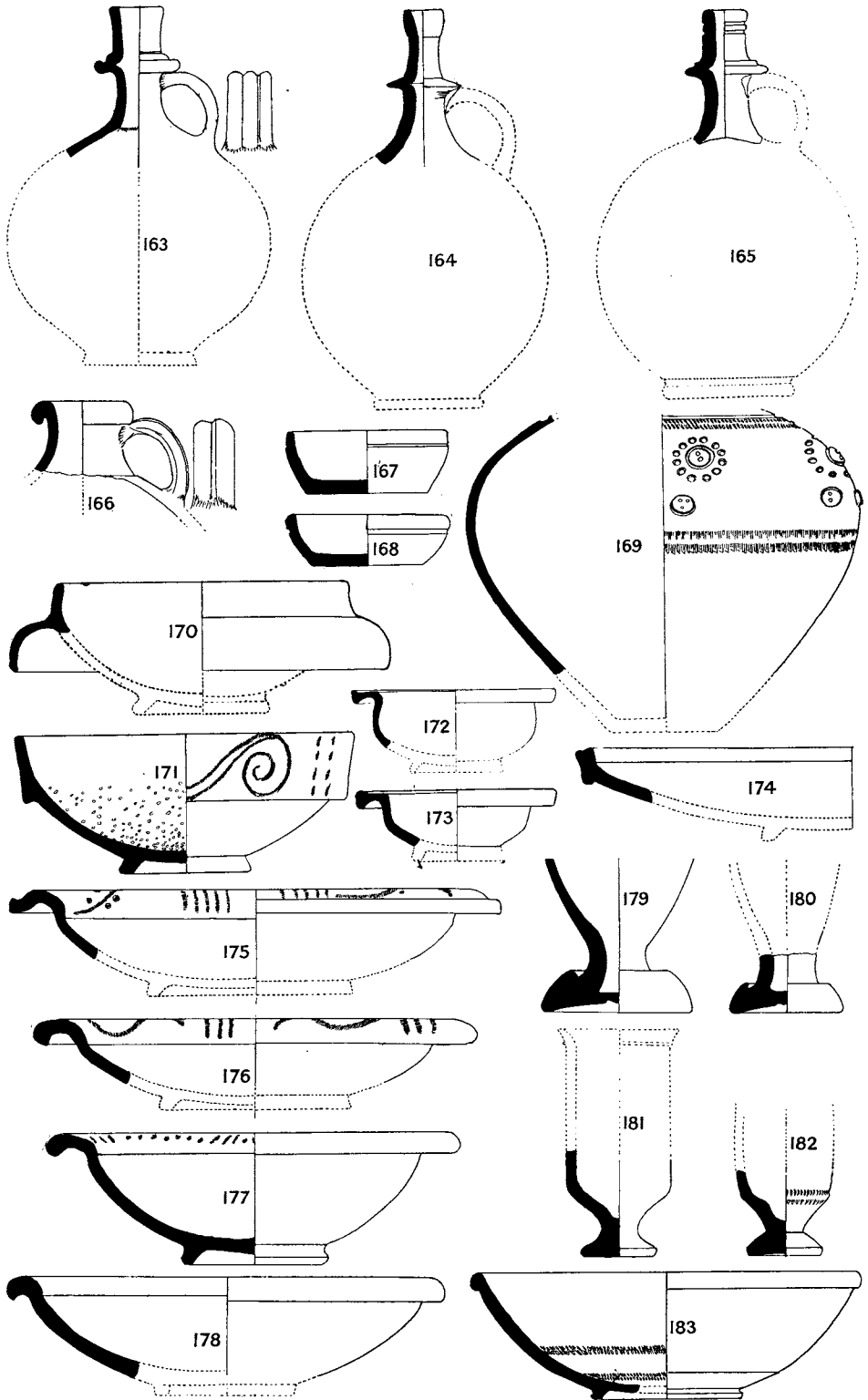

Coarse pottery ($\frac{1}{4}$), pp. 102-104

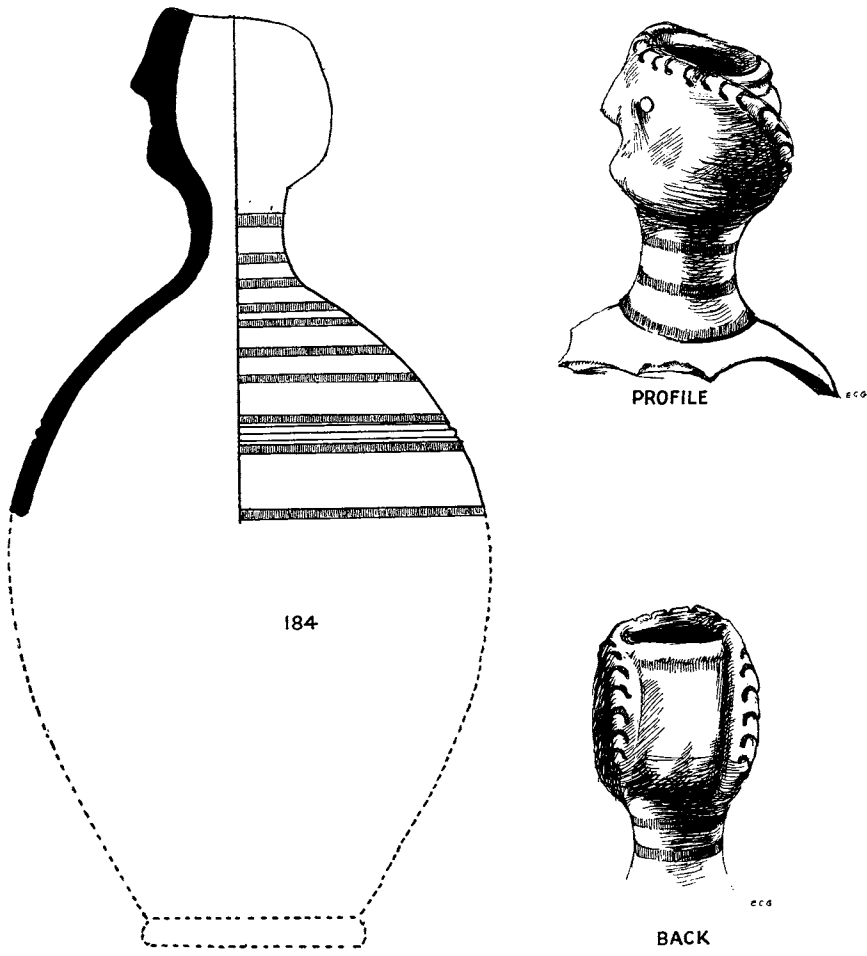

Coarse ware jug ($\frac{1}{2}$), p. 104

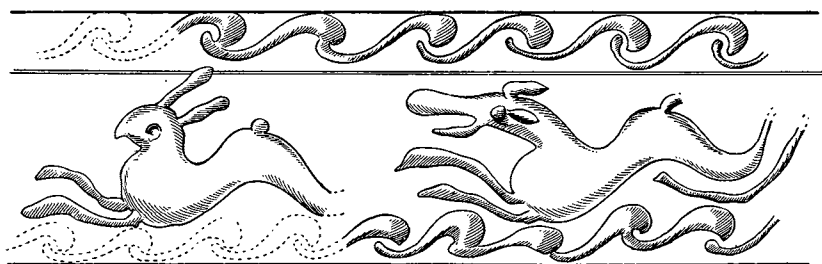
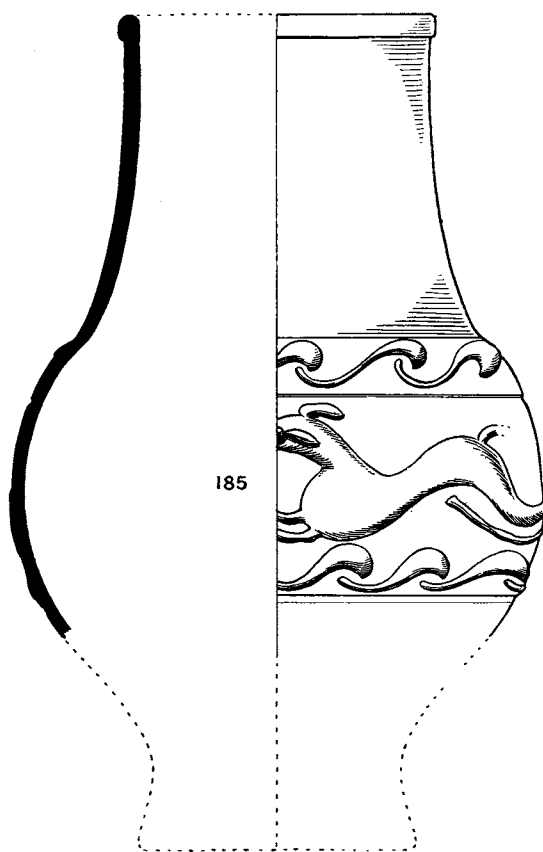

Coarse ware beaker ($\frac{1}{2}$), p. 104



Fig. 1. Fragment of upper part of Castor ware beaker with barbotine decoration ($\frac{1}{2}$), p. 105

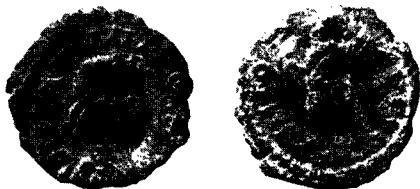

Fig. 2. Graffiti ($\frac{1}{2}$), p. 96

PLATE XXXVI



1



2



3

1. In Rev. E. A. Sydenham's collection; see p. 209, no. 8259 ($\frac{1}{2}$)
 2. = no. 19315, p. 226 ($\frac{2}{3}$)
 3. Coin of Eadwald, p. 228 ($\frac{1}{2}$)

KEY TO PLATE XXXVII OPPOSITE

1 = 3192	11 = 3880	21 = 6293	31 = 7680d
2 = 3234	12 = 3948	22 = 6302	32 = 7680f
3 = 3604	13 = 3949	23 = 6401	33 = 8102
4 = 3607	14 = 3952	24 = 7098	34 = 8162
5 = 3614	15 = 3953	25 = 7099	35 = 8226
6 = 3615	16 = 3957	26 = 7321	36 = 19310
7 = 3617	17 = 3960	27 = 7322	37 = 19312
8 = 3618	18 = 4382	28 = 7325	38 = 19313
9 = 3619	19 = 4964	29 = 7328	
10 = 3878	20 = 5078	30 = 7415	

PLATE XXXVII

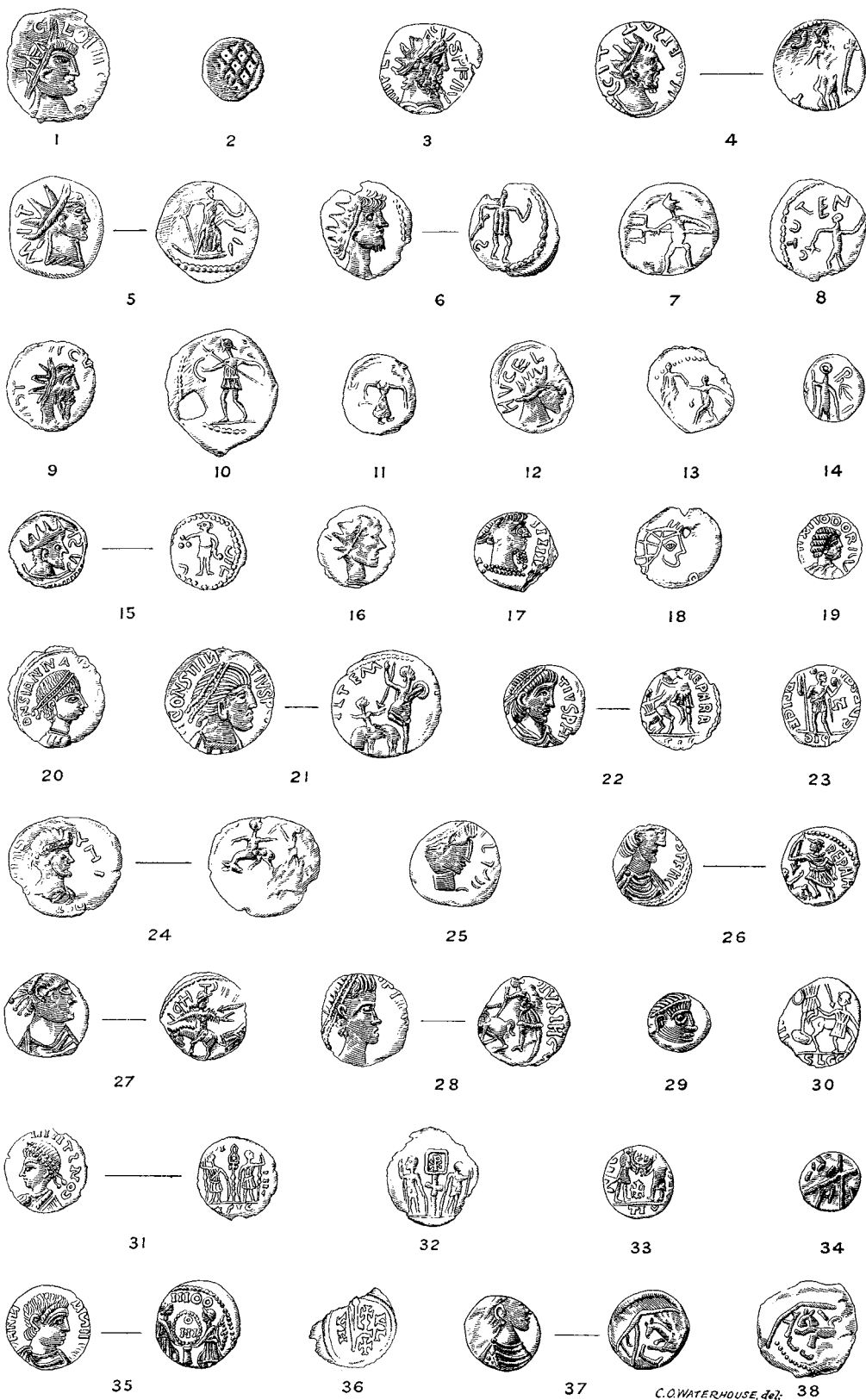

C. WATERHOUSE, del.

Various coins ($\frac{1}{4}$). For key see pl. XXXVI, opposite

Published by the Society of Antiquaries of London, 1928

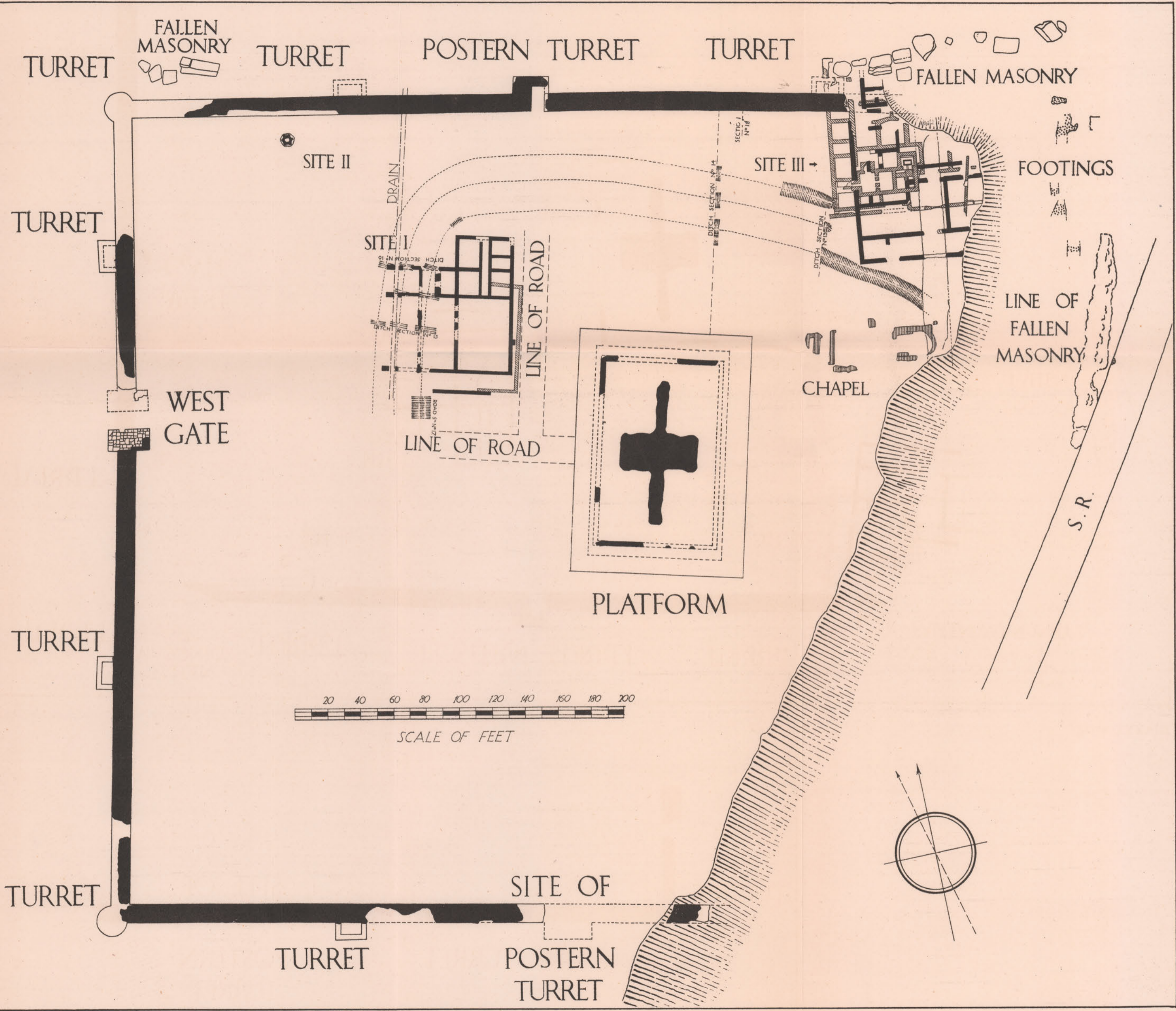

GENERAL SITE PLAN

DETAIL PLAN OF SITE III ETC.

SITE III

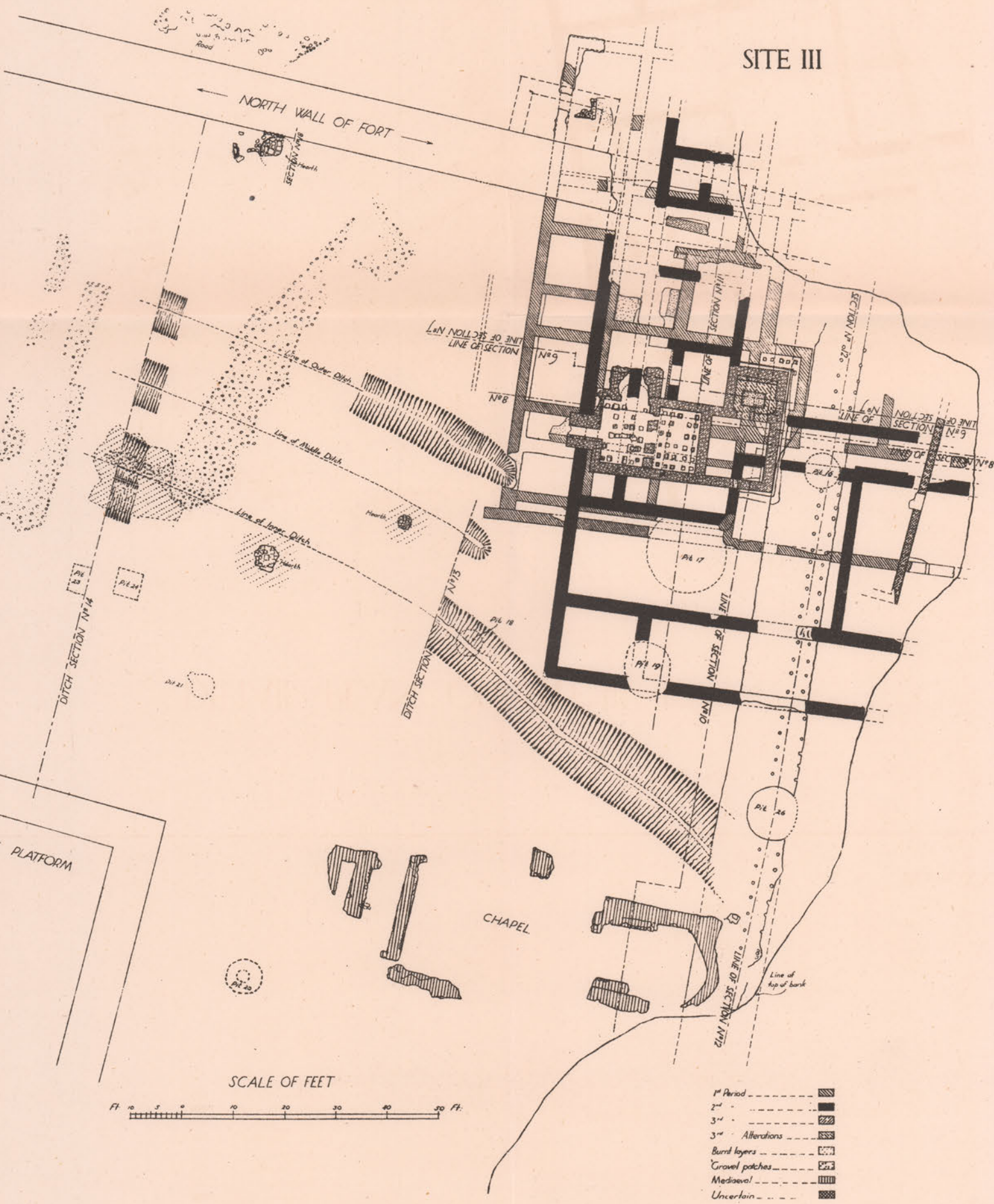
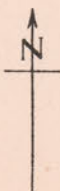

PLAN OF SITE III, ETC.

Published by the Society of Antiquaries of London, 1928

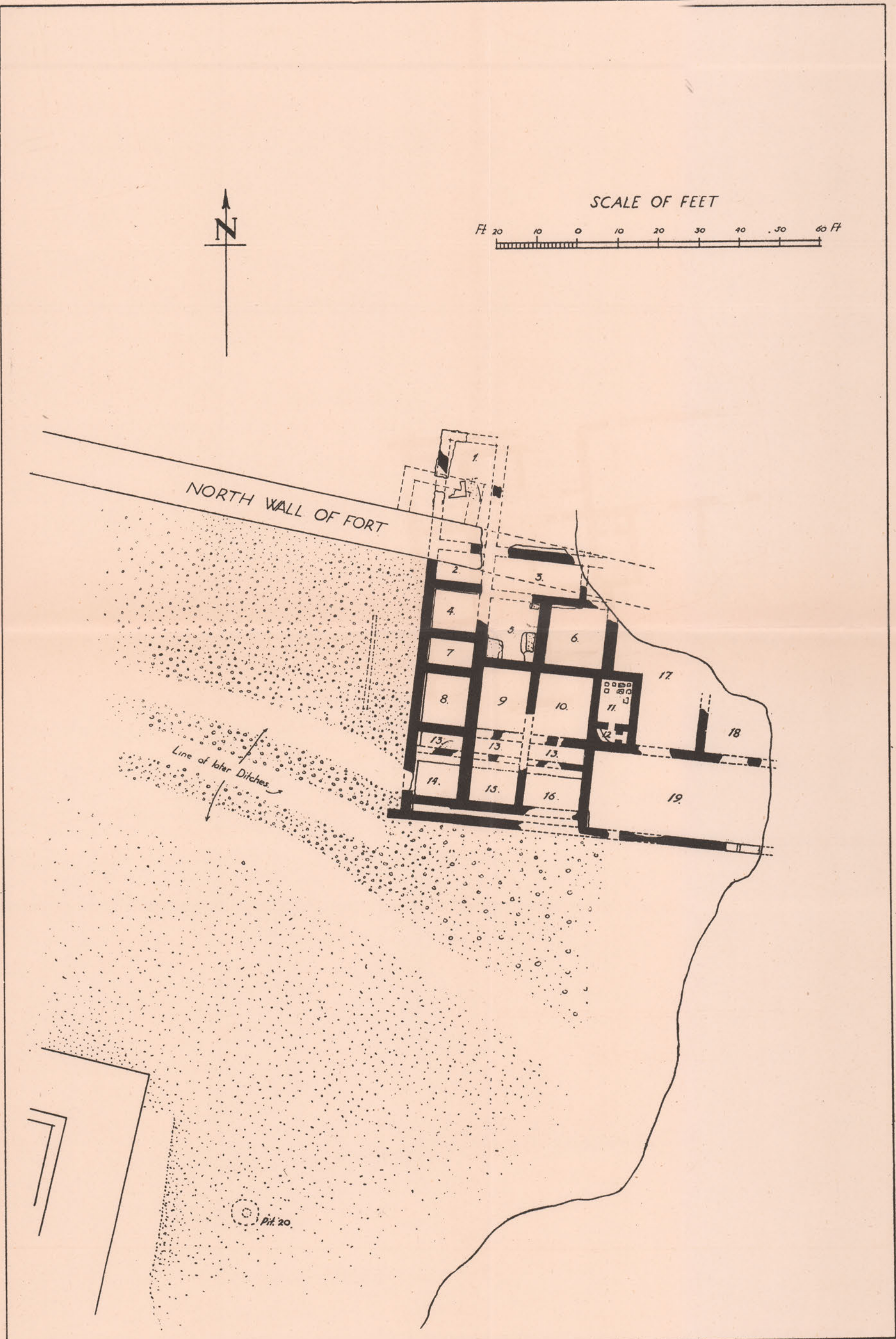

PLAN OF 1ST HOUSE, etc., SITE III

Published by the Society of Antiquaries of London, 1928

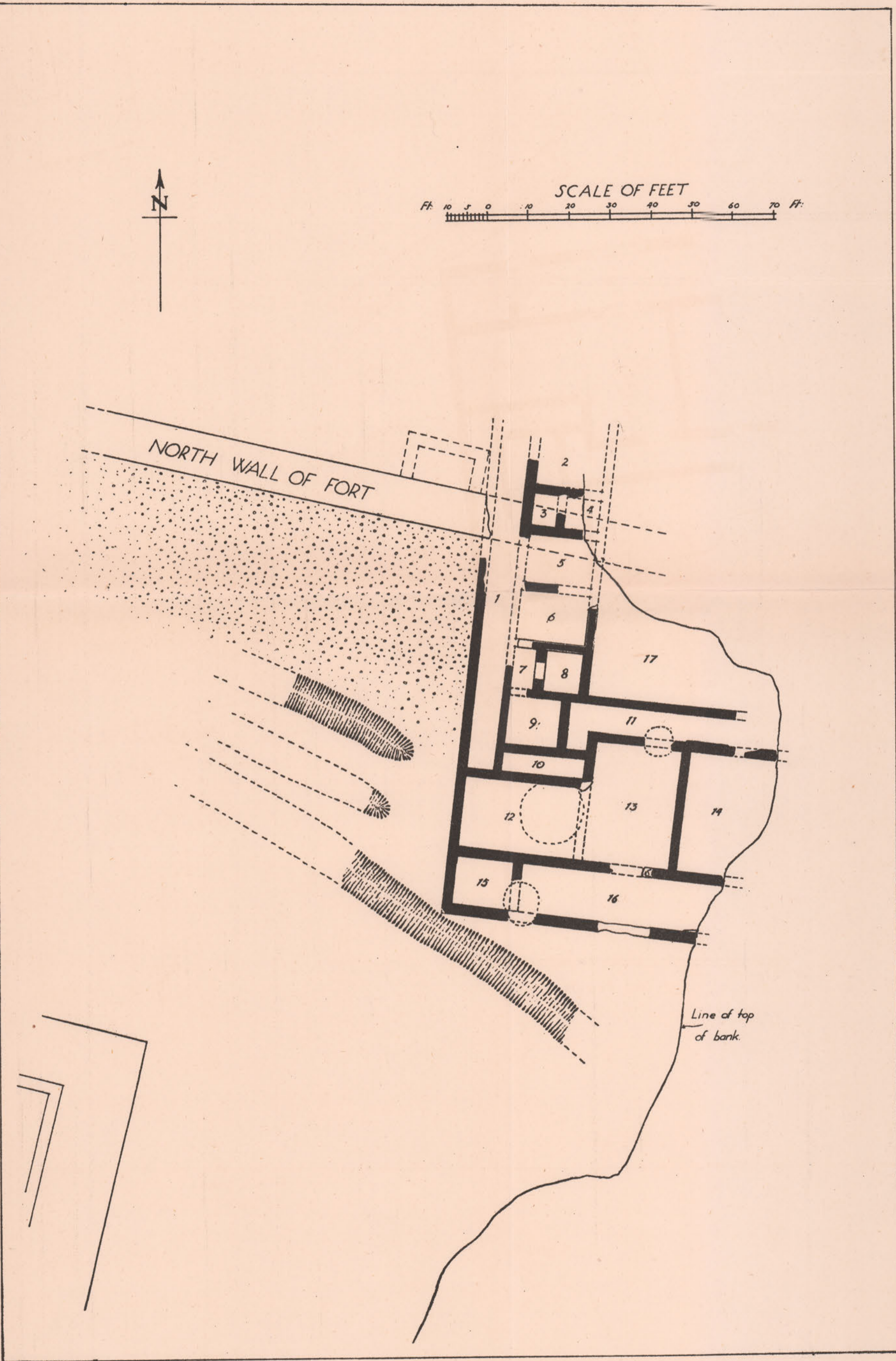

PLAN OF 2ND HOUSE, ETC., SITE III

Published by the Society of Antiquaries of London, 1928

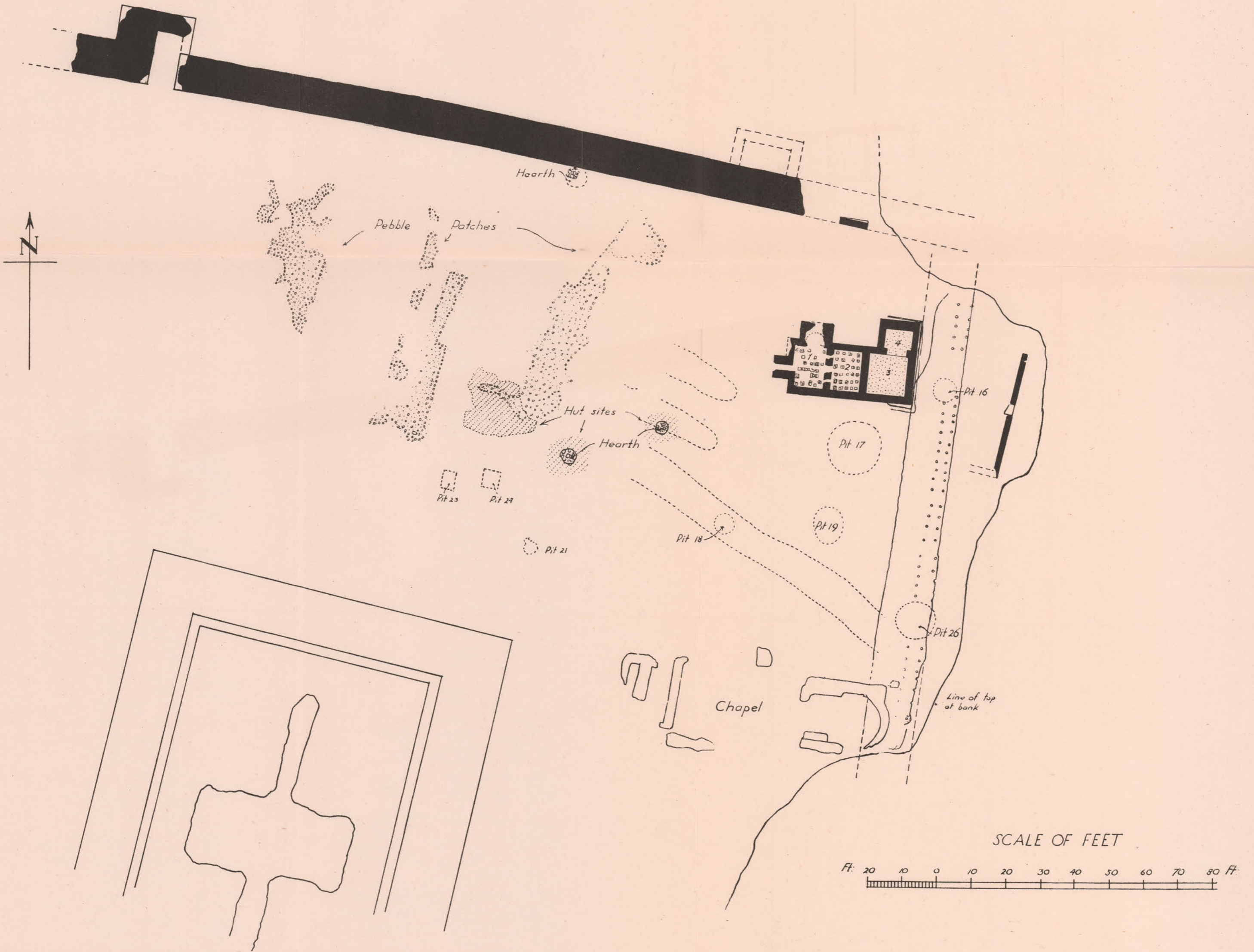

PLAN OF 3RD HOUSE, ETC., SITE III

Published by the Society of Antiquaries of London, 1928

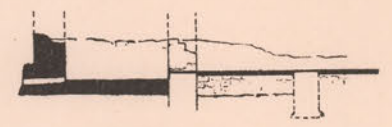

SECTION A.A

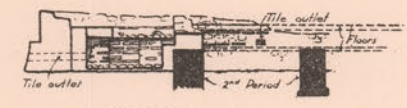

SECTION E.E

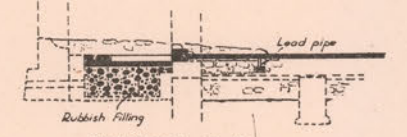

SECTION C.C

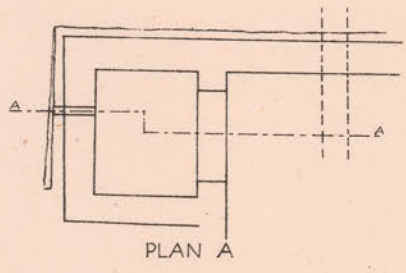

PLAN A
FIRST BUILD

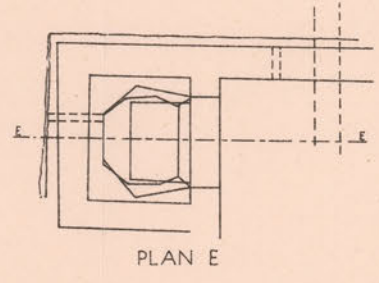

PLAN E
AS EXISTING

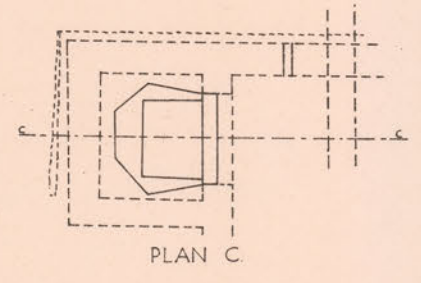

PLAN C
THIRD BUILD

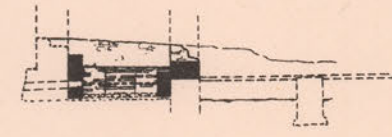

SECTION B.B

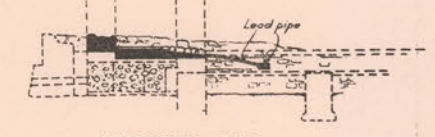

SECTION D.D

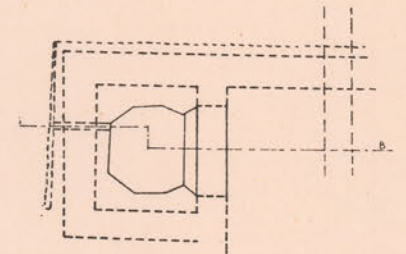

PLAN B
SECOND BUILD

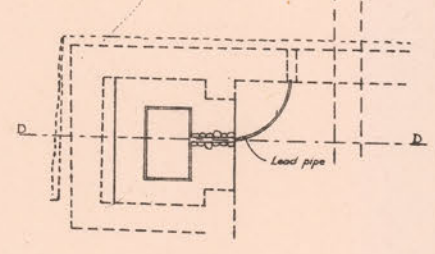

PLAN D
FOURTH BUILD

DETAIL OF
BATH BUILDING
SITE III

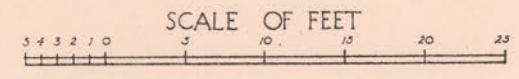

Site III: Details of bath building

RICHBOROUGH CASTLE

SECTIONS THROUGH BUILDINGS IN N E CORNER OF FORT

Key to Periods.

- 1st Period
- 2nd "
- 3rd "
- Uncertain.
- Mediaeval Chapel

Scale of Feet

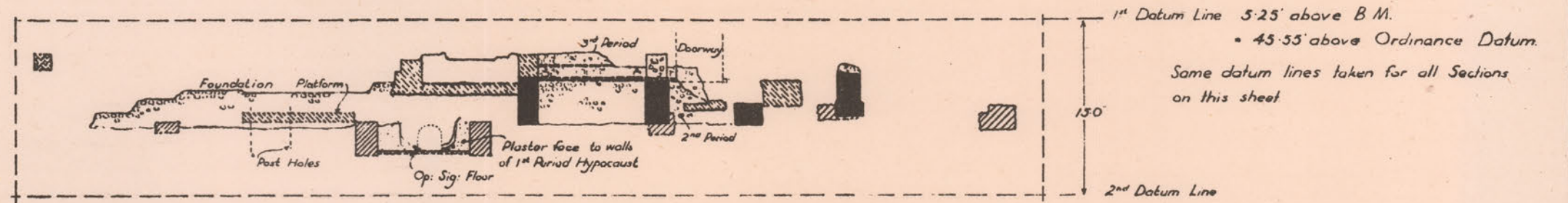
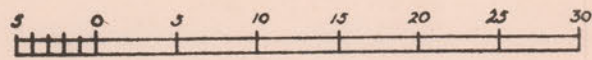

SECTION N°7 Looking South.

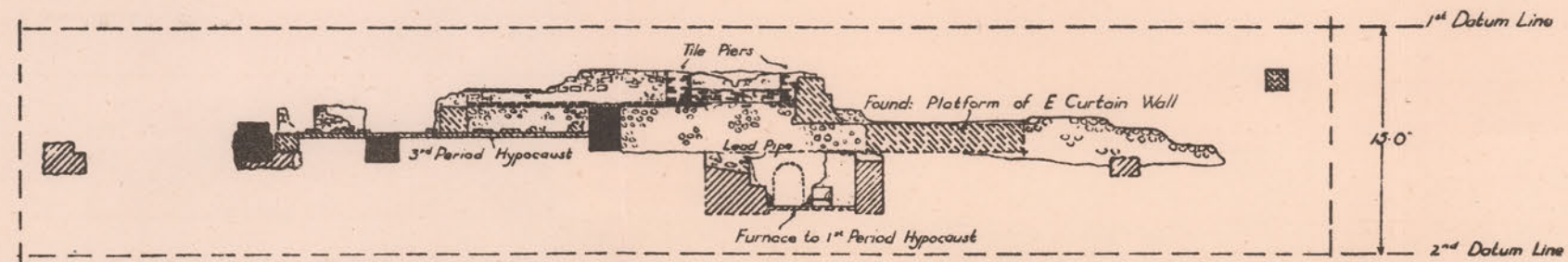

SECTION N°8 Looking North

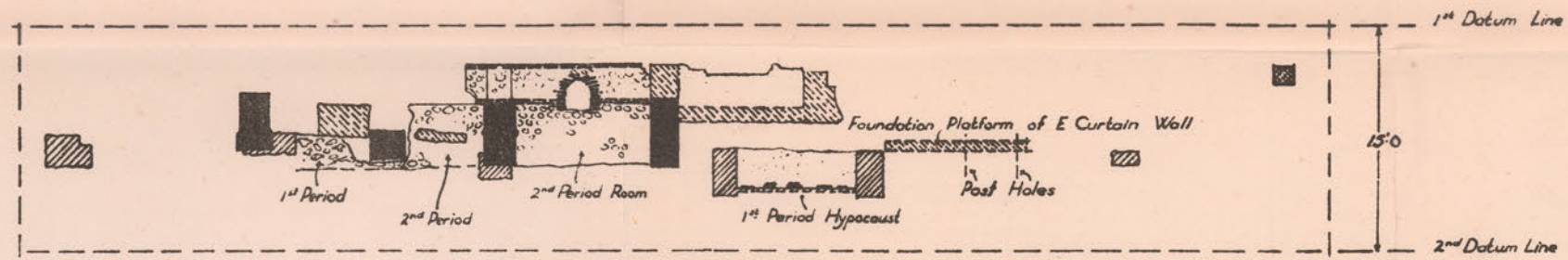

SECTION N°9 Looking North

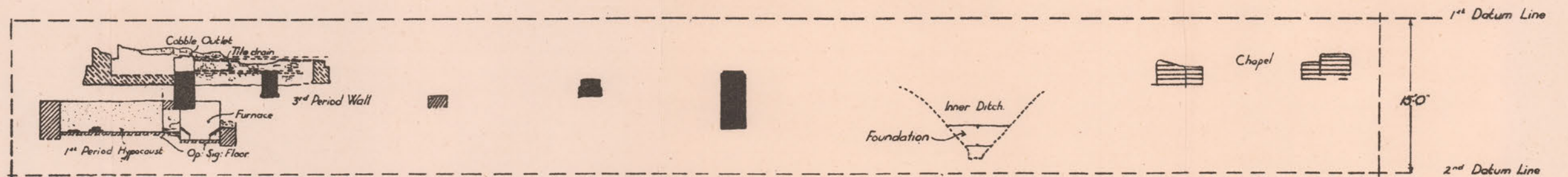

SECTION N°10 Looking East

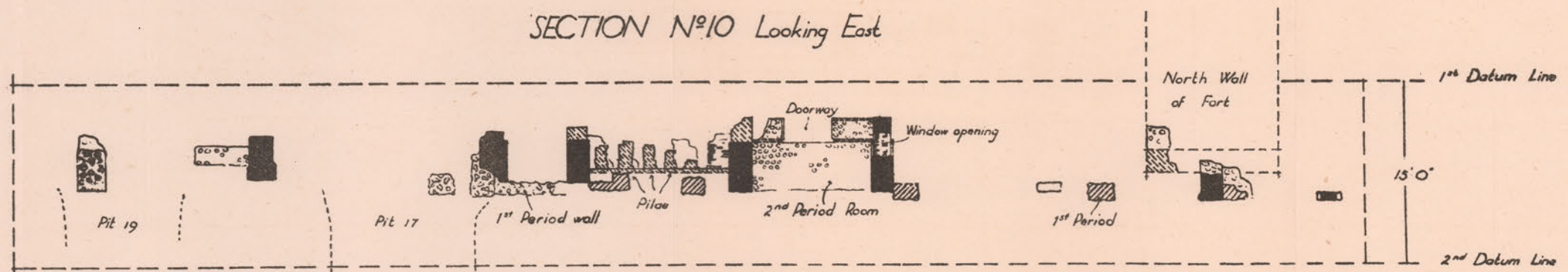

SECTION N°11 Looking West

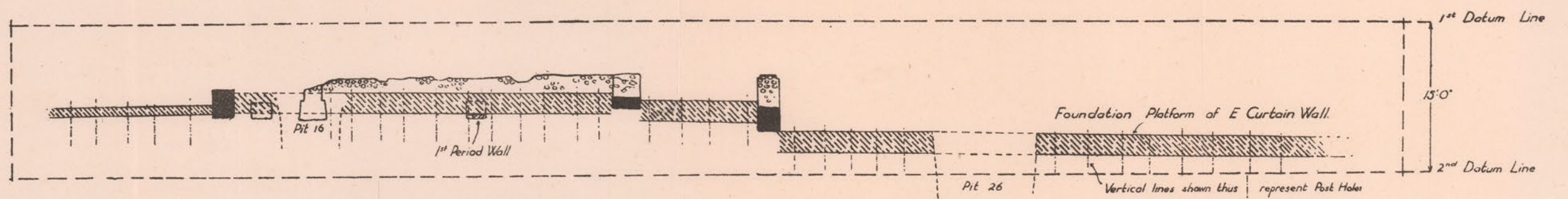

SECTION N°12 Looking East

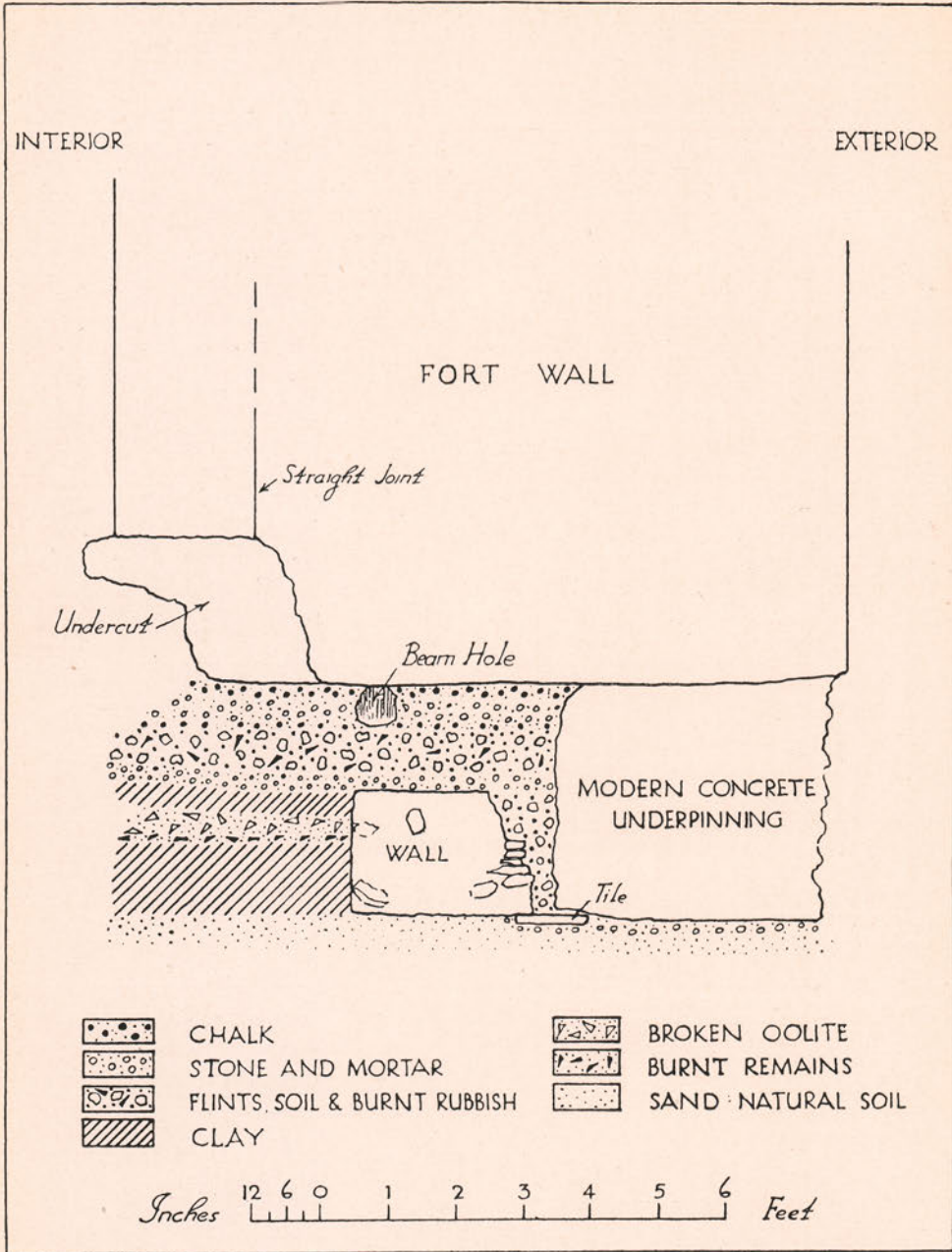

Section under E. end of N. wall of fort

KEY TO PLATE XLVI, SECTION 14

1. Samian forms 37 (A.D. 70-80), 24, and 27.
2. Samian forms 15 (2), 18, and 27.
3. Samian forms 29 (5) (60-80) and 82.
4. Samian form 18.
5. Coin of Vespasian.
6. Samian forms 29 (3) (60-80), 15 (2), and 27.
7. Coin of Vespasian, Cos. III (72-3).
8. Samian form 37 (75-90).
9. Samian form 37 (90-120).
10. Five Constantinian coins 335-40.
11. Samian forms 37 (75-100), 29 (2), 18 (3), 27.
12. Samian forms 29 (2), 18 (2).
13. Coin, barbarous, Constantinopolis.
14. Samian form 38.
15. Marble.
16. Flanged plate, 3rd or 4th century.
17. Samian form 37 (Antonine).
18. Samian form 37 (Antonine), flagon mouth with four rings (80-120), hammer head mortarium (late 2nd or 3rd century).
19. Marble (2).
20. Coin of Nero.
21. Samian forms 27, 33; mortarium (late 2nd or 3rd century).
22. Samian forms 37 (late 2nd century).
23. Mortarium (late 2nd or 3rd century).
24. Samian form 18 (2), marble I.
25. Coin, possibly Claudius I.
26. Marble.
27. Marble (2).
28. Samian form 18.
29. Samian form 18.
30. Two coins, Tetricus (268-73).
31. Samian form 37 (75-100) and part of a green-glazed vessel decorated with acorns and oak leaves (1st century).
32. Samian forms 15 and 18.
33. Samian forms 57 (75-85), 35, and 82.
34. Samian forms 29 and 18, marble I.
35. Base of a bulbous beaker (3rd or 4th century).
36. Coin of Claudius Gothicus 268-70.
37. Fragment of Rhenish ware bulbous beaker (late 2nd or 3rd century) and piece of marbled ware bowl type 170 of this Report.

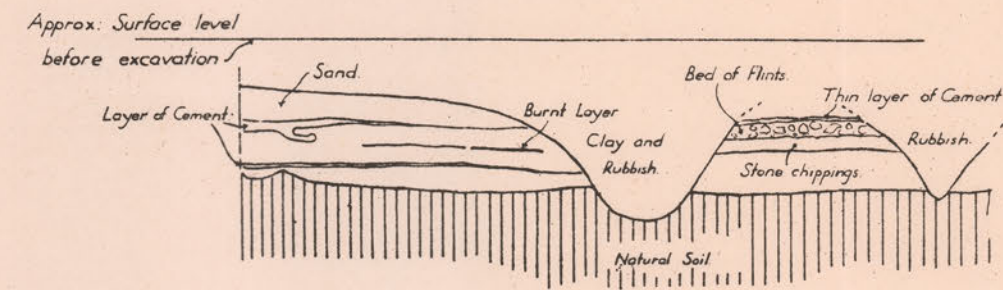

SECTION N°13

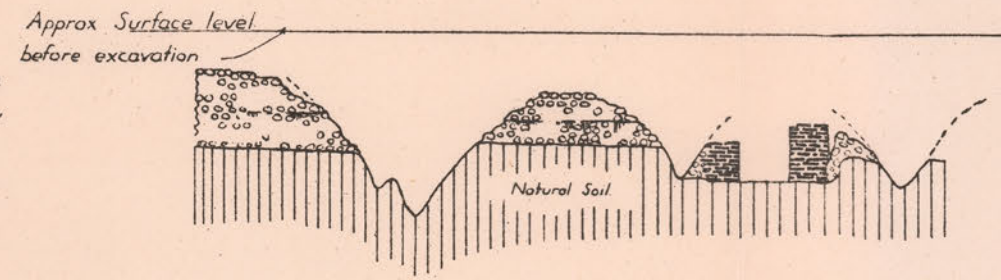

SECTION N°16

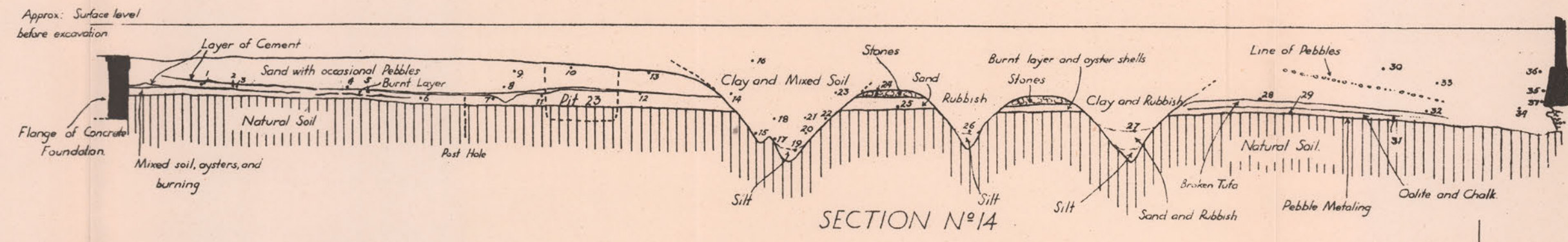

SECTION N°14

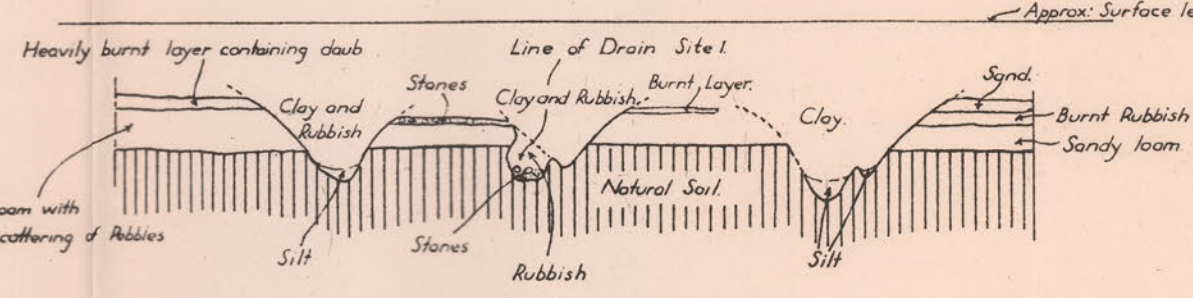

SECTION N°15

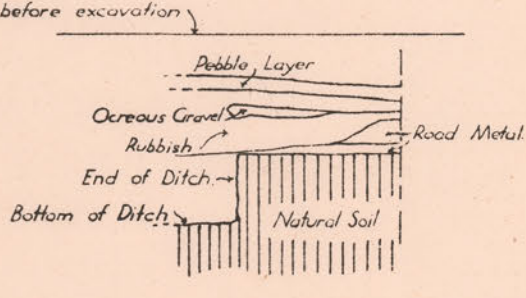
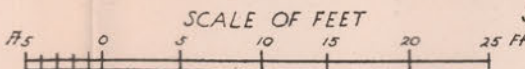

SECTION N°17

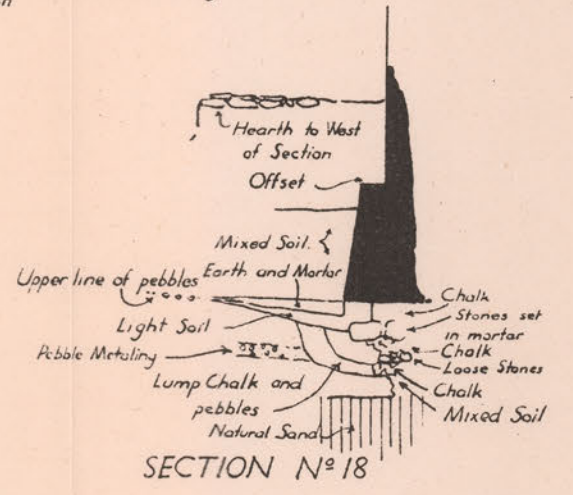

SECTION N°18

DITCH SECTIONS, ETC. : No. 18 IS DOUBLE SCALE

Published by the Society of Antiquaries of London, 1928

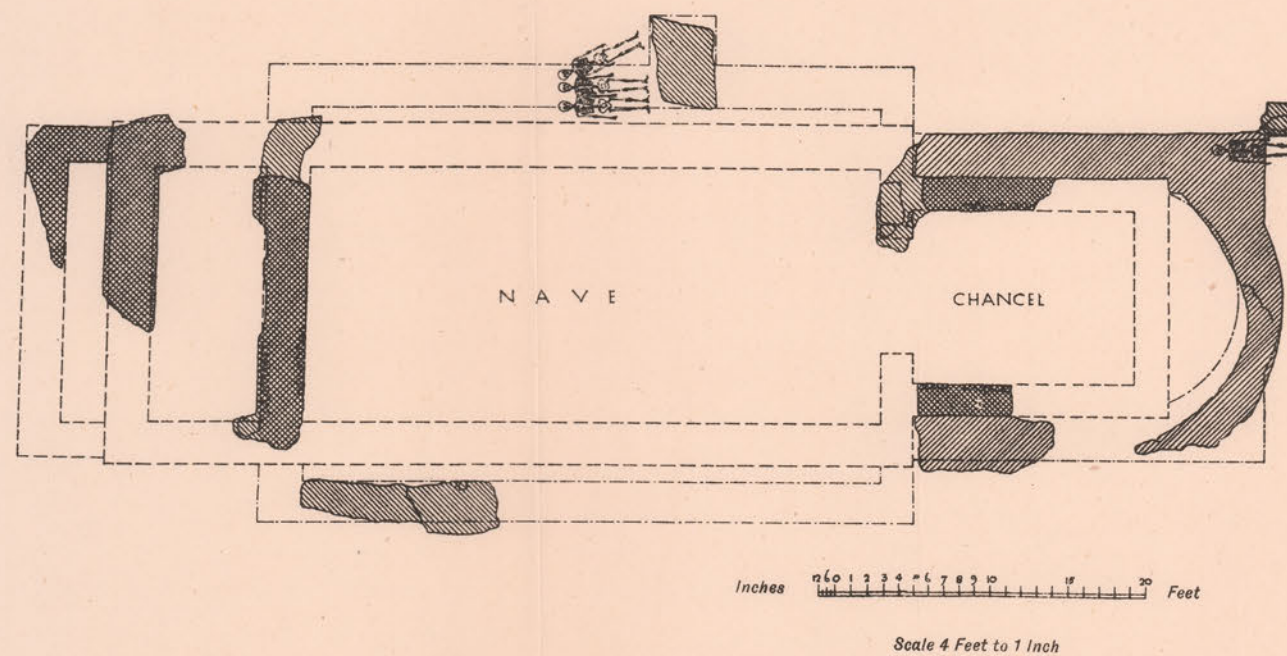

Plan of Chapel

Published by the Society of Antiquaries of London, 1928